

A2F



Axial Piston-Bent Axis Design
Fixed Displacement Pump/Motor



斜轴式轴向柱塞 定量泵/马达

技术样本



北京华德液压工业集团有限责任公司
BEIJING HUADE HYDRAULIC INDUSTRIAL GROUP CO.,LTD.

☎ 销售服务热线 **400-000-6987**

本公司通过:

- 【ISO9001质量管理体系认证】
- 【ISO14001环境管理体系认证】
- 【OH SAS18001职业健康安全管理体系认证】
- 【CE认证】

编制: 华德液压技术中心



北京华德液压工业集团有限责任公司
BEIJING HUADE HYDRAULIC INDUSTRIAL GROUP CO., LTD.

2013年9月编制

目 录 CONTENTS

1

A2F 定量泵/马达

1

Fixed Displacement Pump/Motor A2F

2

A2FE 内藏式定量马达

7

Internal Installation Fixed Displacement Motor A2FE

3

A2FE 内藏式定量马达（6系列）

11

Fixed Displacement Plug-In Motor A2FE



注意事项

1. 为了保证无故障的高效工作，在设计系统期间应根据工况仔细选择液压系统的液压油，所有矿物油基液压油均在某种程度上适用于轴向柱塞元件，它们的应用时基本划分取决于上述的水、粘度与温度关系，并考虑氧化和腐蚀保护、材料相容性、空气和水分离特性。

2. 为了保证设备有长的使用寿命，必须进行良好而可靠的过滤。油液中的硬颗粒污染不得超过以下等级：

等级9——按NAS1638

等级6——按SAE

等级18 / 15——按ISO / DIS 4406

在油液温度很高时，最低清洁度为：

等级8——按NAS1638

等级5——按SAE

等级17 / 14——按ISO / DIS 4406

3. 为了正确选择液压油，必须知道与环境温度有关的工作温度；在闭式回路中这是回路温度，在开式回路中这是油箱温度。

4. 注意：漏油(壳体泄油)温度受压力和转速的影响，总是高于回路温度，然而要求回路中任何点温度不得超过90℃。

如果由于极端的工作参数或较高的环境温度，而不能维持上述条件，订货时请询问我公司。

5. 泵的进油口压力(绝对压力)处须 $\geq 0.08\text{MPa}$ ，及泄油压力(壳体内允许的最高压力)为 0.2MPa (绝对压力)，壳体内压力值必须等于或高于作用在轴密封上的外部压力值。

6. 安装位置：一般要求液压泵 / 马达安装位置、壳体上边缘低于油箱最低液面。若安装需在油面以上，请在订货时提出。

《样本》所述技术资料，仅供参考。若有特殊要求请与我集团公司技术部门咨询，若有更改，恕不通知。

The technical information in the catalog is for your reference. Please consult our technical Dept. , if you have any special requirements.

NOTES

1. In order to guarantee trouble-free and efficient operation, the hydraulic fluid in a hydrostatic system should be selected carefully according to the actual working conditions during the design of the system. All mineral oil based fluids are suitable to a greater or lesser degree for application in axial piston units. Their basic classification of application results from what has already been said due to the water, viscosity and temperature relationships, with consideration of oxidization and corrosion protection, material compatibility, air and water separation characteristics.

2. In order to guarantee a long service life for the installation, good and reliable filtration is necessary. The hard particle contamination of fluid may not exceed a level determined by:

Class 9 to NAS 1638

Class 6 to SAE

Class 18/15 to ISO/DIS 4406

When the fluid temperature is too high, the required minimum degree of cleanliness is:

Class 8 to NAS 1638

Class 5 to SAE

Class 17/14 to ISO/DIS 4406

3. In order to select the correct fluid, it is necessary to know the operating temperature in the circuit in relation to the ambient temperature—in an open circuit and the tank temperature.

4. Important: The leakage oil(case drain oil)temperature is influenced by pressure and pump speed and is always higher than the circuit temperature, However, at no point in the circuit may the temperature exceed 90℃.

If it is not possible to comply with the above conditions because of extreme operating parameters or high ambient temperatures, please consult us.

5. The minimum pressure at the suction port of the pump $\geq 0.08\text{Mpa}$ (absolute pressure), and the drain pressure(max. permissible casing pressure)is 0.2MPa (absolute pressure). The pressure in the housing must be the same or greater than the external pressure on the shaft seal.

6. Installation position: in general, the upper point on the pump/motor housing must be below the minimum oil level of the tank, If you would like to install it above the minimum oil level, please indicate when order.

北京华德液压工业
集团有限责任公司
BEIJING HUADE HYDRAULIC
INDUSTRIAL GROUP CO.,LTD.

A2F定量泵 / 马达 Fixed Displacement Pump/Motor A2F

RC90100/12.2004

用于开式和闭式回路
For open and closed circuits

斜轴式轴向柱塞结构
axial tapered piston, bent axis design

规格 Size 10-500

高压范围 Peak pressure 至 up to 40MPa

替代: Replace RC90100/09.2003

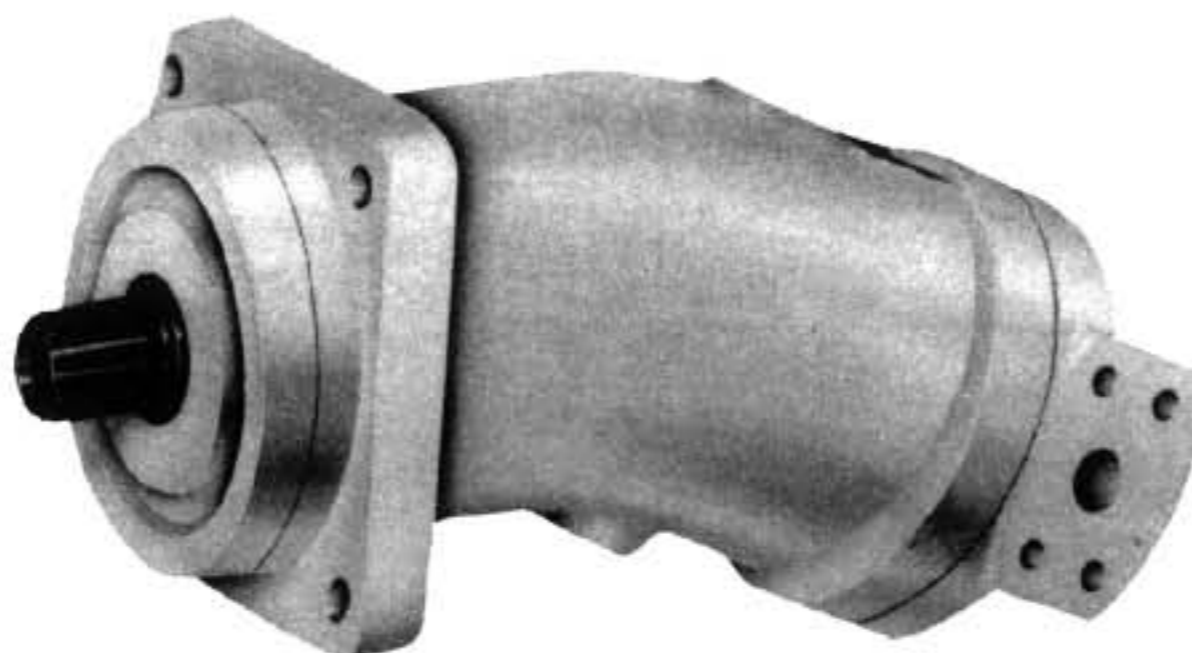

说明:

- 弯轴结构的轴向柱塞元件，具有固定排量，在开式或闭式回路中用作静液传动的泵或马达。
- 当作为泵工作时，流量与驱动转速和排量成正比。
- 当作为马达工作时，输出转速与流量成正比而与排量成反比。输出扭矩随高压侧与低压侧之间的压差而加大。

特点:

- 带有久经考验的球面配流盘的高性能旋转组件有自动对中、圆周速度低、效率高的优点。
- 耐用的球轴承和滚子轴承促进长工作寿命。
- 驱动轴能承受径向载荷。
- ISO安装法兰，从规格55起定量泵/马达和变量马达一致。
- 可使用抗燃液压油。
- 噪声低。

剖视图:

结构1-4, 规格10-160

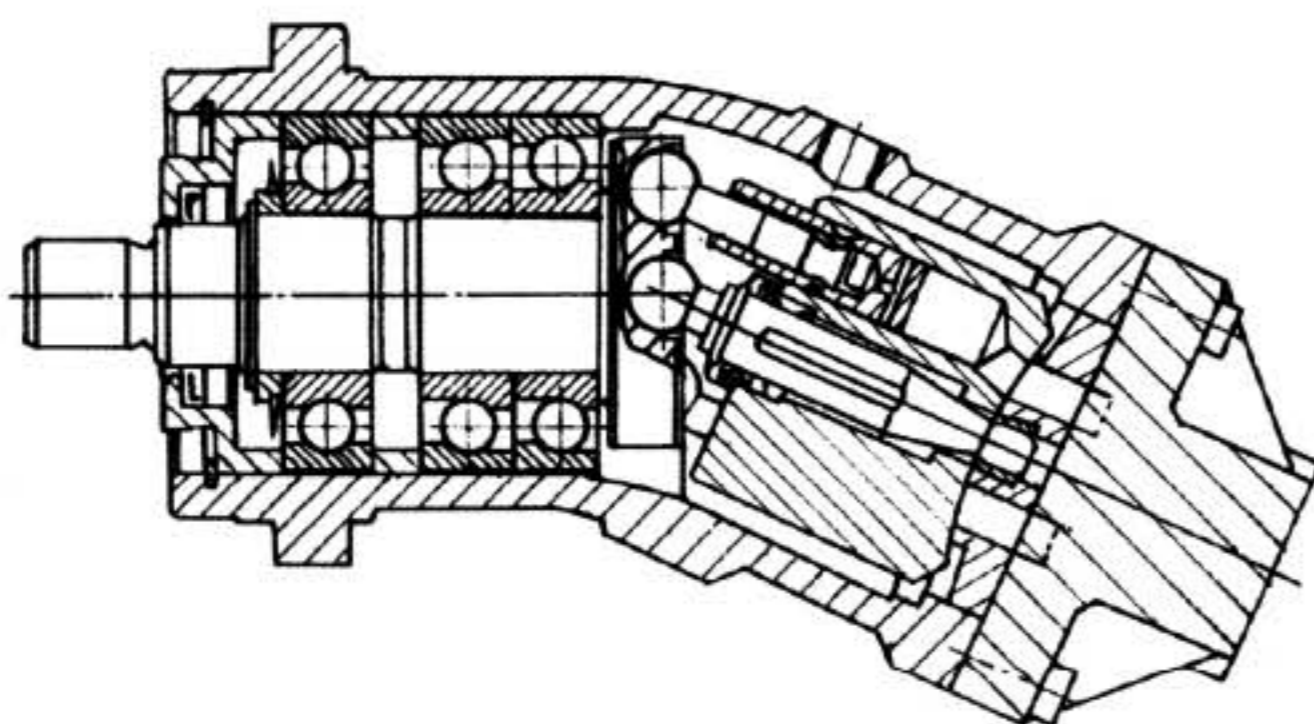

Description:

Axial piston unit of bent axis design with fixed displacement, for use as either pump or motor in hydrostatic drivers, in open or closed circuit.

If operated as a pump, the flow is proportional to the drive speed and displacement.

If operated as a motor, the output speed is proportional to the swept volume and inversely proportional to displacement. The output torque increases with the pressure drop between the high and low pressure sides.

Special Features:

High performance rotary group with well-proven spherical control area with the advantages: self-centering low peripheral speed, high efficiency.

Robust rolling bearings endure long service life.

Drive shaft capable of adopting radial loading.

ISO mounting flange, uniform for fixed displacement Pumps/motors and variable motors from size 55

May be used in conjunction with fire-resistant fluids.

Low noises generation.

Section:

Series 5, Sizes 200-500

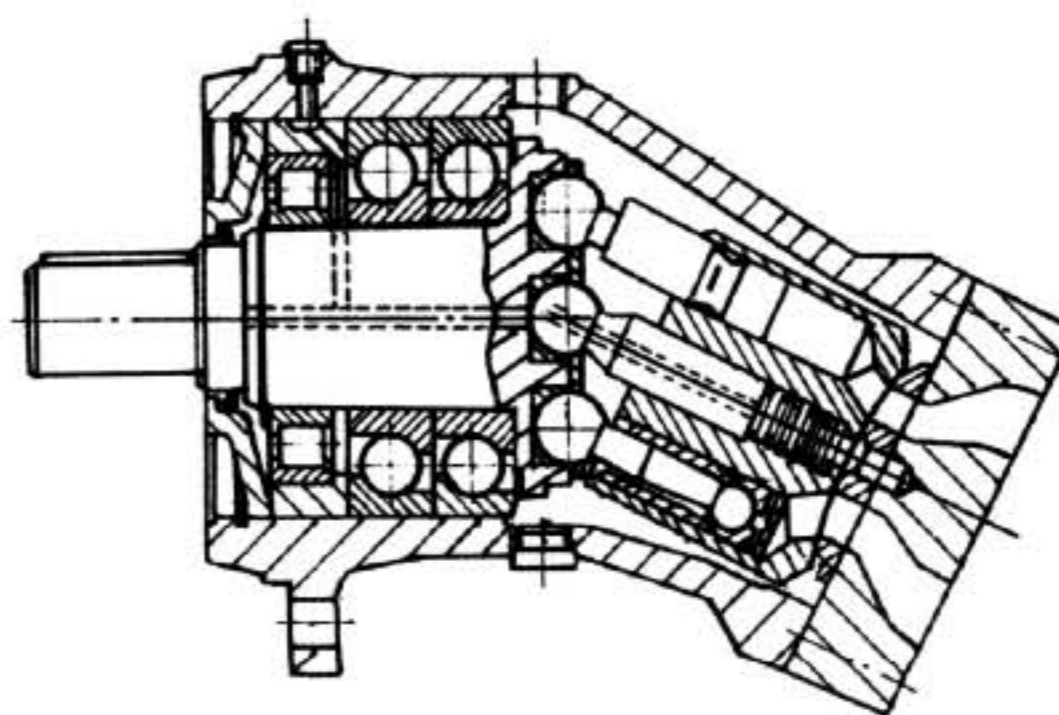

A2F定量泵 / 马达 Fixed Displacement Pump / Motor A2F

型号说明 Type Code

A2F 55 R 2 P 1

泵 / 马达型号 Pump/Motor Type

定量泵 / 马达 **A2F**
Fixed displacement pump/motor

规格 Size

(9.4)	10
(11.6)	12
(22.7)	23
(28.1)	28
(44.3)	45
(54.8)	55
(63.0)	63
(80.0)	80
(107)	107
(125)	125
(160)	160
(200)	200
(250)	250
(355)	355
(500)	500

(排量 displacement ml/r)

后盖 Port Plate

见下 below	后盖 Port Plate	1
	后盖 Port Plate	2
	后盖 Port Plate	3
	后盖 Port Plate	4

轴伸 Shaft End

平键	keyed shaft GB1096-79	P
花键	splines shaft DIN 5480	Z
花键	splines shaft GB 3478.1-83	S

结构形式 Series

见下 see below	结构 Series	1
	结构 Series	2
	结构 Series	3
	结构 Series	4
	结构 Series	5

旋转方向 Direction of Rotation

从轴端看	viewed on drive shaft	
顺时针	clockwise	R
逆时针	anti-clockwise	L
双向	alternating	W

订货示例:



A2F.55.R.2.P.1
A2F定量马达
规格55, 顺时针旋转, 2结构, 平键
1号后盖

Ordering Example:

A2F.55.R.2.P.1
Fixed displacement motor A2F
size55, clockwise rotation, series 2,
keyed shan, port plate 1

(不适用于开式回路中的泵) (not for pumps in open circuit)

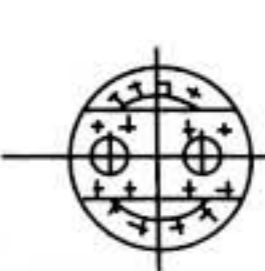
结构型式 Series		4		2/3		1/2	1/2	2		1/2	2		5			
规格	Size	10	12	23	28	45	55	63	80	107	125	160	200	250	355	500
后盖	port plate 1	1	●	●	●	●	●	●	●	●	●	●	●	●	●	●
		2			●	●	●	●	●	●	●	●	●	●	●	●
		3				●	●	●	●	●	●	●				
		4	●	●	●	●										

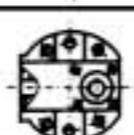
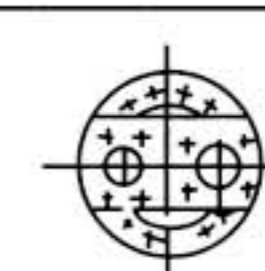
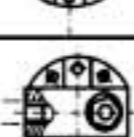
后盖 port plate I		10-160				200-500				
规格	Size									
闭式回路泵工况 和马达工况 pump operation in closed circuit and motor operation	1 螺纹 metric threads					1 法兰 Flange				
	2 SAE 法兰 Flange									
开式回路泵工况 pump operation in open circuit	3 法兰 Flange					2 法兰 Flange				
	4 螺纹 metric threads									

A2F定量泵 / 马达 Fixed Displacement Pump / Motor A2F

技术数据 Technical Data

进口工作压力 Inlet Operating Pressure

泵 Pump

S、A或B口最低压力

Minimum pressure at ports A or B

$P_{abs} \quad 0.08\text{MPa}$

在闭式回路中，补油压力必须在0.2至0.6MPa之间，视泵的转速和液压油的粘度而定。

in closed circuits, the feed pressure must be between 0.2MPa and 0.6MPa, depending on pump speed and viscosity hydraulic fluid.

马达 Motor

A或B口的压力 Pressure at port A or B

额定压力 Nominal pressure $P_N = 35\text{MPa}$

最高压力 Peak pressure $P_{max} = 40\text{MPa}$

A口和B口压力之和不得超过70MPa(每侧压力最高40MPa)

The sum of the pressures at ports A and B must not exceed 70MPa(individual pressure on either side max. 40MPa)

出口工作压力 Outlet Operating Pressure

泵 Pump

额定压力 Nominal pressure $P_N = 35\text{MPa}$

最高压力 Peak pressure $P_{max} = 40\text{MPa}$

壳体压力 Case pressure

允许最高壳体压力(油口T)

Maximum permissible case pressure(at port T)

$P_{abs} \quad 0.2\text{MPa}$

油温范围 Oil Temperature Range

$t_{min} \quad -25^\circ\text{C}$

$t_{max} \quad +80^\circ\text{C}$

粘度范围 Viscosity Range

$V_{min} \quad (\text{短期}) \text{ (for short periods)} 10\text{mm}^2/\text{s}$

$V_{max} \quad (\text{短期}) \text{ (for short periods)} 1000\text{mm}^2/\text{s}$

最佳工作粘度 Optimum Operating Viscosity

$V_{opt} \quad 16\text{--}36\text{mm}^2/\text{s}$

规格计算 Calculation of Size

泵 pump

流量 Flow $Q = \frac{V_g \cdot n \cdot \eta_v}{1000}$ [L/min]

扭矩 Torque $M = \frac{1.59 \cdot V_g \cdot \Delta p}{10 \cdot \eta_{mh}}$ [Nm]

功率 Power $P = \frac{M \cdot n}{9549} = \frac{Q \cdot \Delta p}{60 \cdot \eta_t}$ [kW]

马达 Motor

流量 Flow $Q = \frac{V_g \cdot n}{1000 \eta_v}$ [L/min]

扭矩 Torque $M = \frac{1.59 \cdot V_g \cdot \Delta p \cdot \eta_{mh}}{10}$ [Nm]

功率 Power $P = \frac{M \cdot n}{9549} = \frac{Q \cdot \Delta p \cdot \eta_t}{60}$ [kW]

转速 Speed $n = \frac{Q \cdot 1000 \cdot \eta_v}{V_g}$ [r/min]

$V_g =$ 排量 geom.displacement(ml / r)

$\Delta p =$ 压差 pressure differential(MPa)

$n =$ 转速 speed(rpm)

$\eta_v =$ 容积效率 volumetric efficiency

$\eta_{mh} =$ 机械效率 mech—hydr. efficiency

$\eta_t =$ 总效率 overall efficiency

$[\eta_t = \eta_v \cdot \eta_{mh}]$

油液选择 Fluid Recommendations

工作温度范围 推荐粘度等级 符合 DIN51519 ISO(VG)

Operating temperature range	Recommended viscosity grade to DIN 51 519 ISO(VG)	在at	
30—40°C	VG22 Δ 22mm ² / s	在at	40°C
40—50°C	VG32 Δ 32mm ² / s	在at	40°C
50—60°C	VG46 Δ 46mm ² / s	在at	40°C
60—70°C	VG68 Δ 68mm ² / s	在at	40°C
70—80°C	VG100 Δ 100mm ² / s	在at	40°C

液压油的过滤

推荐过滤精度为10 μm ，25—40 μm 的较粗的过滤是可以使用，但是10 μm 过滤可以延长使用寿命(降低磨损)。

Filtration of Hydraulic Fluid

Recommended filtration: 10gm Coarser filtration of 25—40 μm , is available, but with filtration of 10 μm longer service life is obtained(reduced wearing).

转速范围

最低转速 n_{min} 没有限制，如果要求高度旋转均匀性，则 n_{min} 不得低于50rpm。关于最高转速 n_{max} 请见第4页的表。

Speed Range

No limitation on minimum speed n_{min} . If high uniformity of rotation is required, n_{min} should not be less than 50 rpm. See table on page 4 for maximum speed n_{max} .

安装位置

任选。壳体必须始终充满油液

Mounting Position

Optional. The housing must always be filled with oil.

A2F定量泵 / 马达 Fixed Displacement Pump / Motor A2F

技术参数表 理论值·未考虑 η_{mh} 和 η_v , 数值经过圆整

Technical Data theoretical values, without considering η_{mh} and η_v values rounded off

规格 Size				10	12	23	28	45	55	63	80	107	125	160	200	250	355	500				
排量 Displacement	V_g	ml/r		9.4	11.6	22.7	28.1	44.3	54.8	63	80	107	125	160	200	250	355	500				
最高转速	闭式回路	close circuit	n_{max}	r/min	7500	6000	5600	4750	3750	3750	3350	3350	3000	3150	2650	2500	2500	2240	2000			
Max. speed	开式回路	open circuit	在 0.09MPa 下 ¹⁾	$n_{0.09}$	r/min	4700	3750	3750	2800	2360	2360	2550	2120	1900	2120	1650	1700	1400	1250	1120		
			在 0.1MPa 下 ¹⁾	$n_{0.1}$	r/min	5000	4000	4000	3000	2500	2500	2700	2240	2000	2240	1750	1800	1500	1320	1200		
			在 0.15MPa 下 ¹⁾	$n_{0.15}$	r/min	6000	4900	4900	3600	3000	3000	3300	2750	2450	2750	2100	2180	1850	1650	1500		
最大流量	闭式回路	close circuit	Q_{max}	l/min	71	70	127	133	166	206	252	268	321	394	424	500	625	795	1000			
Max. flow	开式回路	open circuit	在 $n_{0.09}$ 下 ²⁾	$Q_{0.09}$	l/min	43	42	83	76	122	125	156	164	197	257	256	330	340	430	543		
			在 $n_{0.1}$ 下 ²⁾	$Q_{0.1}$	l/min	46	45	88	82	129	133	165	174	208	272	272	349	364	455	582		
			在 $n_{0.15}$ 下 ²⁾	$Q_{0.15}$	l/min	55	55	108	98	157	160	202	213	254	334	326	423	449	568	728		
最大功率	闭式回路	close circuit	P_{max}	KW	41	41	74	78	97	120	147	156	187	230	247	292	365	464	583			
Max. power	开式回路	open circuit	在 $Q_{0.09}$ 下	$P_{0.09}$	KW	26	26	50	46	71	75	93	99	119	154	154	198	204	259	326		
			在 $Q_{0.1}$ 下	$P_{0.1}$	KW	27	27	53	49	75	80	99	105	125	163	163	210	218	273	350		
			在 $Q_{0.15}$ 下	$P_{0.15}$	KW	33	33	65	59	92	96	121	128	153	200	196	254	270	342	437		
电机转速	流量	闭式 close	Q	l/min	13.6	16.8	32.9	40.7	64.2	79.5	91.3	116	155	181.2	232							
Electric motor flow	开式 2)open	Q_0	l/min	13.2	16.3	31.9	39.5	62.3	77.1	88.6	112.5	150.5	175.8	225								
speed	功率 power		P	KW	8	10	19	24	38	46	53	68	91	106	135							
n=1450rpm ($\Delta p=35MPa$)																						
扭矩 Torque	$\Delta p=10MPa$	M	Nm	15	18.5	36	44.6	70.4	87	100	127.5	169.7	198	254	318.5	397.9	565	795.7				
				M_{max}	Nm	52.5	64.5	126	156	247	305	350	446	594	693	889	1114	1393	1978	2785		
近似重量	Weight(approx.)	kg		5	5	12	12	23	23	33	33	44	63	63	88	88	138	185				

1) 这些数值适用于吸油管S有绝对压力并用矿物油工作时

These values are valid provided there is an absolute pressure at suction inlet S and when operated on mineral oil.

诺模图 Nomograph

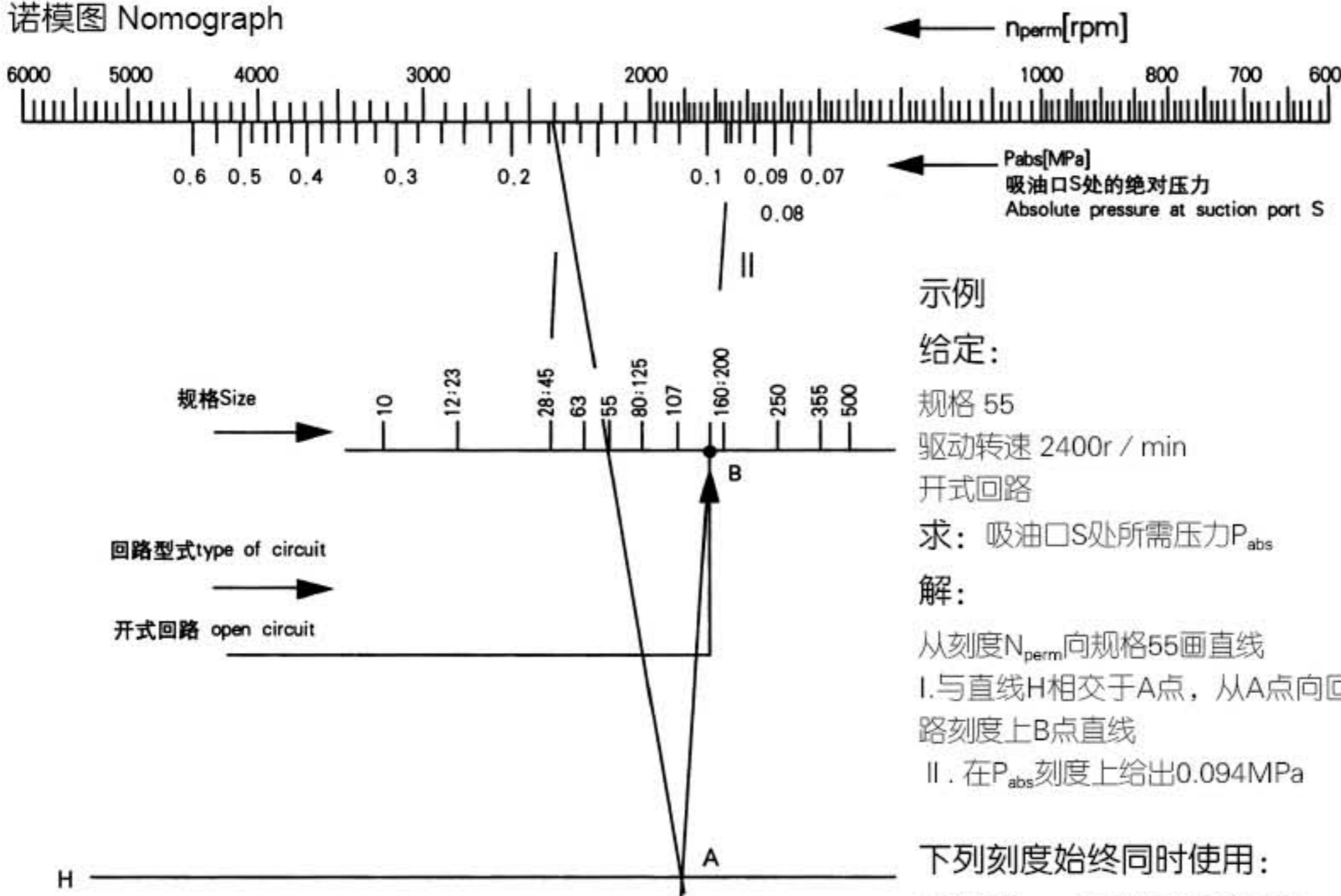

允许转速 N_{perm} 可由诺模图确定。在马达工况, 闭式回路或补油工况的允许转速也适用于开式回路。

The permissible speed N_{perm} can be determined from the nomograph. In motor operation the permissible speeds for closed circuit and feed operation are also valid for open circuit.

下列刻度始终同时使用:

1. 刻度 P_{abs} 、回路形式和直线 H
2. 直线 H、规格刻度和 N_{perm}

当进口压力 $P_{abs} > 0.1MPa$ 时开式回路(自吸工况)的允许转速可以提高, 但当 $P_{abs} < 0.1MPa$ 时必须降低。

Example

Given: Size. 55
Drive speed 2400r/min
Open circuit
Required:
Required pressure P_{abs} at suction port
Solution:
Line I on scale N_{perm} to size 55 meets line H at point A.
Line II from point A to point B on circuit scale gives 0.094MPa on scale P_{abs} .
The following are always used together: 1. Scales P_{abs} , type of circuit and line H.
2. Line H, size scale and n_{perm}

The permissible speed in open circuit (self-priming operation) may be increased when inlet pressure $P_{abs} > 0.1MPa$ but must be reduced when $P_{abs} < 0.1MPa$

A2F定量泵 / 马达 Fixed Displacement Pump / Motor A2F

外形尺寸 Unit Dimensions
规格 Size 10~160

后盖 Port Plates

结构2
Series
ISO法兰 flange

结构1
Series
结构3
Series
结构4
Series

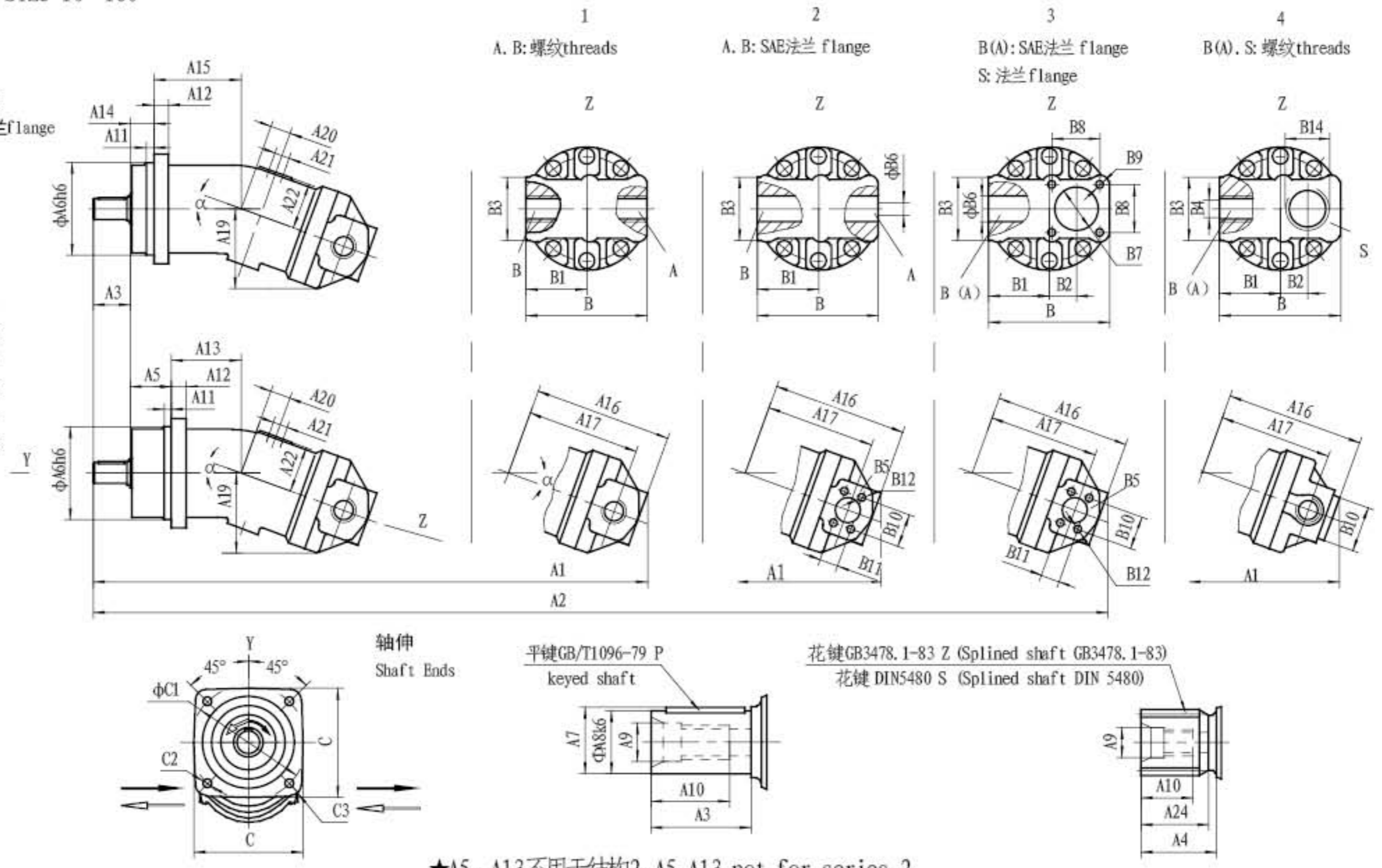

★A5, A13不用于结构2. A5, A13 not for series 2
A14, A15不用于结构1. A14, A15 not for series 1

规格 Size	结构形式	后盖型式	A1		A2																	
α20° α25°	Series	Port Plates	α20°	α25°	α20°	α25°	A3	A4	A5	A6	A7	A8	A9	A10	A11	A12	A13	A14	A15	A16		
10 12	4	1, 4	235	232	-	-	40	34	40	80	22.5	20	M6	16	8	12.5	42	-	-	112		
23 28	3, 2	1, 4	296	293	-	-	50	43	50	100	27.9	25	M8	19	8	16	50	25	75	145		
45 55	1.2	1, 2, 3	384	381	378	376	60	35	63	125	32.9	30	M12	28	10	20	77	32	108	183		
63 80	2	1, 2, 3	452	450	447	444	70	40	-	140	38	35	M12	28	10	23	-	32	137	213		
87 107	2, 1	1, 2, 3	480	476	473	468	80	45	80	160	43.1	40	M12	28	10	25	90	40	130	230		
125 160	2	1, 2, 3	552	547	547	540	90	50	-	180	48.5	45	M16	36	10	28	-	40	156	262		

规格 Size	A19		深																
α20° α25°	A17	A18	α20°	α25°	A20	A21	A22	A23	A24	B	B1	B2	B3	B4	deep	B5(SAE 法兰)			
α20° α25°	deep	B10	B11	B12	deep	B13	B14	deep	B15	C	C1	C2	C3			Flange	B6	B7	B8
10 12	90	-	69	75	10	M12 × 1.5	40	-	22	89	42.5	18	40	M22 × 1.5	14	-	-	-	-
23 28	118	-	88	95	25	M16 × 1.5	50	-	28	106	53	25	47	M27 × 2	16	1/2"	13	-	-
45 55	150	178	110	118	31.5	M18 × 1.5	63	115	28	132	63	29	53	M33 × 2	18	3/4"	19	50	48
63 80	173	208	126	140	36	M18 × 1.5	77	173	33	156	75	35.5	63	M42 × 2	20	1"	25	56	60
87 107	190	225	138	149	40	M18 × 1.5	80	190	37.5	165	80	35.5	66	M42 × 2	20	1"	25	63	60
125 160	212	257	159	173.5	45	M22 × 1.5	93	212	42.5	195	95	42.2	70	M48 × 2	22	1 1/4"	32	70	75

规格 Size	深	深	深	深	平键 keyed	花键 Splined	花键 Splined	重量 Weight										
α20° α25°	B9	deep	B10	B11	B12	deep	B13	B14	deep	B15	C	C1	C2	C3	GB1096-79	DIN5480	GB3478.1-83	kg
10 12	-	-	-	-	-	-	42	M33 × 2	18	-	95	100	9	10	键 6 × 32	W20 × 1.25 × 14 × 9g	EXT14Z × 1.25m × 30R × 5f	5.5
23 28	-	-	40.5	18.2	M8	15	53	M42 × 2	20	120	118	125	11	12	键 8 × 40	W25 × 1.25 × 18 × 9g	EXT18Z × 1.25m × 30R × 5f	12.5
45 55	M10	16	50.8	23.8	M10	16	-	-	-	126	150	160	13.5	16	键 8 × 50	W30 × 2 × 14 × 9g	EXT14Z × 2m × 30R × 5f	23
63 80	M12	18	57.1	27.8	M12	16	-	-	-	156	165	180	13.5	16	键 10 × 56	W35 × 2 × 16 × 9g	EXT16Z × 2m × 30R × 5f	33
87 107	M12	18	57.1	27.8	M12	18	-	-	-	160	190	200	17.5	20	键 12 × 63	W40 × 2 × 18 × 9g	EXT18Z × 2m × 30R × 5f	42
125 160	M16	24	66.7	31.8	M14	21	-	-	-	190	210	224	17.5	20	键 14 × 70	W45 × 2 × 21 × 9g	EXT21Z × 2m × 30R × 5f	63

A2F定量泵 / 马达 Fixed Displacement Pump / Motor A2F

元件尺寸 Unit Dimensions

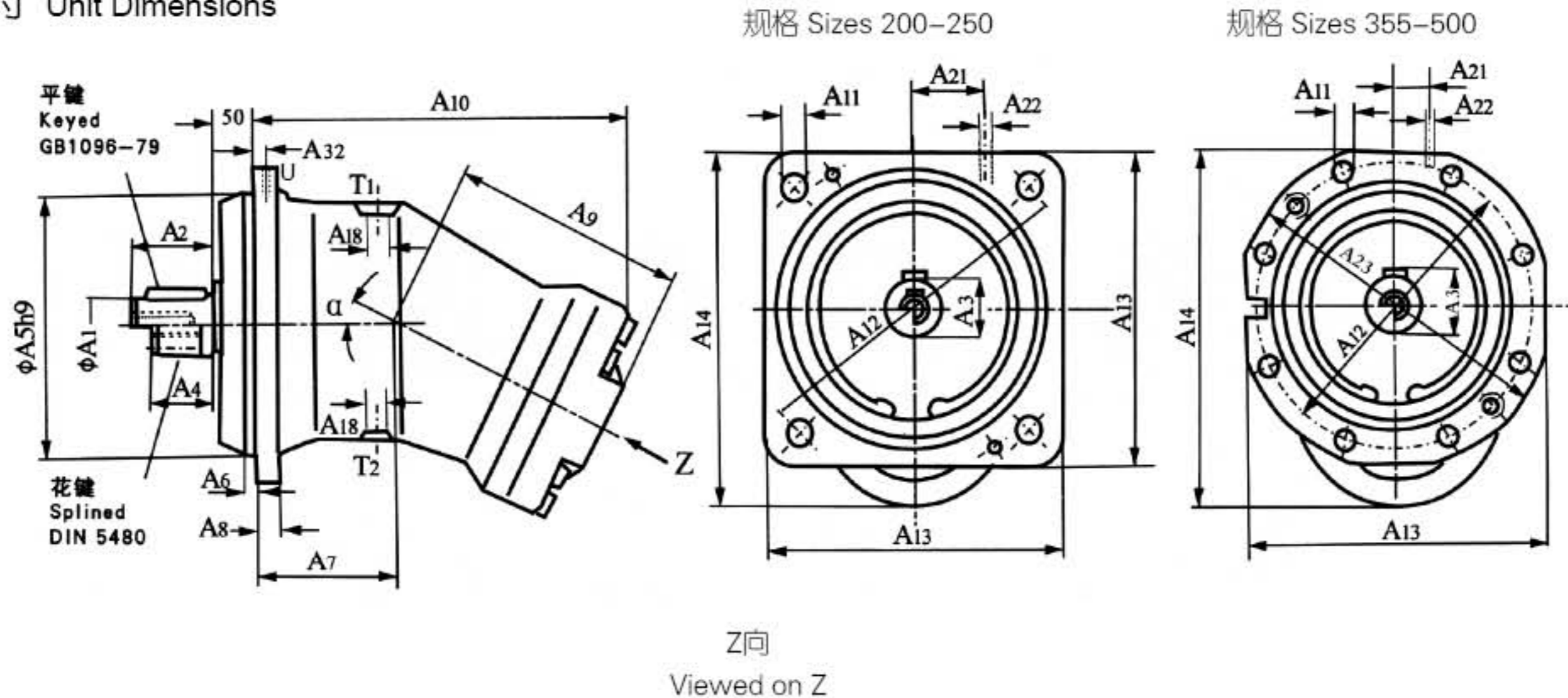

后盖

Port Plate

用于马达工况 for motor operation
用于泵工况 for pump operation
(闭式回路) (closed circuit)

1

后盖

Port Plate

用于泵工况 for pump operation
(开式回路) (open circuit)

2

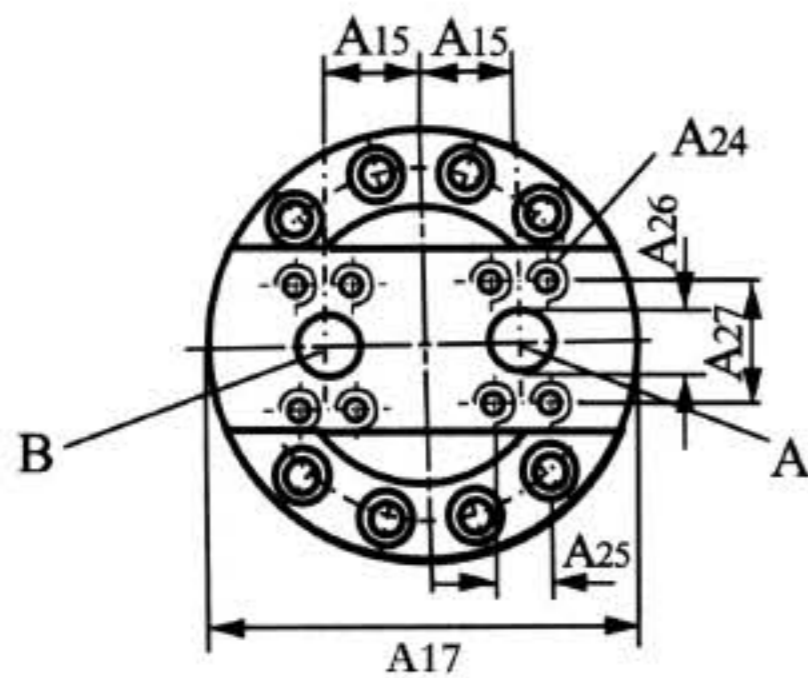

油口 Ports A, B:
SAE法兰 flange 6000 psi
见 A19
(see dimension A19)

油口 Port B(A):
SAE法兰 flange 6000 psi
见尺寸 A19
(see dimension A19)

逆时针旋转时后盖 2 旋转 180°

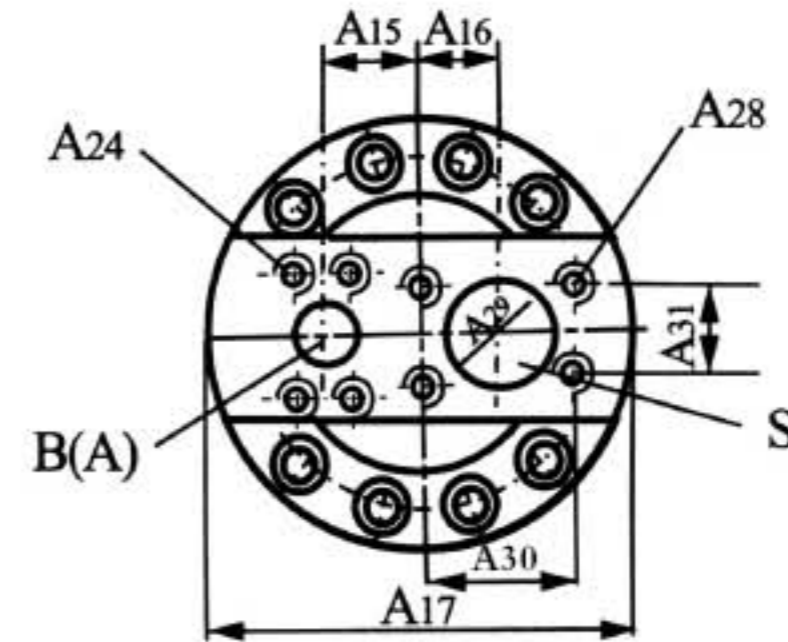

油口 Port S: SAE法兰 flange
规格 Sizes 200-355; 2500psi
规格 Sizes 500 | 200psi
见尺寸 A20
(see dimension A20)

For anti-clockwise rotation
port plate 2 is rotated 180°

规格

Size	α	A ₁	A ₂	A ₃	A ₄	A ₅	A ₆	A ₇	A ₈	A ₉	A ₁₀	A ₁₁	A ₁₂	A ₁₃	A ₁₄	A ₁₅	A ₁₆	A ₁₇	A ₁₈	A ₁₉	A ₂₀
200	21°	50 _{K6}	82	53.5	58	224	9	134	25	232	368	22	280	252	300	55	45	216	M22 × 1.5	1 1/4"	2 1/2"
250	26.5°	50 _{K6}	82	53.5	58	224	9	134	25	232	370	22	280	252	314	55	45	216	M22 × 1.5	1 1/4"	2 1/2"
355	26.5°	60 _{m6}	105	64	82	280	15	160	28	260	422	18	320	335	380	60	50	245	M33 × 2	1 1/2"	2 1/2"
500	26.5°	70 _{m6}	105	74.5	82	315	15	175	30	283	462	22	360	375	420	65	55	270	M33 × 2	1 1/2"	3"

规格	深										keyed Shaft		Splined Shaft		(kg)		
Size	A ₂₁	A ₂₂	A ₂₃	A ₂₄	deep	A ₂₅	A ₂₆	A ₂₇	A ₂₈	deep	A ₂₉	A ₃₀	A ₃₁	A ₃₂	GB1096-79	DIN5480	
200	70	M14 × 1.5		M14	22	31.8	32	66.7	M12	18	63	88.9	50.8	13	键 14 × 80	W50 × 2 × 24 × 9g	88
250	70	M14 × 1.5		M14	22	31.8	32	66.7	M12	18	63	88.9	50.8	13	键 14 × 80	W50 × 2 × 24 × 9g	88
355	35	M14 × 1.5	360	M16	24	36.6	40	79.4	M12	18	63	88.9	50.8	14	键 18 × 100	W60 × 2 × 28 × 9g	138
500	35	M18 × 1.5	400	M16	24	36.6	40	79.4	M16	24	75	106.4	62	15	键 20 × 100	W70 × 3 × 22 × 9g	185

北京华德液压工业 集团有限责任公司 BEIJING HUADE HYDRAULIC INDUSTRIAL GROUP CO.,LTD.	A2FE内藏式定量马达 Internal Installation Fixed Displacement Motor A2FE		RC90200/12.2004
	用于安装在机械齿轮箱中 For installation in mechanical gearboxes	斜轴式轴向柱塞结构 axial tapered piston, bent axis design	
	规格 Size 55-160	高压范围 Peak pressure 至 up to 40MPa	替代: Replace RC90200/09.2003



说明:

- 主要用于安装在机械齿轮箱中，例如：履带驱动齿轮箱。

特点:

- 马达的安装法兰设计在壳体的中间，这种结构允许马达几乎完全装进机械齿轮箱，从而提供一个十分紧凑的部件。
- 易于组装，仅需“插入”机械齿轮箱。
- 不需要考虑安装公差。

Description:

Hydrostatic play—in motors are intended primarily for installation in mechanical gearboxes, e.g. track drive gear boxes.

Special Features:

The design of the motor with the mounting flange in center of the housing allows it to be almost fully integrated into a mechanical gear box to give an extremely compact unit. No installation tolerances to consider. Easy assembly, simply plug—in to mechanical gearboxes.

Section

剖视图:

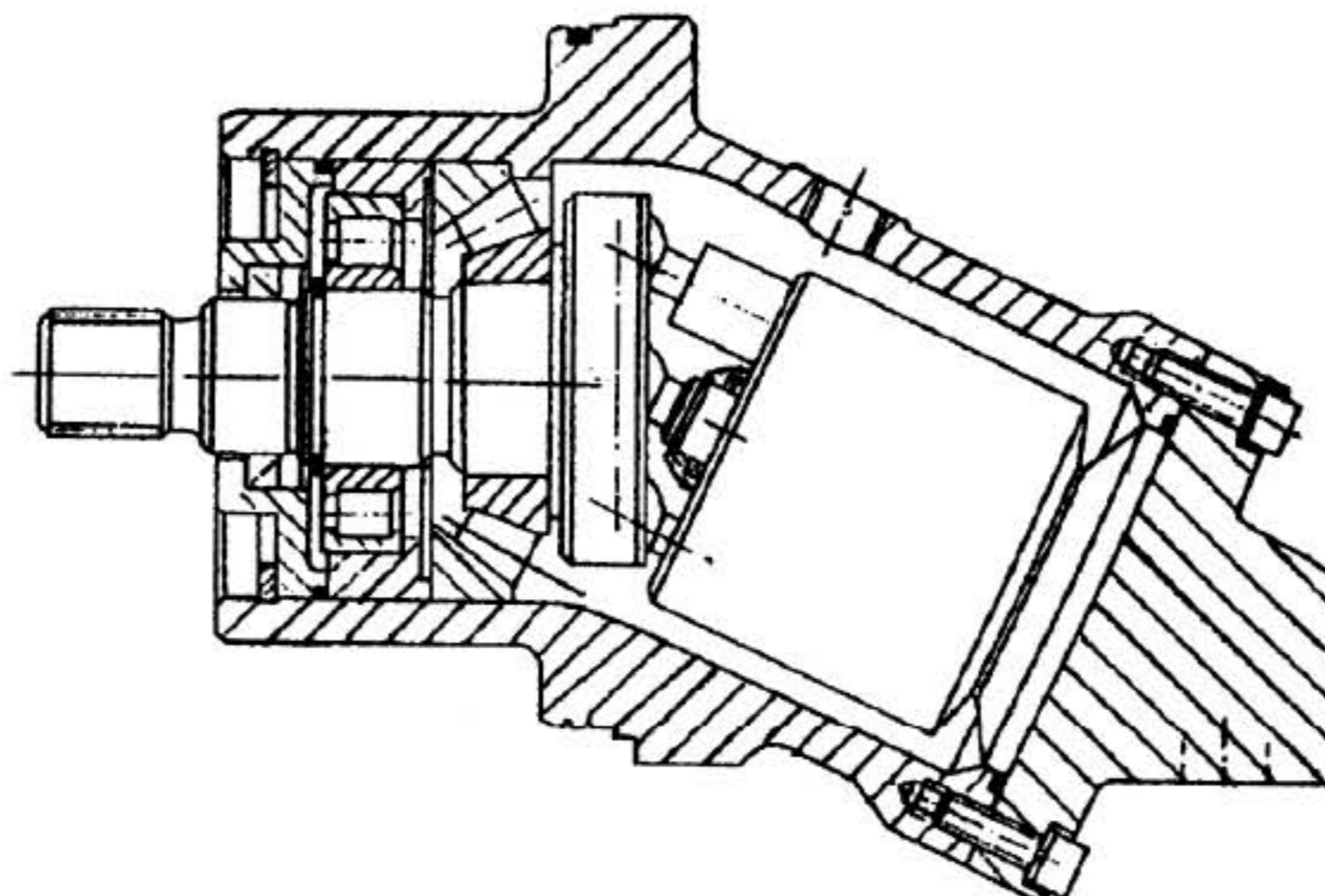

A2FE内藏式定量马达 Internal Installation Fixed Displacement Motor A2FE

油液的过滤

推荐过滤精度为10μm, 25—40μm的较粗过滤是可以使用, 但用10μm的过滤可延长使用寿命(降低磨损)

转速范围

最低转速 n_{min} 没限制, 如果要求高的旋转均匀性, 则 n_{min} 不低于50rpm. 最高转速见下表

安装位置

任选. 壳体必须始终充满油液

Filtration of Fluid

Recommended filtration: 10μm. Coarser filtration of 25—40μm, is possible, but with filtration of 10um.longer service life is Obtained(reduce wearing).

Speed Range

No limitation on minimum Speed n_{min} . if high uniformity of rotation is required, n_{min} should not be lower than 50 rpm. See table for maximum Speed n_{max} .

Mounting Position

Optional. The housing must always be filled with oil.

参数计算 Calculation of size

马达 Motor

流量 Flow

$$Q = \frac{V_g \cdot n}{1000 \cdot \eta_v} \quad [L/min]$$

扭矩 Torque

$$M = \frac{1.59V_g \cdot \Delta P \cdot \eta_{mh}}{10} \quad [Nm]$$

功率 Power

$$P = \frac{Mn}{9549} = \frac{Q \cdot \Delta P \cdot \eta_t}{60} \quad [KW]$$

转速 Speed

$$n = \frac{1000 \cdot Q \cdot \eta_v}{V_g} \quad [r/min]$$

V_g : 排量 geom.displacement(ml / r)

ΔP : 压差 Pressure differential(MPa)

n : 转数 Speed

η_v : 容积效率 volumetric efficiency

η_{mh} : 机械效率 mech.hydr.efficiency

η_t : 总效率 Overall efficiency

$$[\eta_t = \eta_v \cdot \eta_{mh}]$$

技术参数(理论值、未考虑 η_v 、 η_{mh} 数值经过圆整)

Technical Data (theoretical Values, without considering η_v , η_{mh} ·Values rounded off)

规格 size			55	80	107	125	160
排量 Displacement	V_g	ml/r	54.8	80	107	126.3	160
最高转速 Max.Speed	n_{max}	r/min	3750	3350	3000	3000	2650
最大流量 Max.flow	Q_{max}	L/min	206	268	321	379	424
扭矩常数 Torque constants	M_k	Nm/MPa	8.71	12.74	16.97	20.1	25.40
最大扭矩 Max.Torque $\Delta p=35MPa$	M	Nm	305	446	594	703.5	889
最大功率 Max.Power $\Delta p=35MPa$	P	kw	120	156	187	221	247
Moment of inertia 惯性矩 about drive shaft	J	Kgm ²	0.0052	0.0109	0.0167	0.0322	0.0532
重量 Weight(approx)		Kg					

A2FE内藏式定量马达 Internal Installation Fixed Displacement Motor A2FE

元件尺寸 Unite Dimensions

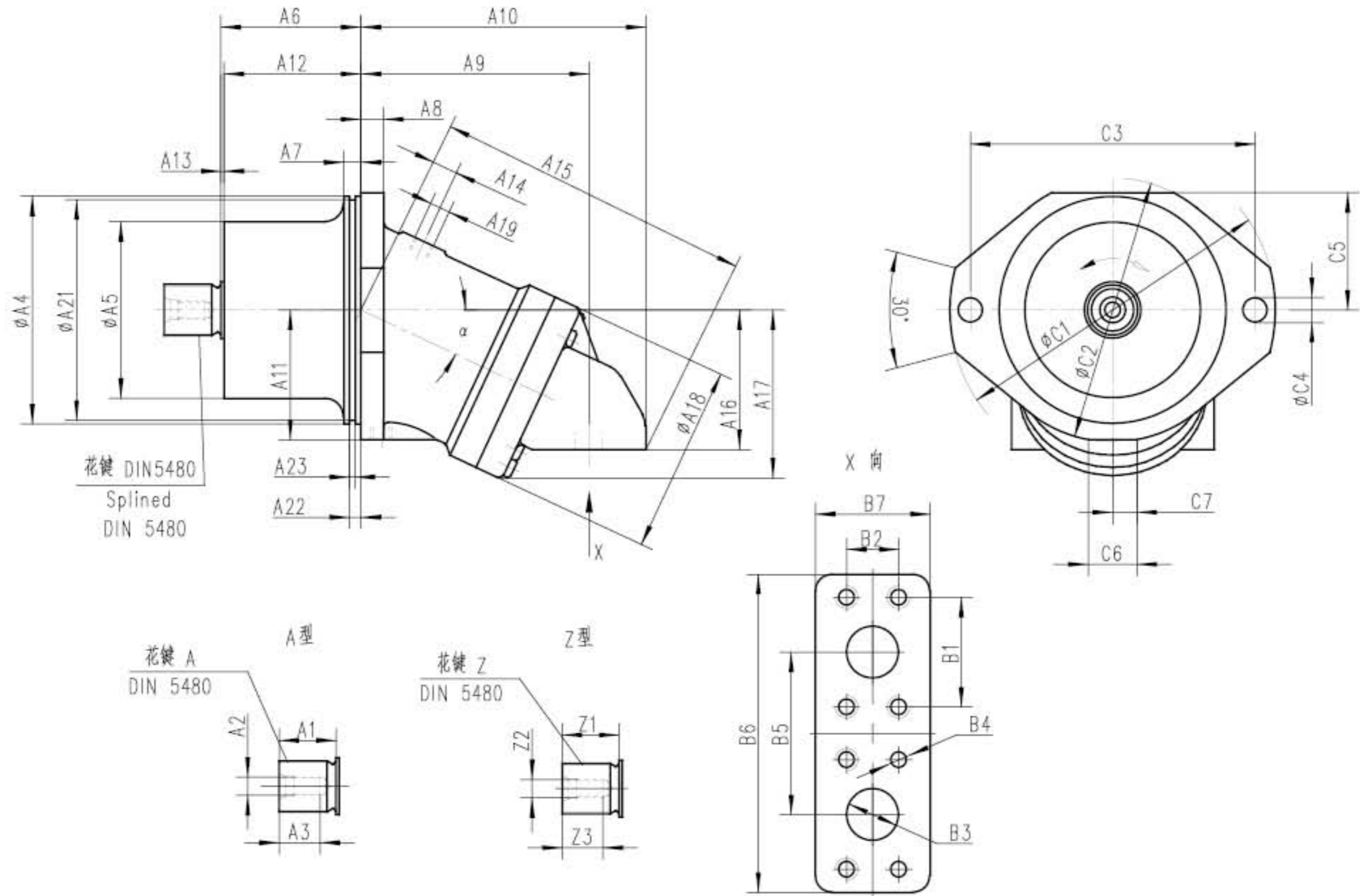

规格	A 型花键						Z 型花键										
size	α	Splined A DIN 5480			A_1	A_2	A_3	Splined Z DIN 5480			Z_1	Z_2	Z_3	A_4	A_5	A_6	A_7
55	25°	W35 × 2 × 30 × 16 × 9g			40	M12	28	W35 × 2 × 30 × 16 × 9g			35	M12	28	160h6	120	92.3	15
80	25°	W40 × 2 × 30 × 18 × 9g			45	M12	28	W40 × 2 × 30 × 18 × 9g			40	M12	28	190h6	139	110.8	15
107	25°	W45 × 2 × 30 × 21 × 9g			50	M16	36	W45 × 2 × 30 × 21 × 9g			45	M12	28	200h6	155	122.8	15
125	30°	W45 × 2 × 30 × 21 × 9g			50	M16	36	W45 × 2 × 30 × 21 × 9g			45	M12	28	200h6	155	123	15
160	25°	W50 × 2 × 30 × 24 × 9g			55	M16	36	W50 × 2 × 30 × 24 × 9g			50	M16	36	200h6	170	122.8	15

规格	深																
size	A_8	A_9	A_{10}	A_{11}	A_{12}	A_{13}	A_{14}	A_{15}	A_{16}	A_{17}	A_{18}	$A_{19}(J)$	deep	A_{20}	A_{21}	A_{22}	A_{23}
55	18	151	175	109	108	2.8	34.5	193.5	82.6	109.4	134	M18 × 1.5	12	63	151.62	10.55	7.1
80	20	160	187	113	108	2.8	18	218	108	136	160	M18 × 1.5	12	80	183.7	10	5.2
107	20	152	206	114	120	2.8	25	230	116	146	165	M18 × 1.5	12	75	193.7	10.2	5.2
125	20	143	178	105	120	3	25	210	112	148	165	M18 × 1.5	12	76	193.7	10	5.2
160	20	222	255	134	121.7	3.5	45	313.1	136	175	195	M22 × 1.5	14	93	191.62	10.55	7.1

规格	深																O 型圈 GB3452.1-83	
size	R	B_1	B_2	B_3	B_4	deep	B_5	B_6	B_7	C_1	C_2	C_3	C_4	C_5	C_6	C_7	O-Ring	
55	10	50.8	23.8	19	M10	17	75	147	48	235	190	200	18	82	40	20	$\phi 150 \times 5.3$	GB3452.1-83
80	10	57.2	27.8	25	M12	17	84	166	66	260	220	224	22	98	40	0	$\phi 180 \times 4$	DIN
107	16	66.7	31.8	32	M14	19	99	194	70	286	232	250	22	103	40	20	$\phi 192 \times 4$	DIN
125	16	66.7	31.8	32	M14	19	99	194	70	286	232	250	22	103	40	20	$\phi 192 \times 4$	DIN
160	12	66.7	31.8	32	M14	19	99	194	70	286	232	250	22	104	42	20	$\phi 190 \times 5.3$	GB3452.1-83

北京华德液压工业 集团有限责任公司 BEIJING HUADE HYDRAULIC INDUSTRIAL GROUP CO.,LTD.	A2FE内藏式定量马达 Fixed Displacement Plug-In Motor A2FE		RC90300/12. 2004
	6系列, 弯轴结构轴向锥型柱塞元件 Series 6, axial tapered piston rotary group of—bent axis design 用于安装在机械齿轮箱中 for mounting in mechanical gearboxes		
	规格Size 28—355	公称压力35MPa 最高压力40MPa Nominal pressure Peak press	替代: ReplaceRC90300/09.2003

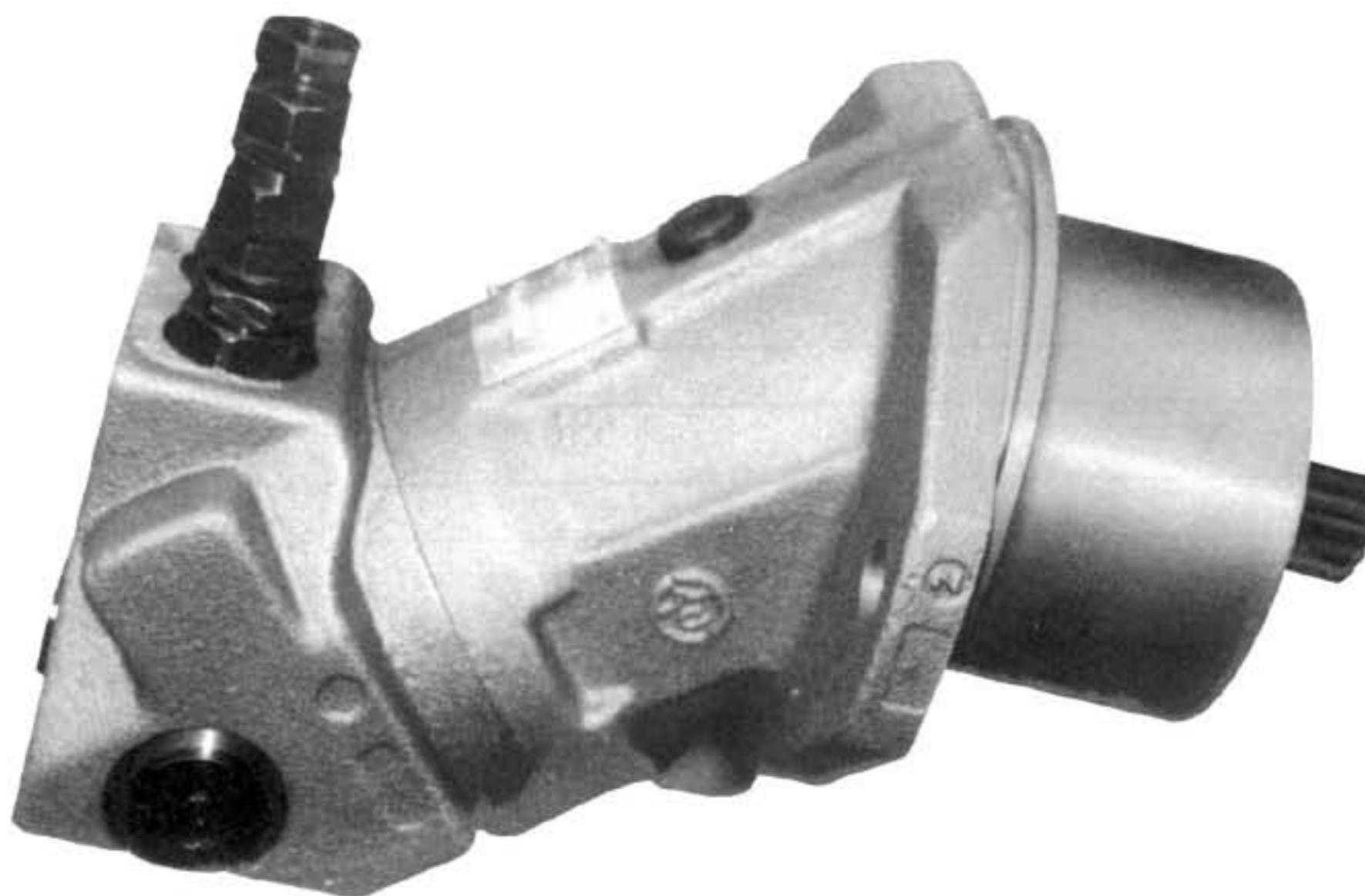

A2FE内藏式定量马达装有一套弯轴结构的标准轴向锥形柱塞旋转组件。

液压内藏式马达主要用来安装在机械齿轮箱中, 例如, 履带驱动轮箱。

马达的安装法兰设计在壳体的中间, 这种结构允许马达几乎完全装进机械齿轮箱, 从而提供一个十分紧凑的部件。

内藏式马达部件的特殊优点是:

- 整个部件, 已组装和试验
- 易于组装, 仅需“插入”机械齿轮箱
- 不需要考虑安装公差。

The fixed displacement plug—in motor A2FE is equipped with a standard axial tapered piston rotary group of bent axis design.

Hydrostatic plug—in motors are intended primarily for installation in mechanical gearboxes, e.g.track drive gear boxes.

The design of the motor with the mounting flange in the center of the housing allows it to be almost fully integrated into a mechanical gearbox to give an extremely compact unit.

The particular advantages of the plug—in motor over kit designs are:

- complete unit;
- ready assembled and tested
- easy assembly

Integral plug—in to mechanical gearboxes.

- no installation tolerances to consider.

A2FE内藏式定量马达 Fixed Displacement Plug-In Motor A2FE

型号说明 Type Code

HD - A2F E 80 W 61 A 11

华德液压 HUADE HYDRULIC

马达型号 Motor Type

定量马达 A2F
Fixed Displacement Motor

A2F

安装形式 Mounting Type

内藏式
Internal Installation

E

规格 Size

排量 ml/r Displacement	28	32	45	56	63	80	90	107	125	160	180	250	355
----------------------	----	----	----	----	----	----	----	-----	-----	-----	-----	-----	-----

旋转方向 Direction of Rotation

双向 Alternation

W

结构形式 Series

28	32	45	56	63	80	90	107	125	160	180	250	355
----	----	----	----	----	----	----	-----	-----	-----	-----	-----	-----

61

轴伸 Shaft end

花键 DIN5480
Splined Shaft

Z

A

	28	32	45	56	63	80	90	107	125	160	180	250	355
Z	○	○	●	●	●	●	●	●	●	●	●	●	●
A	○	○	●	●	●	●	●	●	●	●	●	●	-

○ : 没有

● : 有

后盖 port plate

11

A2FE内藏式定量马达 Fixed Displacement Plug-In Motor A2FE

技术数据

液压油

我们要求在项目开始前, 参阅关于液压油的选择和应用条件的详细资料, 矿物油、环境可接受的液压油和难燃液压油。

当使用HF液压油或环境可接受的液压油时, 应考虑降低工作参数。如有必要请与我们技术部门联系(请标明所使用液压油的牌号)。

工作粘度范围

为获得最佳效率和使用寿命, 我们推荐工作粘度在以下范围内选择(在工作温度下):

$$V_{\text{opt}} = \text{工作粘度 operating viscosity } 16\text{--}36 \text{ mm}^2/\text{s}$$

闭式回路中针对回油温度, 开式回路中针对油箱温度。

粘度极限

粘度极限值如下:

规格 Size 28...180

$$V_{\text{min}} = 5 \text{ mm}^2/\text{s},$$

$$V_{\text{max}} = 1600 \text{ mm}^2/\text{s},$$

规格 Size 355

$$V_{\text{min}} = 10 \text{ mm}^2/\text{s},$$

$$V_{\text{max}} = 1000 \text{ mm}^2/\text{s},$$

请注意一些部位的温度也不可超过最高油温(如轴承部位)。

-25°C到-40°C的温度, 在某些安装部位需要特别测量。其它资料请与我们联系。

选择图 Selection diagram

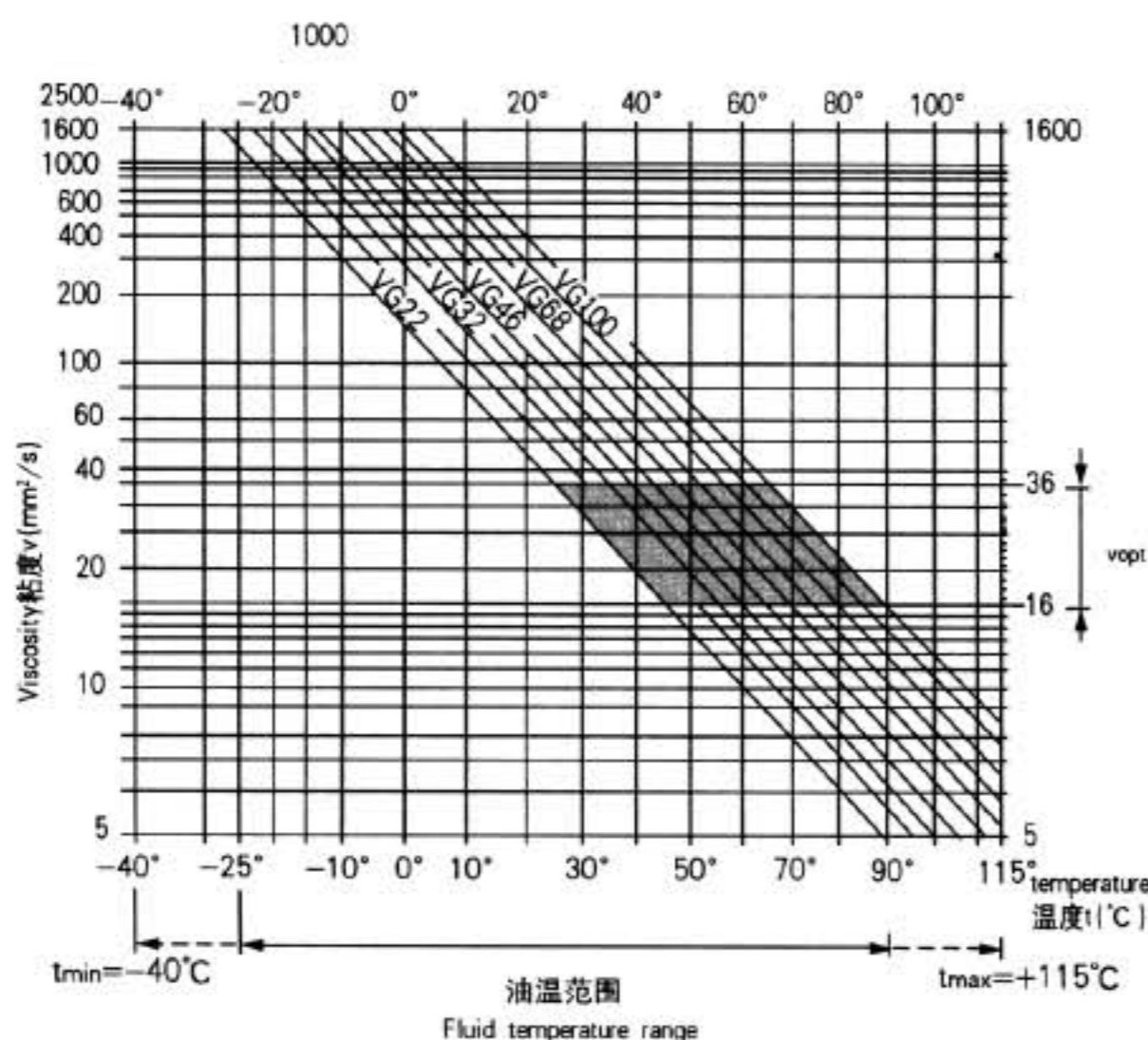

Technical Data

Fluid

We request that before starting a project detailed information about the choice of pressure fluids and application conditions are taken from our catalogue sheets mineral oil, environmentally acceptable hydraulic fluids and fire resistant hydraulic fluids.

When using HF-or environmentally acceptable hydraulic fluids possible imitations for the technical data have to be taken into consideration. If necessary please consult our technical department (please indicate type of the hydraulic fluid).

Operating Viscosity range

In order to obtain optimum efficiency and service life, we recommend that the operating viscosity (at operating temperature) be selected from within the range:

Referred to ambient temperature in a closed circuit, tank temperature in an open circuit.

Viscosity limits

The limiting values for viscosity are as follows:

对于短期最高允许温度 $t_{\text{max}} = 115^\circ\text{C}$

对于短期冷态启动 ($t_{\text{min}} = -40^\circ\text{C}$)

对于短期最高泄漏油温 $t_{\text{max}} = 90^\circ\text{C}$

对于短期冷态启动 ($t_{\text{min}} = -25^\circ\text{C}$)

Please note that the max fluid temperature is also not exceeded in certain areas (for instance bearing area)

At temperatures of -25°C up to -40°C special measures may be required for certain installation positions. Please contact us for further information.

液压油选择说明

为正确选择液压油, 有必要了解与环境温度有关的循环油(闭式回路)或油箱(开式回路)的工作温度。液压油的选择应使得在工作温度范围内液压油的工作粘度在最佳范围 (V_{opt} , 见液压选择图阴影部分)内。对于每一种具体情况, 我们推荐在允许的范围内选择粘度较高者。

例如: 当环境温度为 $X^\circ\text{C}$ 、工作温度(闭式回路: 循环油温度; 开式在回路: 油箱温度)为 60°C 时, VG46和VG68均在工作粘度范围 (V_{opt} , 液压选择图阴影部分)内, 在此情况下应选择VG68。

注意: 泄漏油(壳体排放油)温度受压力和马达转速的影响总是高于回路或油箱的温度。但是油路中各处的温度对于规格28至180不能超过 115°C 、对于规格355不能超过 90°C 。如果因极端的工作参数或太高的环境温度而不能满足上述条件, 请与我方联系。

过滤

液压油过滤得越干净, 轴向柱塞元件的使用寿命就会越长。

为保证元件的正常工作, 最低的清亮度等级为:

NSA 1638, 9级

SAE, 6级

ISO / DIS 4406 18 / 15级

对于温度非常高 (90°C 至 115°C 最大, 对于规格355不允许)的液压油, 最低的清亮度等级为:

NSA 1638, 8级

SAE, 5级

ISO / DIS 4406, 17 / 14级

如不能满足上述条件, 请与供方联系。

Notes on the selection of the hydraulic fluid

In order to select the correct fluid, it is necessary to know the operating temperature in the circle oil (closed circuit) and in the tank (open circuit) in relation to the ambient temperature. The hydraulic fluid should be selected so that within the operating temperature range the operating viscosity lies within the optimum range (V_{opt}) (see shaded section of the selection diagram). We recommend that the highest possible viscosity range should be chosen in each case.

Example: At an ambient temperature of $X^\circ\text{C}$ tank temperature (closed circuit: the circuit oil temperature; open circuit: the tank temperature) is 60°C . With the operating viscosity range (V_{opt} : shaded area), this corresponds to viscosity range VG46 or VG68. VG68 should be selected.

Note: The leakage oil (case drain oil) temperature is influenced by temperature. However, any point in the circuit, the temperature can not exceed 115°C for size 28-180 or 90°C for size 355. If it is not possible to comply with the above conditions because of extreme operating parameters or high ambient temperatures please consult us.

Filtration

The finer the filtration the better the achieved purity grade of the pressure fluid and the longer the life of the axial piston unit.

To ensure the functioning of the axial piston unit a minimum purity grade of:

9 to NSA1638

6 to SAE

18 / 15 to ISO / DIS 4406 is necessary.

At very high temperature of hydraulic fluid (90°C to max. 115°C , not permissible for size 355) at least cleanliness class:

8 to NSA1638

5 to SAE

17 / 14 to ISO / DIS 4406 is necessary.

If above mentioned grades cannot be maintained please consult supplier.

A2FE内藏式定量马达 Fixed Displacement Plug-In Motor A2FE

技术数据 Technical Data

液流方向 Direction of Flow

顺时针方向clockwise	逆时针方向Anti-clockwise
A到(to)B	B到(to)A

转速范围 Speed range

最低转速 n_{min} 没有限制。如需要平稳运转,最低转速 n_{min} 不能低于50rpm。

There is no limitation on minimum speed n_{min} should not be allowed to fall below 50rpm.

最高允许转速见第15页上的参数表。

see table on page 15 for max. permissible speeds.

安装位置 Installation position

各种安装位置可在竖直方向(驱动轴向上)安装时,请与我方联系。启动前马达壳体必须充满液压油,并且在动作的整个过程中必须充满。

有关安装的详细资料,请在完成设计之前参阅我公司的样本。

When every installation position can be vertical(drive shaft up), please consult us. The motor housing must be filled with fluid prior the commissioning, and must remain full whenever it is operating.

For extensive information on installation position, please consult our data sheet before completing your design work.

符号 Symbol

油口Connections

A, B 工作管油口 service line ports

T 壳体泄油口 Case drain port

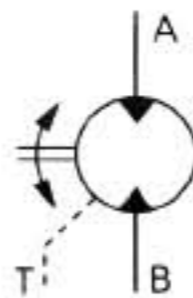

壳体泄油压力 Case drain pressure

转速和壳体泄油压力越低,密封寿命越长。

氟橡胶密封:

The lower of speed and case drain pressure, the longer of the seal life. >>viton<<shaft seal:

图中给出的数值是密封圈的允许值,不能超过。

The values given in the diagram are limiting values for the shaft seal and should not be exceeded.

泄油压力持续在允许范围的最大值上,将造成密封圈寿命的降低。

If the limiting values are exceeded, the seal life will be reduced.

对于规格28...180,不论转速高低在短时间($t < 5min$)泄油压力允许达到5bar.

For size 28—180, With out reference to the high or low of the speed, drain pressure are permitted to reach 5 bar in short terms.

在特殊工作条件下,需要限制这些数值。

On special working conditions, it should restrict these values.

注意: Note

马达最高允许转速在第15页上的表中给出。

Maximum permissible motor speeds are given in the table on page 15.

壳体最高允许压力 $P_{abs,max} = 10bar$ (规格28...180)

4bar (规格355)

Maximum permissible casing pressure $p_{abs,max} = 10bar$.(size28—180)

壳体压力值必须等于或高于作用在轴密封上的外部压力值。

The pressure in the housing must be the same as or greater than the external pressure on the shaft seal.

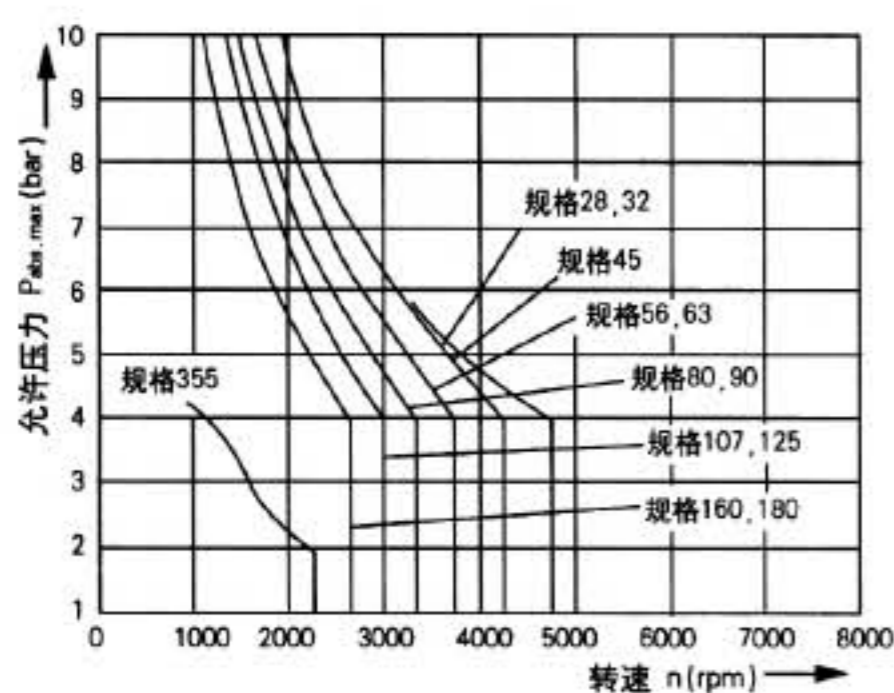

工作压力范围 Operating Pressure range

油口A或B的最高压力maximum pressure at port A or B

(压力数据满足DIN24312 pressure data meet DIN24312)

规格size28...180 轴伸shaft end A 轴伸shaft end Z

	规格size28...180	规格size28,45,56	规格size63,90
公称压力Nominal pressure P_n	40MPa	40MPa	35MPa
尖峰压力Peal pressure P_p	45Mpa	45Mpa	40MPa

注意:当轴伸z安装有径向负荷的驱动轮(小三角皮带轮)时有必要降低工作压力(请与我们联系)。

Note: when shaft and Z mounting with driving wheel(small triangle strap-wheel)of radial load. it is necessary to reduce the operating pressure, please consult US.

规格size355

公称压力Nominal pressure P_N

35MPa

尖峰压力Peal pressure P_{max}

40MPa

当承受脉冲载荷压力超过32MPa,我们建议使用标准的A型花键轴,A口和B口压力之和不能超过70MPa。

With pulsating loads above 32Mpa we commend using the model with splined shared, standard version A, the sum of the pressure at ports A and B may not exceed 70Mpa.

整体式换油阀

为避免闭式回路中过分发热,可能有必要装一个换油阀(安装在油口接板中)。

—开启压力 $\Delta P \geq 8bar$ 。(该值小于马达空载时的高压力)

—该阀中位关闭($\Delta P \leq 8bar$)

—换油流量见表:

Integral Flushing Valve

In order to prevent excessive heat buildup in dosed circuit operation, it is possible to fit a flushing valve(built into the portplate)

—switching pressure $\Delta P \geq 8bar$ (this value is lower than the starting pressure of an unloaded motor)

—closed in center position($\Delta P \leq 8bar$)

—flushing volume: see table.

规格 size	23—32	45—63	80—90
换油流量L / min Flushing volume	2. 5	3. 1	4. 1

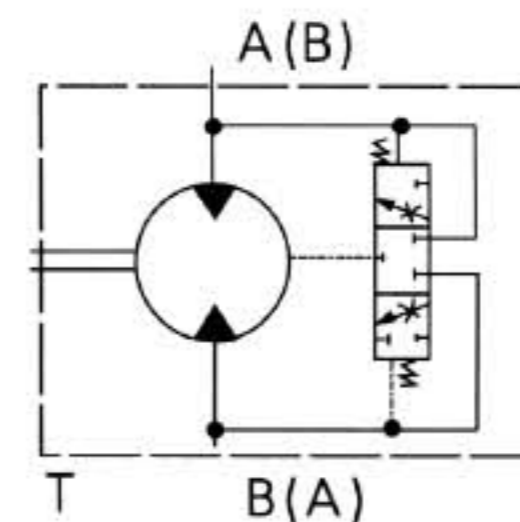

长寿命轴承Long-Life bearings (L) (规格size355)

(对于期望寿命较高并使用难燃液压油的马达)

该轴向柱塞马达的外部尺寸和标准结构

(非长寿命轴承)相同。可以从标准结构改为长寿命轴承结构形式。

(For anticipant life compare high and use fire resistant fluids)

The unit dimensions of axial tapered piston motor is same as standard series(not long life bearing).It can use long—life bearing replace standard series.

A2FE内藏式定量马达 Fixed Displacement Plug-In Motor A2FE

数据表(理论值, 未考虑mh和v; 数据经过圆整)

Table of values(theoretical values, without considering mh and v, valaes rounded)

规格	Size			28	32	45	56	63	80	90	107	125	160	180	355
排量	Displacement	V_g	cm^3	28.1	32.0	45.6	56.1	63.0	80.4	90.0	106.7	125.0	160.4	180.0	355
最高转速	n_{max}	rpm	6300	6300	5600	5000	5000	4500	4500	4000	4000	3600	3600	2240	
				Max.speed	n_{max} 间歇	rpm	6900	6900	6200	5500	5500	5000	5000	4400	4400
最大流量	Max.flow	Q_{max}	L/min	176	201	255	280	315	360	405	427	500	577	648	795
扭矩常数	Torgue constamts	M_k	Nm/MPa	4.45	5.09	7.25	8.9	10	12.7	14.3	17	19.9	25.4	28.6	56.5
扭矩 =40MPa		M	Nm	178	204	290	356	400	508	572	680	796	1016	1144	1976 ²
壳体容积	Case volame		L	0.20	0.20	0.33	0.45	0.45	0.55	0.55	0.8	0.8	1.1	1.1	3.5
绕驱动轴的惯性矩	moment of inertia about druve axis	J	kgm^2	0.0012	0.0012	0.0024	0.0042	0.0042	0.0072	0.0072	0.0116	0.0116	0.0220	0.0220	0.102
重量(近似)	Weight		kg	10.5	10.5	15	18	19	23	25	34	36	47	48	110

1)间歇最高转速: 在卸货和超边行驶时超速 $t < 5$ 秒和 $\Delta P < 150$ bar Intermittent max. speed: overspeed at discharge and overtaking travel operations, $t < 5$ sec. and $\Delta P < 150$ bar

2) $\Delta P = 35$ Mpa

规格的计算 Calculation of size

流量 Flow $Q = \frac{V_g \cdot n}{1000 \cdot \eta_v}$ [L/min]

输出转速 Output speed $n = \frac{q_v \cdot 1000 \cdot \eta_v}{V_g}$ [rpm]

输出扭矩 Output torque $T = \frac{V_g \cdot \Delta P \cdot \eta_{mh}}{20 \cdot \pi}$ [Nm]

$$= \frac{1,59 \cdot V_g \cdot \Delta P \cdot \eta_{mh}}{10} \quad [Nm]$$

或 $T = T_k \cdot \Delta P \cdot \eta_{mh}$ [Nm]

输出功率 Output power $p = \frac{T \cdot n}{9549}$
 $= \frac{Q \cdot \Delta P}{600} \cdot \eta_t$

$V_g =$: 每转体积排量geometric displacement per rev (ml)

$T =$ 扭矩torque (Nm)

$\Delta P =$ 压力差pressure differential (Mpa)

$n =$ 转速speed (rpm)

$T_k =$ 扭矩常数torque constants (Nm/MPa)

$\eta_v =$ 容积效率volumetric efficiency

$\eta_{mh} =$ 机械液压效率mech.-hyd. efficiency

$\eta_t =$ 总效率overall efficiency

A2FE内藏式定量马达 Fixed Displacement Plug-In Motor A2FE

元件尺寸 Unit Dimensions

规格 size 28...180

油口接板 10 port plate

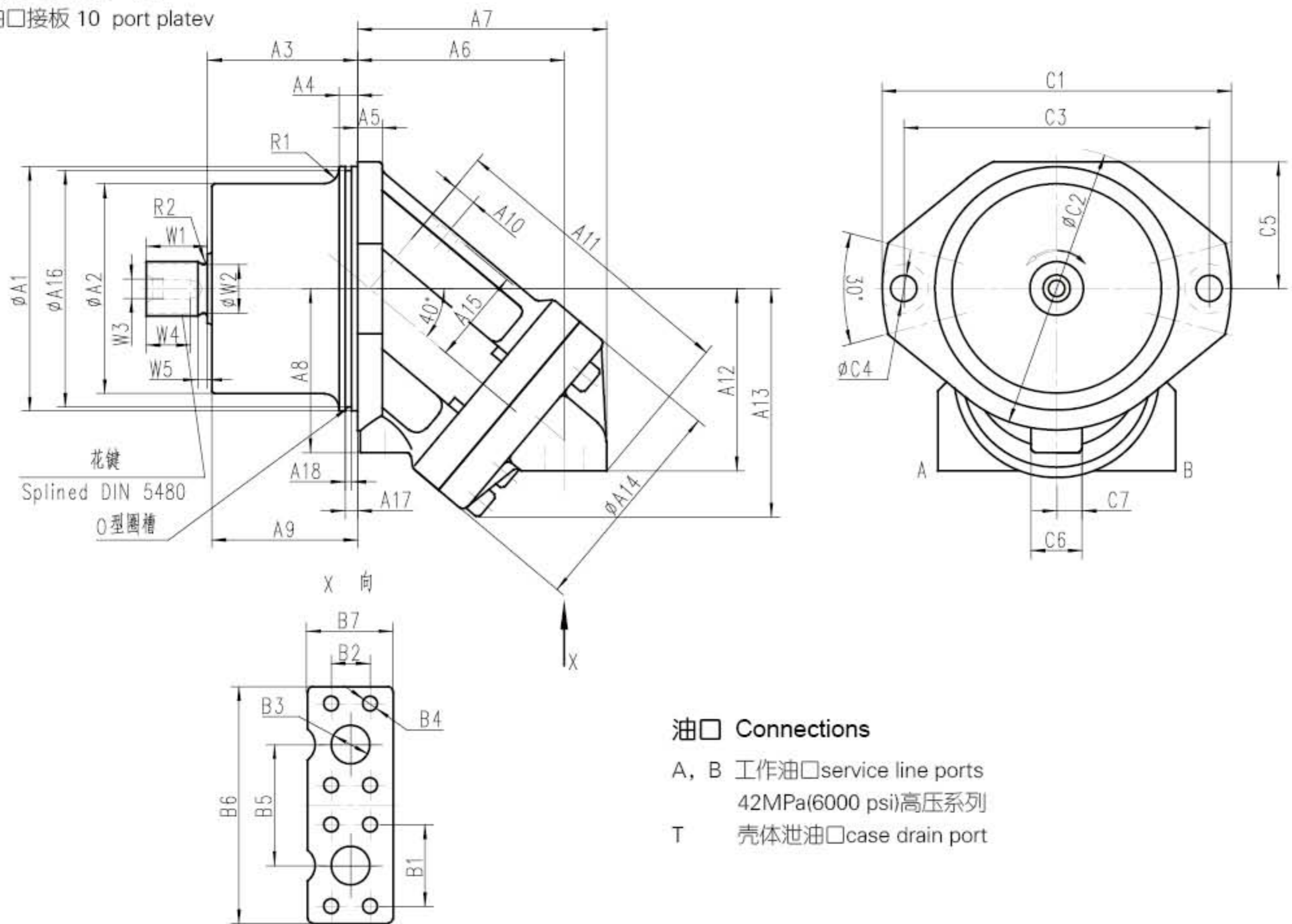

油口 Connections

A, B 工作油口 service line ports

42MPa(6000 psi)高压系列

T 壳体泄油口 case drain port

规格 Size	A1	A2	A3	A4	A5	A6	A7	A8	A9	A10	A11	A12	A13	A14	A15	A16	A17	A18
28.32	135 _{h6}	94 _{±1.5}	88.8	15	16	94	114	95	87.1	19	149	91	106	106	51.5	128.7	10	5.2
45	160 _{h6}	117 _{-2^{+1.5}}	92.3	15	18	108	132	106	90	18	167	102	119	118	52	153.7	10	5.2
56.63	160 _{h6}	121 _{-0.5}	92.3	15	18	122	146	109	90	18	176	107	130	128	60	151.62	10	7.1
80.90	190 _{h6}	139 _{±1.3}	110.8	15	20	127	157	123	106	15	198	121	158	138	66	183.7	10	5.2
107.125	200 _{h6}	151 _{±1.3}	122.8	15	20	143	178	135	119	18	224	136	158	150	69	193.7	10	5.2
160.180	200 _{h6}	171.6 _{-0.5⁰}	122.8	15	20	169	204	134	119.3	19.5	244	149	187	180	79	193.7	10	5.2
规格 Size	R1	O型圈 ¹⁾	B1	B2	B3	B4	B5	B6	B7	工作油口 Service port A,B		泄油口 drain port T						
28.32	10	126 × 4	40.5	18.2	13	M8,深 deep15	59	115	40	SAE1/2"		M16 × 1.5,深 deep12						
45	10	150 × 4	50.8	23.8	19	M10,深 deep17	75	150	48	SAE3/4"		M18 × 1.5,深 deep12						
56.63	10	150 × 4	50.8	23.8	19	M10,深 deep17	75	148	47	SAE3/4"		M18 × 1.5,深 deep12						
80.90	10	180 × 4	57.2	27.8	25	M12,深 deep17	84	166	60	SAE1"		M18 × 1.5,深 deep12						
107.125	16	192 × 4	66.7	31.8	32	M14,深 deep19	99	194	70	SAE1 1/4"		M18 × 1.5,深 deep12						
160.180	12	192 × 4	66.7	31.8	32	M14,深 deep19	99	194	70	SAE1 1/4"		M22 × 1.5,深 deep12						
规格 Size	C1	C2	C3	C4	C5	C6	C7											
28.32	188	154	160	14	71	42	12.5											
45	235	190	200	18	82	47.5	15											
56.63	235	190	200	18	82	36	18											
80.90	260	220	224	22	98	40	20											
107.125	286	232	250	22	103	40	20											
160.180	286	232	250	22	104	42	21											

1)O型圈不包括在供货量中 The O-ring not comprised in delivery volume

A2FE内藏式定量马达 Fixed Displacement Plug-In Motor A2FE

轴伸 shaft ends

花键轴 DW5480

规格 Size	轴伸 shaft end	W1	W2	W3	W4	W5	R2
28.32	A W30 × 2 × 30 × 14 × 9g	35.2	24.6	M10	22	8	1.6
28	Z W25 × 1.25 × 30 × 18 × 9g	43.2	21.6	M8	19	15	1.6
45	A W32 × 2 × 30 × 14 × 9g	35	26.6	M12	28	8	1.6
	Z W30 × 2 × 30 × 14 × 9g	35	24.6	M12	28	8	1.6
56.63	A W35 × 2 × 30 × 16 × 9g	40	29.6	M12	28	8	1.6
	Z W30 × 2 × 30 × 14 × 9g	35	24.6	M12	28	8	1.6
80.90	A W40 × 2 × 30 × 18 × 9g	45	34.6	M16	36	8	2.5
	Z W35 × 2 × 30 × 16 × 9g	40	29.6	M12	28	8	1.6
107.125	A W45 × 2 × 30 × 21 × 9g	50	39.6	M16	36	8	2.5
	Z W40 × 2 × 30 × 18 × 9g	45	34.6	M12	28	8	2.5
160.180	A W50 × 2 × 30 × 24 × 9g	55	44.6	M16	36	11	4
	Z W45 × 2 × 30 × 21 × 9g	50	39.6	M16	36	8	2.5

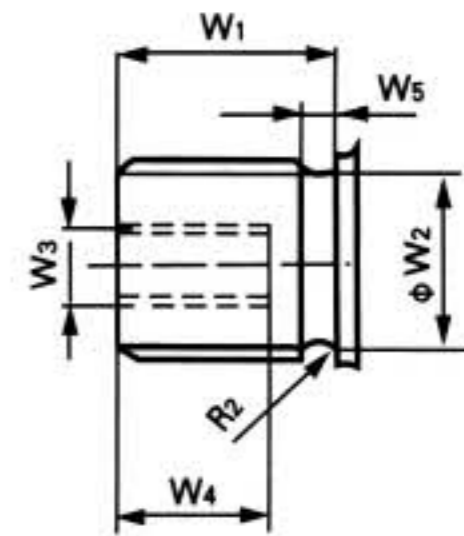

元件尺寸 Unit Dimensions

规格 size 355

油口接板 port plate 10

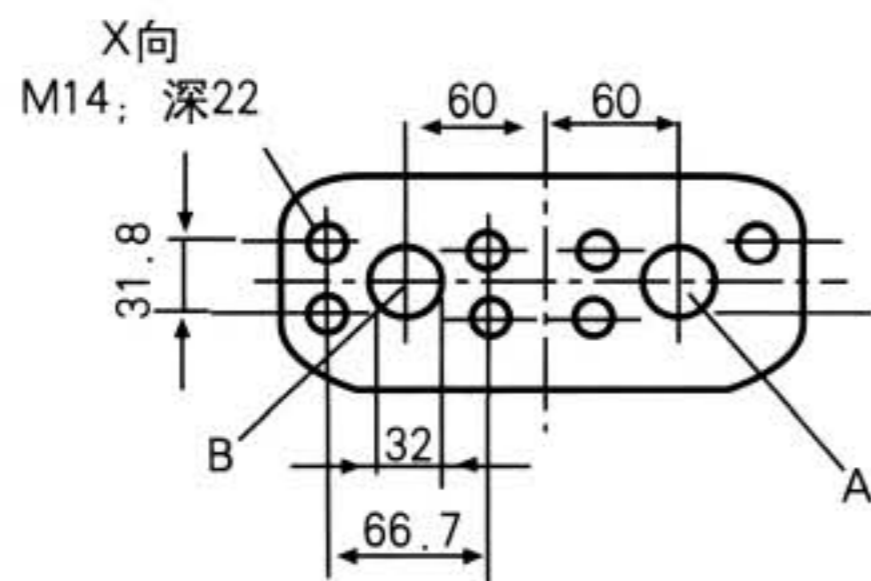
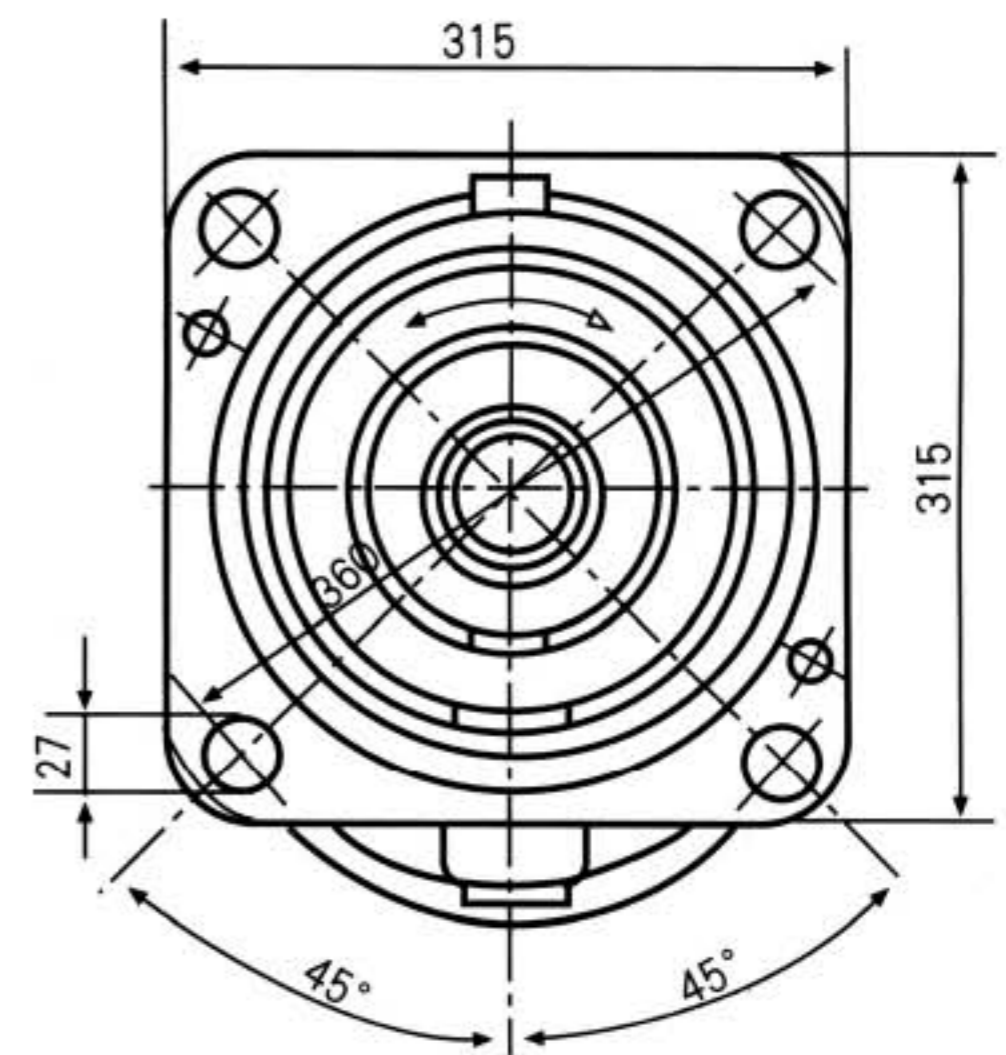
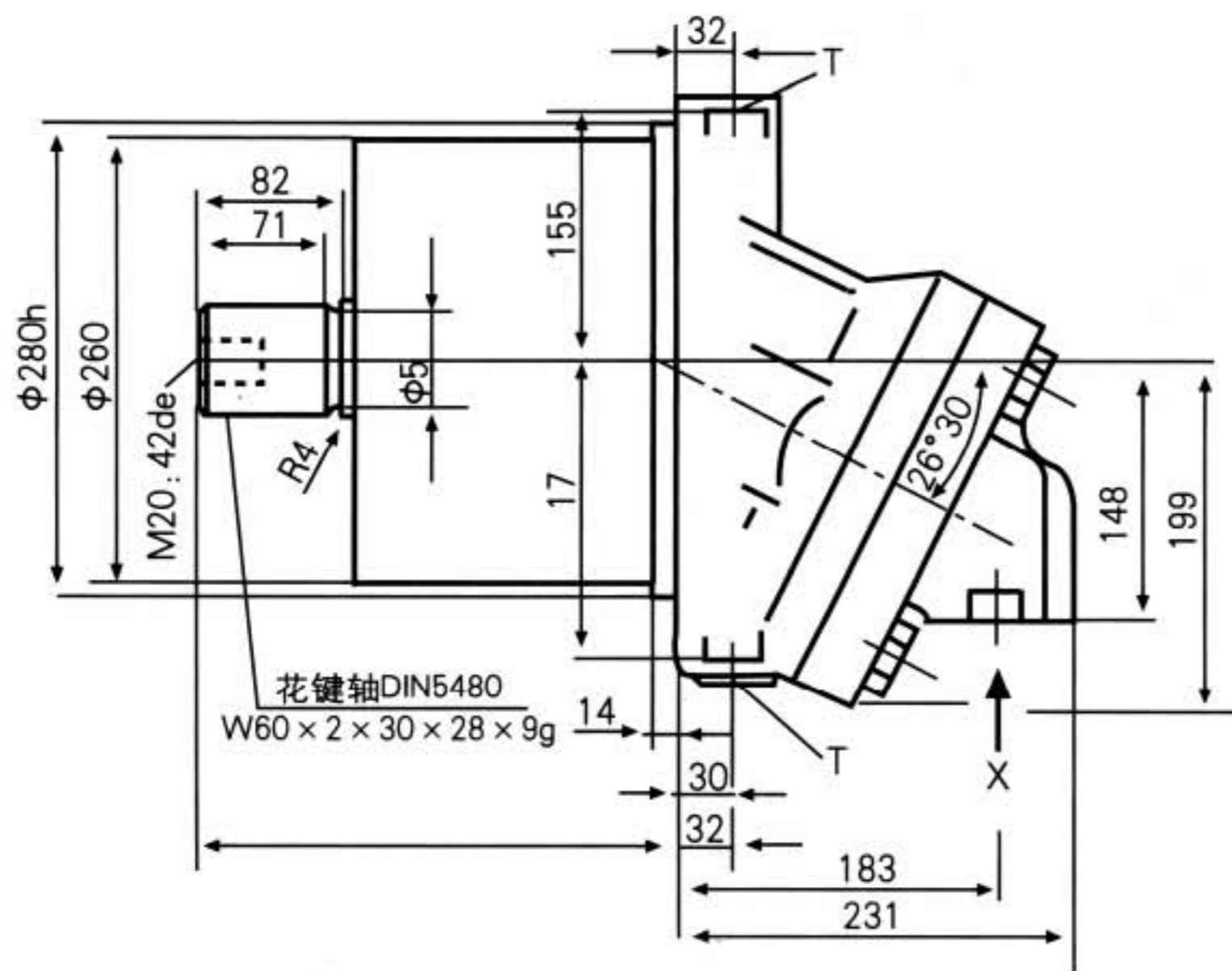

油口 Connections

A, B 工作油口 service line ports SAE₁/4" 42MPa(6000 psi)高压系列

T₁, T₂ 壳体泄油口(一个被塞住) M33 x 2 case drain port

A2FE内藏式定量马达 Fixed Displacement Plug-In Motor A2FE

油口接板 port plates 17, 18。带有整体式溢流阀的油口接板，适合于安装一个平衡阀

With integral flooding valve, is fit for installing a equilibrium valve

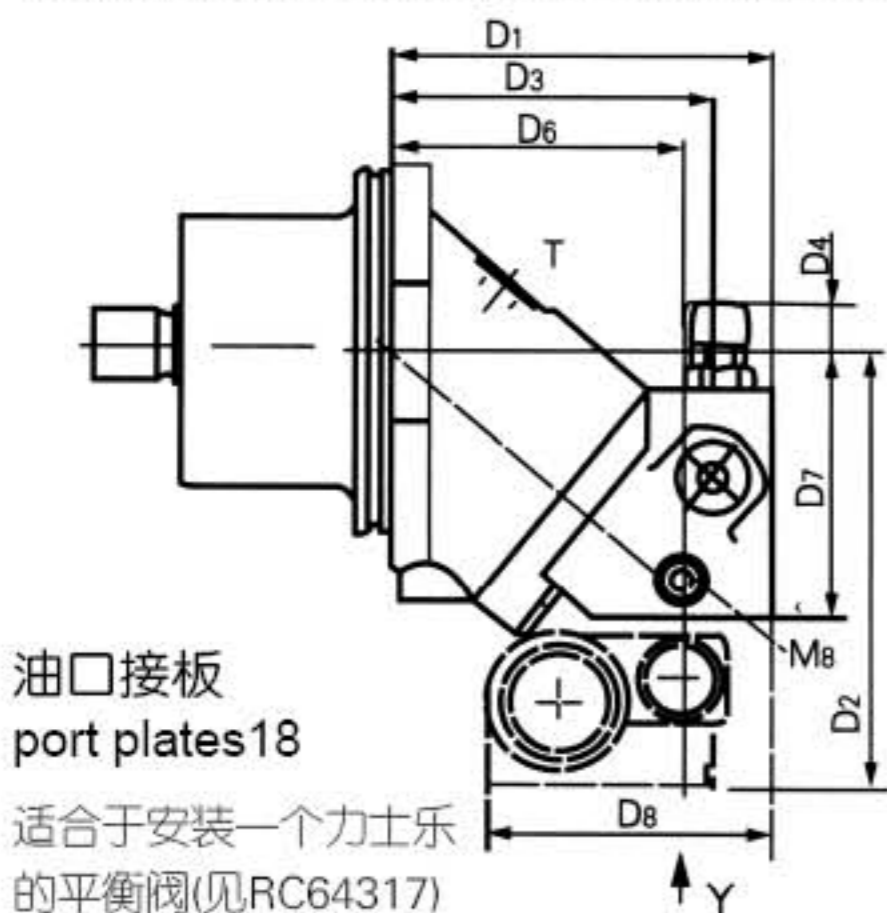

油口接板 port plates 18

适合于安装一个力士乐的平衡阀(见RC64317)

fit for installing a REZROTH equilibrium valve
 MHB16...18(A2FE28, 32, 45)
 MHB16...18E(A2FE56, 63)
 MHB20...11(A2FE56, 63)
 MHB20...18(A2FE80, 90)
 MHB25...18(A2FE107, 125, 160, 180)

油口接板 17,181 (单级溢流阀)

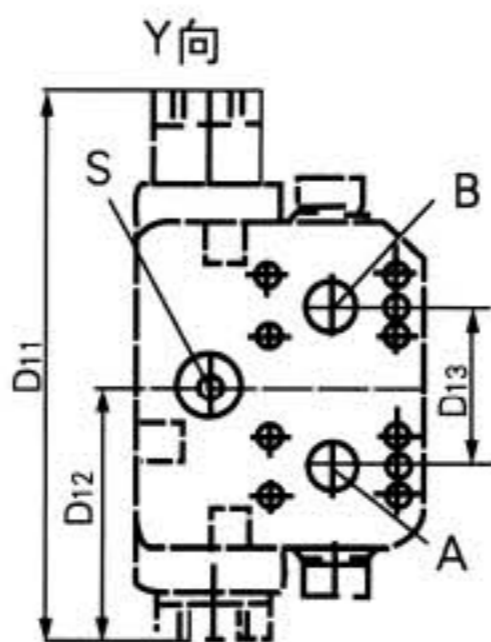

油口接板 port plates 17

适合于安装一个力士乐的平衡阀(见RC64317)

fit for installing a REZROTH equilibrium valve
 MHB20...18E(A2FE 107,125)

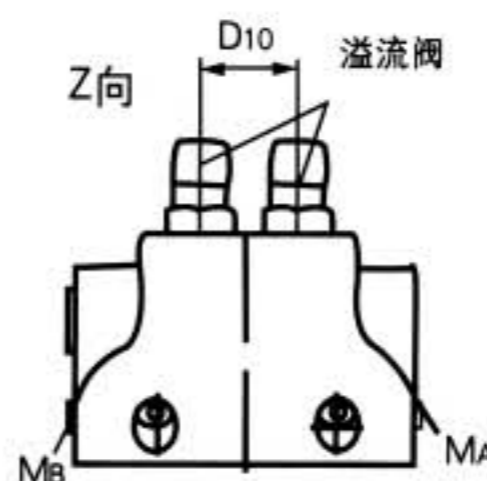

油口 connections

A, B 工作油口 service port SAE, 420bar (见下表 see below table) (6000 psi) 高压系列 high pressure series
 S 升压口 (pressure line) (见下表 see below table)
 MA, MB 测试口 (已被塞住) M12 x 1.5 test line (be stuffed)

平衡阀不包含在型号标记中，需单独标注。
 The equilibrium valve is not comprised to model sign, need single label

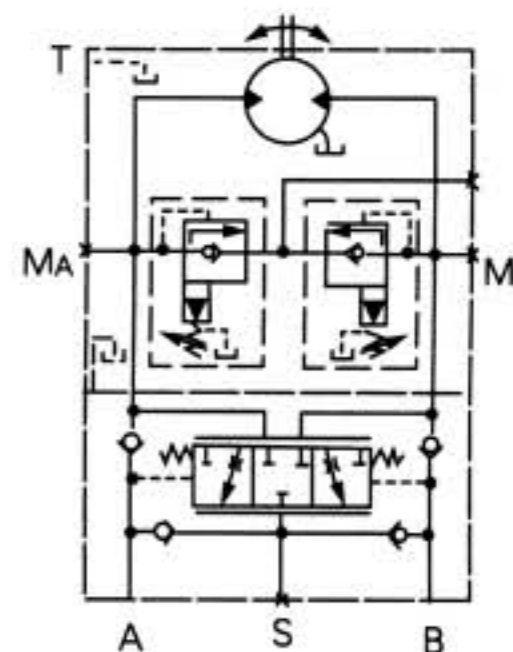

油口接板 port plates 19

带有整体式溢流阀
 With integral flooding valve

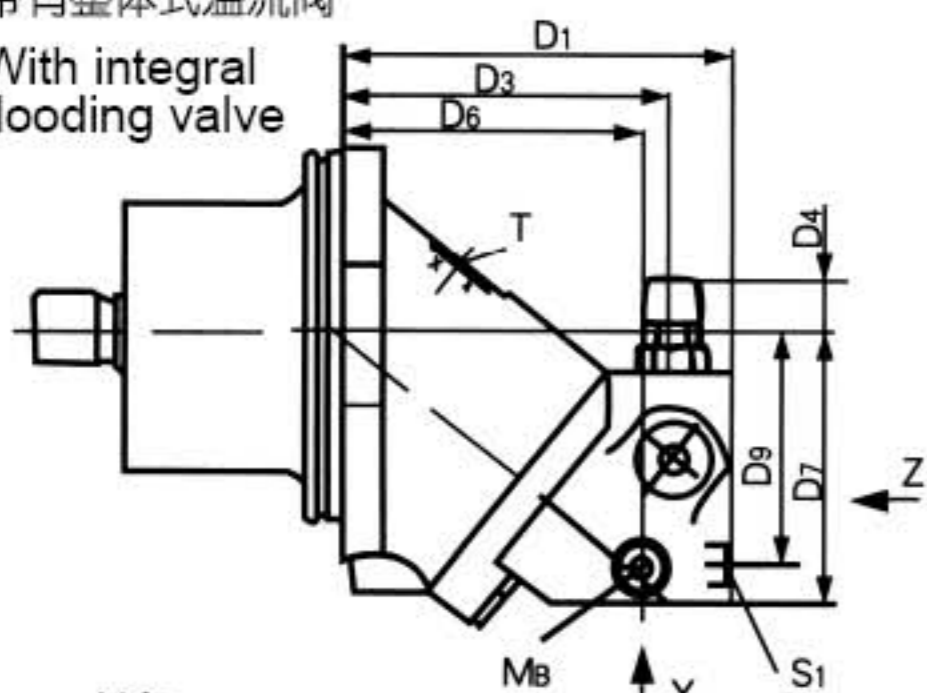

Y向 direction Y

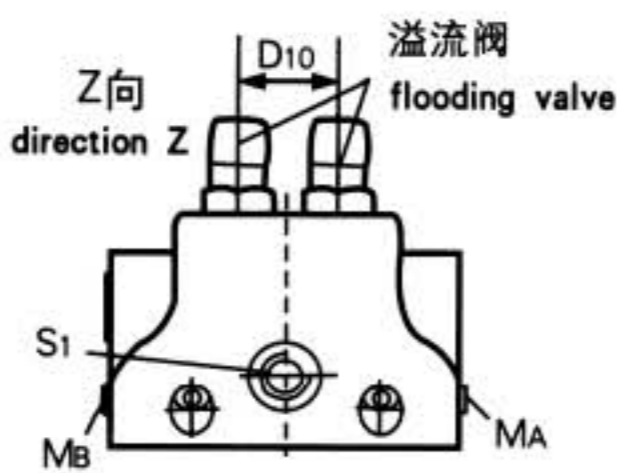
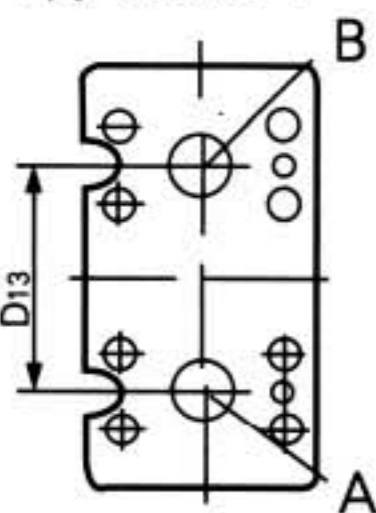

油口接板 port plates 191

(单级溢流阀 single level flooding valve)

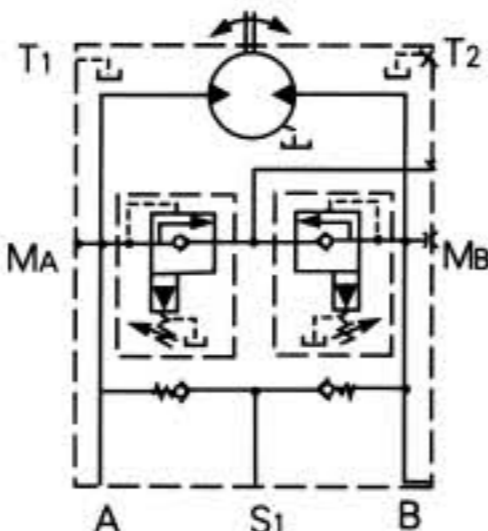

油口接板 port plates 192

(两级溢流阀 two level flooding valve)

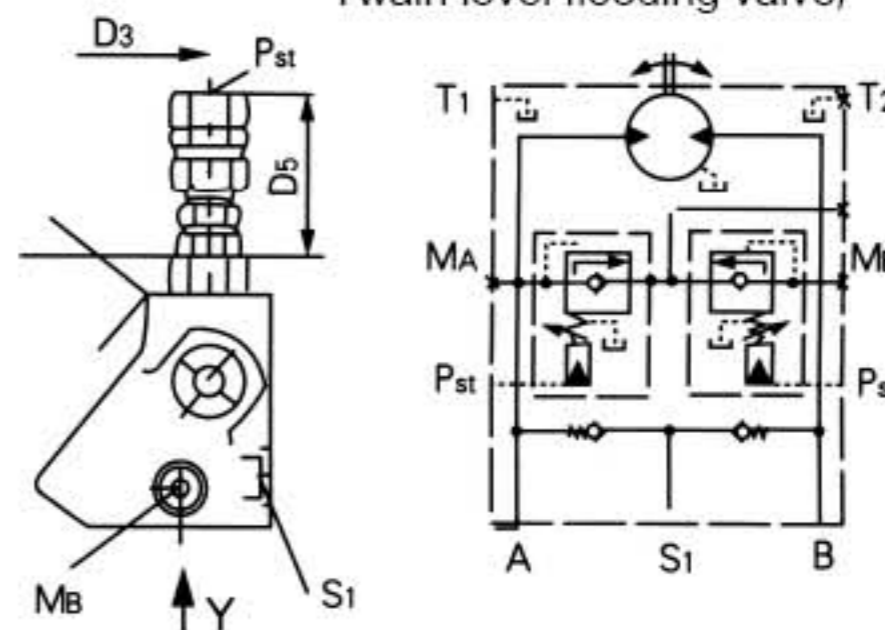

油口 connections

A, B 工作油口 service port SAE, 420bar (见下表 see below table) (6000 psi) 高压系列 high pressure series
 S1 升压口 (pressure line) (见下表 see below table)
 Pst 先导压力口 (pilot pressure) G 1 / 4
 MA, MB 测试 (已被塞住) M12 x 1.5 test line (be stuffed)

溢流阀 flooding valve

单级 single level (1) 两级 two level (2)
 MHDBN16 (规格 size 28...45) MHDBB16 (规格 size 28...45)
 MHDBN22 (规格 size 56...90) MHDBB16 (规格 size 56...90)
 MHDBN32 (规格 size 107...180) MHDBB16 (规格 size 107...180)

规格 Size	D1	D2	D3	D4	D5	D6	D7	D8	D9	D10	D11	D12	D13	油口 port A,B	油口 port S	油口 port S1
28,32	145	170	127	25	63	110	102	115	87	36	215.5	93.5	66	SAE3/4"	M18 x 1.5	M18 x 1.5
45	161	181	136	22	60	126	113	115	98	36	215.5	93.5	66	SAE3/4"	M18 x 1.5	M18 x 1.5
56,63 (+MHB16)	189	192	162	19	57	147	124	115	105	42	215.5	93.5	75	SAE3/4"	M18 x 1.5	M22 x 1.5
(+MHB20)	189	192	162	29	57	147	124	137	105	42	235	96	75	SAE3/4"	M22 x 1.5	M22 x 1.5
80,90	193	202	165	17.5	55	151	134	137	114	42	235	96	75	SAE1"	M22 x 1.5	M22 x 1.5
107,125 (+MHB20)	216	217.5	184	10	48	168	149.5	137	130	53	286	120.5	84	SAE14"	M27 x 2	M22 x 1.5
(+MHB25)	216	234.5	184	10	48	168	149.5	151.5	130	53	286	120.5	84	SAE1 1/4"	M27 x 2	M22 x 1.5
160,180	253	255	222	5	-	204	170	151.5	-	53	286	120.5	84	SAE1 1/4"	M27 x 2	-