

BEIJING HUADE HYDRAULIC INDUSTRIAL GROUP CO.,LTD.	<b>Pilot operated Check valve sandwich plate Type Z2S (New Series)</b>			RE 21601/12.2004
	Size 6、10 16、22	up to 31.5 MPa	up to 450L/min	

**Features:**

- For use in vertical stacking assemblies
- For the leak free closure of one or two service ports
- Porting pattern to Din 24 340 form A, ISO 4401 and CETOP-RP 121H



**Functional, section**

Hydraulic pilot operated check valves type Z2S are of sandwich plate design.

They are used for the leak-free closure of one or two service ports, even for long periods.

Free flow occurs from A1 to A2 or B1 to B2, the opposite direction is blocked.

When fluid flows from A1 to A2, the pressure is pushed to the right opening the ball poppet valve (2) with the poppet (3).

In order to ensure correct closing of service ports of the directional valve connected to tank in the neutral position.

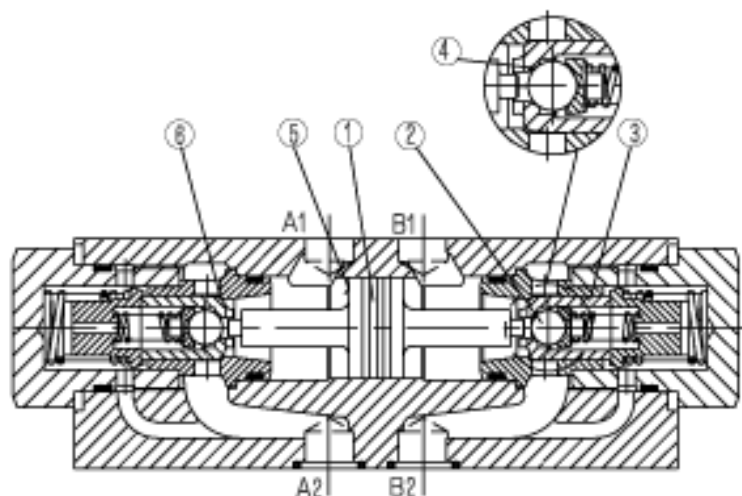
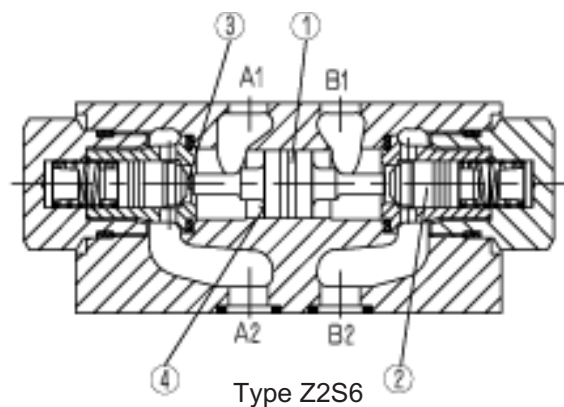

- 1 Spool
- 2 Ball poppet valve
- 3 Poppet
- 4 Area A1
- 5 Area A2
- 6 Area A3

Type Z2S10

## Typical circuit example

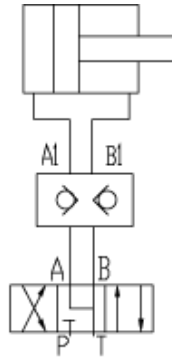

## Symbols

Z2S.../

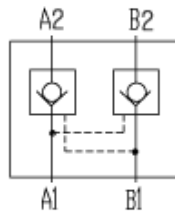

Z2S...A.../

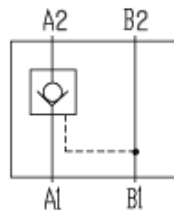

Z2S...B.../

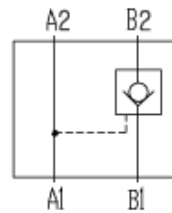

## Ordering details



Size6	= 6
Size10	= 10
Size16	= 16
Size22	= 22

Further details in clear text

No code = Mineral oils  
V = Phosphate ester

B =The technology of Beijing Huade Hydraulic

30 = Series 30 to 39 (Apply to size 10)  
(30 to 39: unchanged installation and connection dimensions)  
50 = Series 50 to 59 (Apply to size 16,22)  
(50 to 59: unchanged installation and connection dimensions)  
60 = Series 60 to 69 (Apply to size 6)  
(60 to 69: unchanged installation and connection dimensions)

Leak free closure of ports A and B

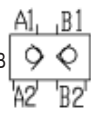

= No code

Leak free closure of port A

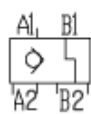

= A

Leak free closure of port B

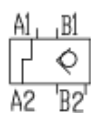

= B

- 1 = Cracking pressure 0.15MPa (only for size6、10)  
Cracking pressure 0.3MPa (only for size16、22)
- 2 = Cracking pressure 0.3MPa  
Cracking pressure 0.5MPa (only for size 16,22)
- 3 = Cracking pressure 0.6MPa (only for size10)  
Cracking pressure 0.7MPa (only for 6)  
Cracking pressure 0.75MPa (only for 16、22)
- 4 = Cracking pressure 1.0MPa (only for 10、16、22)

## Technical data

Size		6	10	16	22
Max. flow L/min	(L/min)	to 60	to 120	to 300	to 450
Max. operating pressure	(MPa)	31.5			
Cracking pressure	(MPa)	see curve			
Directions		see symbols			
Area ratio		A1/A2=1:3	A1/A2=1:11.45	A1/A2=1:11.8	A1/A2=1:13.6
			A3/A2=1:2.86	A3/A2=1:2.8	A3/A2=1:2.8
Pressure fluid		Mineral oils(for NBR seal) or phosphate ester(for FPM seal)			
Pressure fluid temperature range	(°C)	-30 to +80			
Viscosity range	(mm <sup>2</sup> /s)	2.8 to 500			
Weight	(kg)	approx. 0.8	approx. 3	approx. 6.5	approx. 12

## Characteristic curves (measured at $\nu = 41 \text{ mm}^2/\text{s}$ and $t = 50 \text{ }^\circ\text{C}$ )

### Type Z2S6

— = A1 → A2; B1 → B2  
 - - - = A2 → A1; B2 → B1

- 1、Cracking pressure 1=0.15MPa
- 2、Cracking pressure 2=0.3MPa
- 3、Cracking pressure 3=0.7MPa
- 4、Through check valve cartridge
- 5、Flow freely  
 (Without check valve cartridge type "A" and type "B")

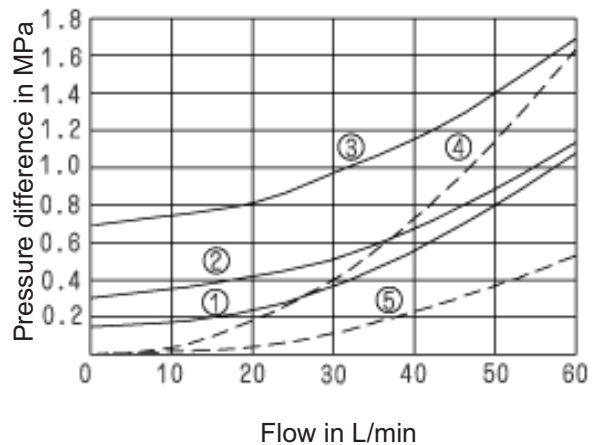

### Type Z2S10

— = A1 → A2; B1 → B2  
 - - - = A2 → A1; B2 → B1

- 1、Cracking pressure 1=0.15MPa
- 2、Cracking pressure 2=0.3MPa
- 3、Cracking pressure 3=0.6MPa
- 4、Cracking pressure 4=1.0MPa

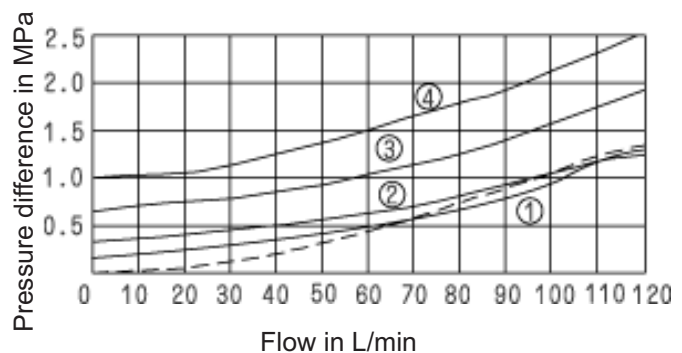

### Type Z2S16

— = A1 → A2; B1 → B2  
 - - - = A2 → A1; B2 → B1

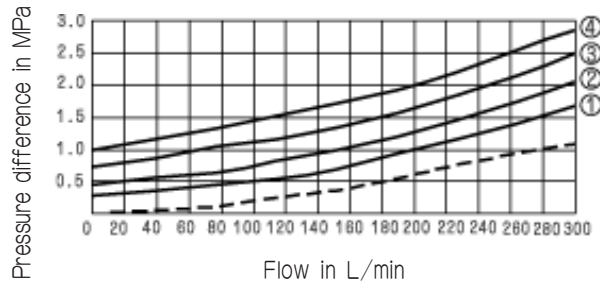

### Type Z2S22

— = A1 → A2; B1 → B2  
 - - - = A2 → A1; B2 → B1

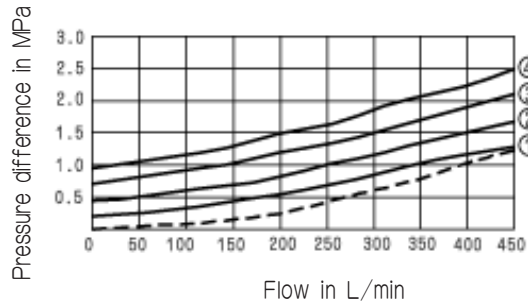

### Unit dimensions

(Dimensions in mm)

#### Size6

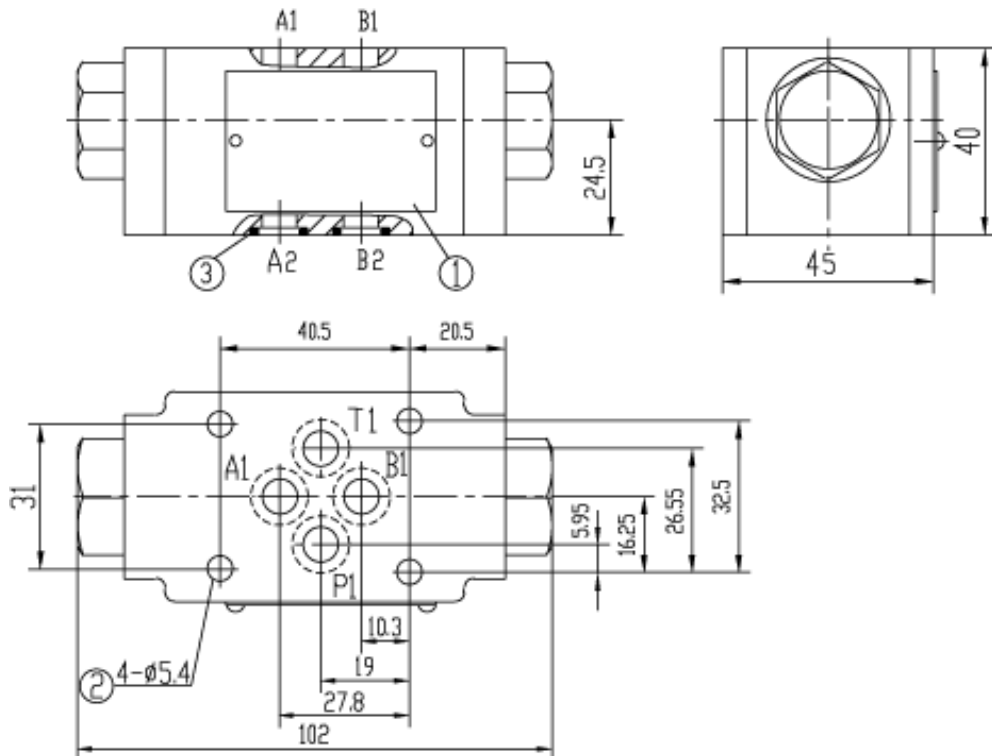

1. Name plate
2. Holes for mounting
3. O-rings 9.25 x 1.78 for four ports  
 Valve fixing screws 4 - M5 -10.9  
 (GB/T70.1-2000)  
 Screw torque:  $M_A = 8.9 \text{ Nm}$

**Unit dimensions**

**(Dimensions in mm)**

Size10

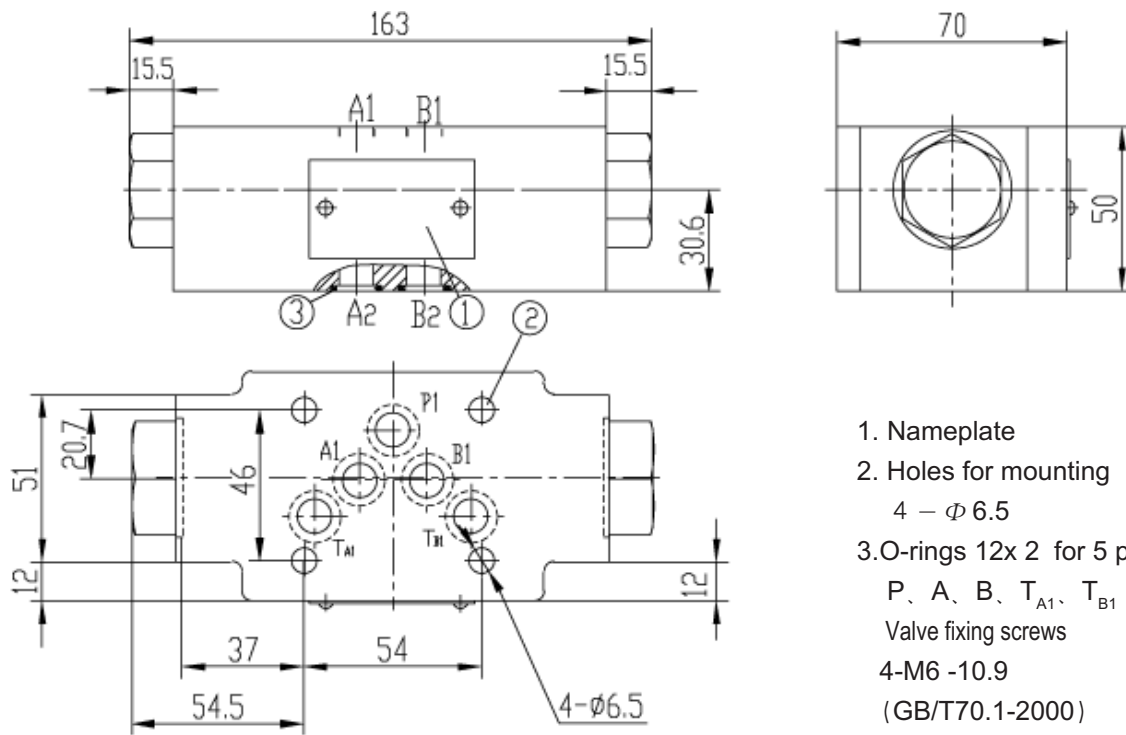

1. Nameplate
2. Holes for mounting  
4 -  $\phi$  6.5
3. O-rings 12x 2 for 5 ports  
P、A、B、 $T_{A1}$ 、 $T_{B1}$   
Valve fixing screws  
4-M6 -10.9  
(GB/T70.1-2000)  
Screw torque:  $M_A=15.5\text{Nm}$

Size16

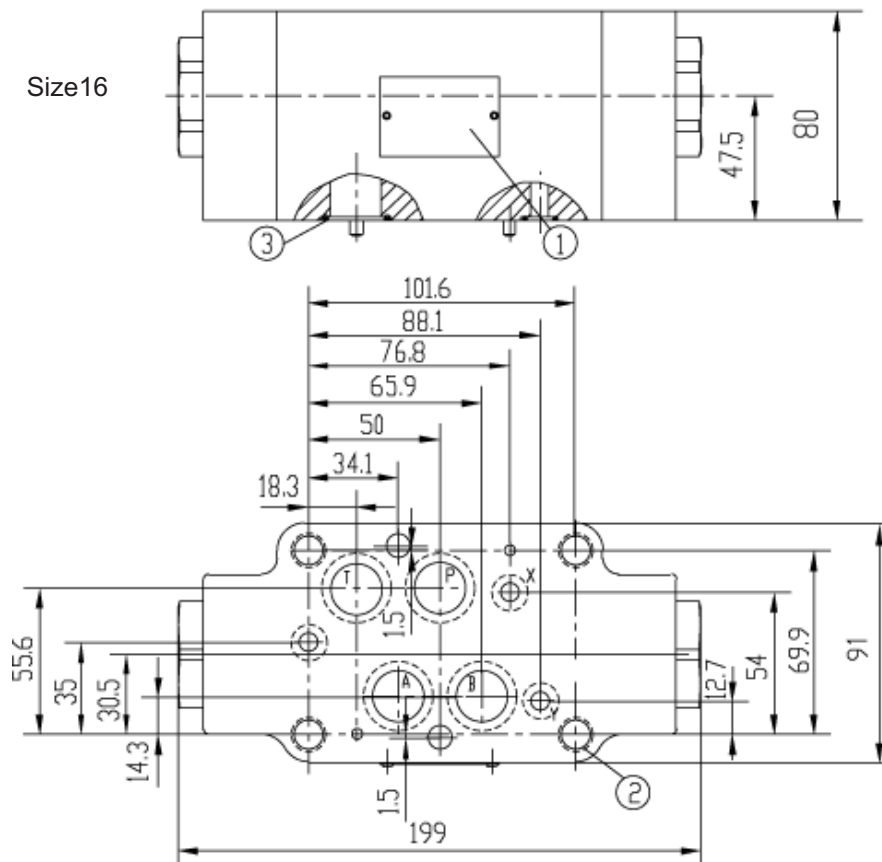

1. Nameplate
2. Holes for mounting  
10X2 for ports X、Y、L  
Valve fixing screws:  
① 4-M10 -10.9  
(GB/T70.1-2000)  
Screw torque:  $M_A=75\text{Nm}$   
② 2-M6 -10.9  
(GB/T70.1-2000)  
Screw torque:  $M_A=15.5\text{Nm}$
3. O-rings 22x 2.5 for ports  
P、A、B、T

Size22

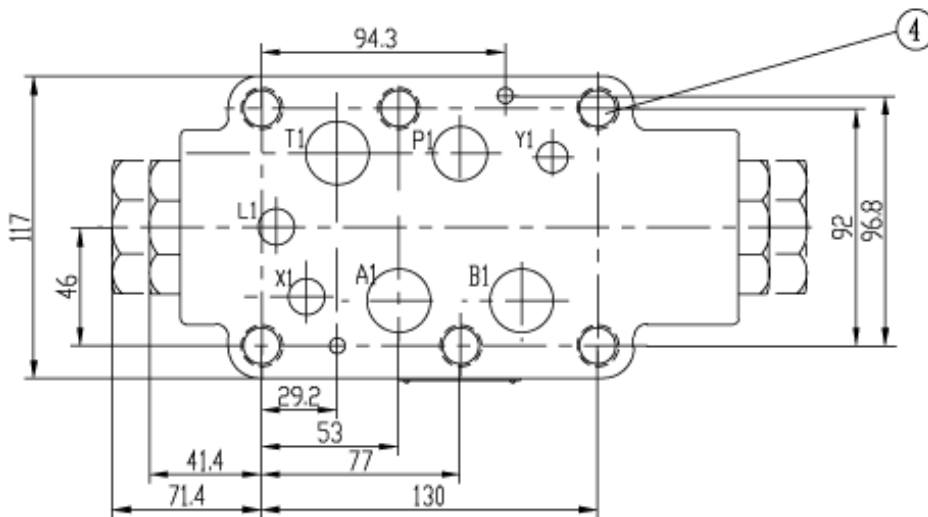
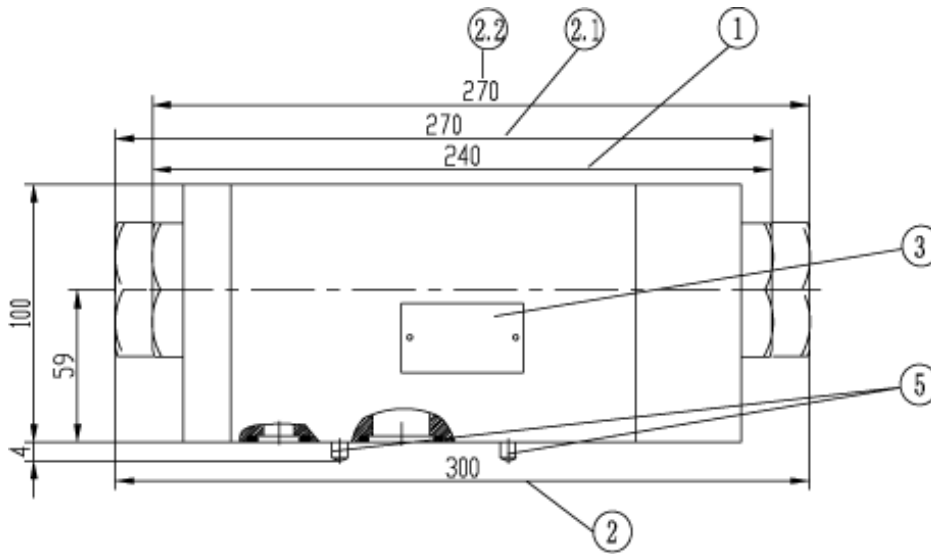

- 1 Cracking pressure 0.3MPa or 0.5MPa , Leak free closure of ports A and B
- 2 Cracking pressure 0.75MPa or 1.0MPa , Leak free closure of ports A and B
- 2.1 Cracking pressure 0.75MPa or 1.0MPa , Leak free closure of port A
- 2.2 Cracking pressure 0.75MPa or 1.0MPa , Leak free closure of port B
- 3 Label plate
- 4 Valve fixing screws:  
6- M14-10.9 (GB/T70.1-2000),  
Screw torque: $M_A=205\text{Nm}$
- 5 Fixing pin

Required surface finish of mating piece

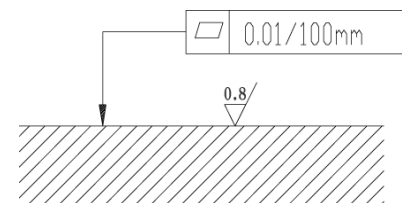

## Notice

1. The fluid must be filtered. Minimum filter fineness is 20  $\mu\text{m}$ .
2. The tank must be sealed up and an air breather/filter must be installed on air suction/entrance.
3. Subplate are not supplied, if required, please ordering separately.
4. Valve fixing bolts/screws must be high tensile (class 10.9). Please select and consult manufacturer according to the parameter listed in the datasheet.
5. Roughness of surface mating with the valve is required to  $\sqrt{0.8}$  .
6. Surface straightness of mating piece is required to 0.01/100mm.

All rights reserved-Subject to revision

### **THM Huade Hydraulics (P) Ltd**

F-127, Focal Point, Phase VIII

Ludhiana-141010, India

Phone: 0091+161+2672777, Fax: 0091+161+2672778

[www.thmhuade.com](http://www.thmhuade.com)

[info@thmhuade.com](mailto:info@thmhuade.com), [sales@thmhuade.com](mailto:sales@thmhuade.com)