

BMV

Orbital Hydraulic Motor
Sizes: 315 to 1000cc/rev
Max. Pressure up 200Bar

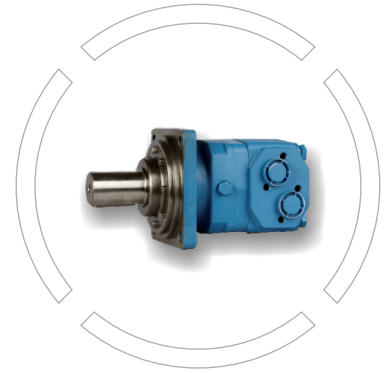

Index

Page No

• Introduction	02
• Performance data	03
• BMV Dimensions and Mounting data	05
• Shaft Extensions for BMTE Motors	06
• BMV Series Hydraulic Motor	07
• Ordering Code	08



Introduction

- BMV series motor adapt the advanced Geroler gear set designed with disc distribution flow and high pressure. The unit can be supplied the individual variant in operating multifunction in accordance with requirement of applications.
- Characteristic features:
 - Advanced manufacturing devices for the Geroler gear set, which use low pressure of start-up, provide smooth and reliable operation and high efficiency.
 - The output shaft adapts in tapered roller bearings that permit high axial and radial forces. The case can offer capacities of high pressure and high torque in the wide of applications.
 - Advanced design in disc distribution flow, which can automatically compensate in operating with high volume efficiency and long life, provide smooth and reliable operation.
- Main Specifications:

Type		BMV 315	BMV 400	BMV 500	BMV 630	BMV 800	BMV 1000
Geometric Displacement (cm ³ /rev.)		333	419	518	666	801	990
Max Speed (rpm)	cont.	510	500	400	320	250	200
	int.	630	600	480	380	300	240
Max torque (N•m)	cont.	920	1180	1460	1660	1880	2015
	int.	1110	1410	1760	1940	2110	2280
	peak	1290	1640	2050	2210	2470	2400
Max Output (KW)	cont.	38.0	47.0	47.0	40.0	33.0	28.6
	int.	46.0	56.0	56.0	56.0	44.0	40.0
Max Pressure drop (MPa)	cont.	20	20	20	18	16	14
	int.	24	24	24	21	18	16
	peak	28	28	28	24	21	18
Max. flow (L/min.)	cont.	160	200	200	200	200	200
	int.	200	240	240	240	240	240
Weight (Kg)		31.8	32.6	33.5	34.9	36.5	38.6

- Continuous pressure :Max. value of operating motor continuously.
- Intermittent pressure :Max. value of operating motor in 6 seconds per minute.
- Peak pressure: Max. value of operating motor in 0.6 second per minute.



Performance Data

BMV 315 [333cm³/rev.]

Pressure (MPa) Max.cont. Max.int.

	3.5	7	10	14	18	20	24		
Flow (L/min)	10	140	294	440	610	742	845	1000	
		26	24	23	22	20	17	14	
	20	153	314	466	636	787	895	1070	
		55	54	53	52	51	48	44	
	50	149	312	465	654	815	935	1112	
		145	144	142	140	137	133	127	
	75	143	304	458	642	816	940	1119	
		220	218	215	211	207	202	195	
	100	136	297	452	636	810	936	1108	
		294	292	290	287	283	278	270	
Max.cont.	125	123	286	442	626	799	921	1093	
		368	366	364	361	357	352	345	
	150	114	275	435	615	788	906	1078	
		445	443	441	437	430	422	410	
	160	107	268	430	608	780	895	1070	
		475	473	470	466	460	452	439	
	Max.int.	200	82	249	412	593	758	871	1047
			596	594	590	584	576	565	544

BMV 400 [419cm³/rev.]

Pressure (MPa) Max.cont. Max.int.

	3.5	7	10	14	18	20	24		
Flow (L/min)	10	183	385	568	776	968	1101	1292	
		20	20	19	18	17	16	14	
	20	196	398	590	815	1010	1152	1346	
		44	44	43	42	40	39	37	
	50	200	402	603	842	1040	1186	1430	
		114	113	113	112	110	108	103	
	75	195	394	596	838	1043	1188	1432	
		175	173	170	166	163	157	152	
	100	172	385	593	827	1036	1184	1425	
		236	235	233	231	227	223	215	
Max.cont.	125	167	374	583	816	1021	1177	1413	
		296	294	291	288	282	275	268	
	150	158	361	559	801	1008	1165	1390	
		355	354	352	349	344	335	324	
	175	143	346	553	784	989	1145	1377	
		416	414	411	407	403	396	388	
	Max.int.	200	118	331	536	770	969	1128	1356
			475	473	469	463	455	448	439
		82	301	506	740	943	1104	1332	
		571	569	565	548	539	530	520	

BMV 500 [518cm³/rev.]

Pressure (MPa) Max.cont. Max.int.

	3.5	7	10	14	18	20	24		
Flow (L/min)	10	242	468	696	959	1190	1353	1607	
		17	17	16	16	15	13	11	
	20	245	501	738	1003	1232	1394	1658	
		36	35	35	34	33	32	29	
	50	240	500	758	1025	1270	1449	1743	
		93	92	91	90	88	85	80	
	75	233	498	752	1030	1288	1475	1766	
		140	139	137	135	132	127	120	
	100	228	491	748	1026	1289	1472	1760	
		189	187	185	182	178	173	166	
Max.cont.	125	220	483	742	1014	1280	1460	1745	
		237	236	234	231	227	223	216	
	150	201	465	723	1008	1250	1429	1736	
		287	286	284	281	276	270	260	
	175	182	446	711	997	1238	1406	1715	
		335	334	332	329	325	320	310	
	Max.int.	200	161	423	676	974	1218	1385	1697
			384	383	381	378	374	366	354
		120	378	622	921	1172	1340	1650	
		461	459	457	454	450	444	432	

BMV 630 [666cm³/rev.]

Pressure (MPa) Max.cont. Max.int.

	3.5	6	9	12	15	18	21		
Flow (L/min)	10	280	522	812	1100	1268	1549	1784	
		14	13	13	12	12	11	10	
	20	288	552	839	1101	1315	1607	1864	
		28	28	27	27	26	24	22	
	50	289	555	868	1137	1364	1682	1956	
		72	72	71	69	68	66	62	
	75	270	548	863	1120	1352	1680	1964	
		109	108	106	104	102	99	94	
	100	264	538	856	1093	1350	1674	1965	
		146	145	143	141	138	135	130	
Max.cont.	125	251	516	837	1071	1336	1659	1950	
		184	183	181	179	177	173	168	
	150	240	495	817	1063	1330	1650	1928	
		221	220	219	217	215	212	205	
	175	210	485	796	1052	1300	1636	1908	
		259	258	257	254	250	246	241	
	Max.int.	200	182	469	751	1018	1280	1611	1883
			297	297	295	293	290	284	273
		130	416	712	978	1237	1563	1835	
		358	357	355	351	346	340	332	

Torque (N•m) 1340
Speed (rpm) **444**

□ cont.
■ int.



Performance Data

BMV 800 [801cm³/rev.]

Pressure (MPa)		Max.cont.		Max.int.		
2.5	5	8	10	13	16	18

Flow (L/min)	Pressure (MPa)						
	2.5	5	8	10	13	16	18
10	278 11	565 10	830 10	1095 9	1405 8	1712 8	1915 7
20	282 23	571 22	845 22	1150 21	1456 20	1783 18	1994 16
50	288 60	582 59	856 57	1162 56	1463 54	1790 52	2001 48
75	269 91	580 90	855 89	1165 87	1465 84	1786 81	1993 77
100	251 122	566 121	840 120	1140 118	1448 115	1767 111	1985 105
125	242 153	535 152	824 150	1118 147	1427 143	1739 139	1976 133
150	236 185	526 183	808 181	1102 178	1401 174	1714 169	1959 163
175	215 216	504 214	793 212	1079 209	1377 206	1698 203	1936 196
Max.cont. 200	197 247	468 245	765 243	1063 240	1362 237	1681 232	1913 225
Max.int. 240	118 297	388 296	713 295	1020 293	1318 288	1637 283	1838 277

cont.
 int.

BMV 1000 [990cm³/rev.]

Pressure (MPa)		Max.cont.		Max.int.	
2.5	5	7	10	14	16

Flow (L/min)	Pressure (MPa)					
	2.5	5	7	10	14	16
10	312 9	640 9	971 9	1400 8	1978 7	2259 6
20	320 28	648 27	978 26	1410 25	1980 23	2270 21
50	326 47	655 46	992 45	1422 43	2015 41	2280 38
75	318 72	642 71	987 70	1425 68	2003 66	2276 63
100	309 98	634 97	983 95	1418 93	1994 90	2243 86
125	303 123	624 122	975 120	1409 117	1988 114	2224 110
150	278 149	602 148	961 146	1368 144	1963 140	2208 133
175	264 174	580 172	946 170	1338 166	1925 162	2159 155
Max.cont. 200	230 199	556 196	912 193	1300 190	1891 185	2105 178
Max.int. 240	166 240	513 237	867 233	1267 229	1825 225	2034 218

Torque (N•m) 1825
 Speed (rpm) **225**



BMV Dimensions and Mounting Data

Model	L	L1	L2
BMV315	217	20	161.5
BMV400	224	27	168.5
BMV500	232	35	176.5
BMV630	244	47	188.5
BMV800	255	58	199.5
BMV1000	271	74	215.5

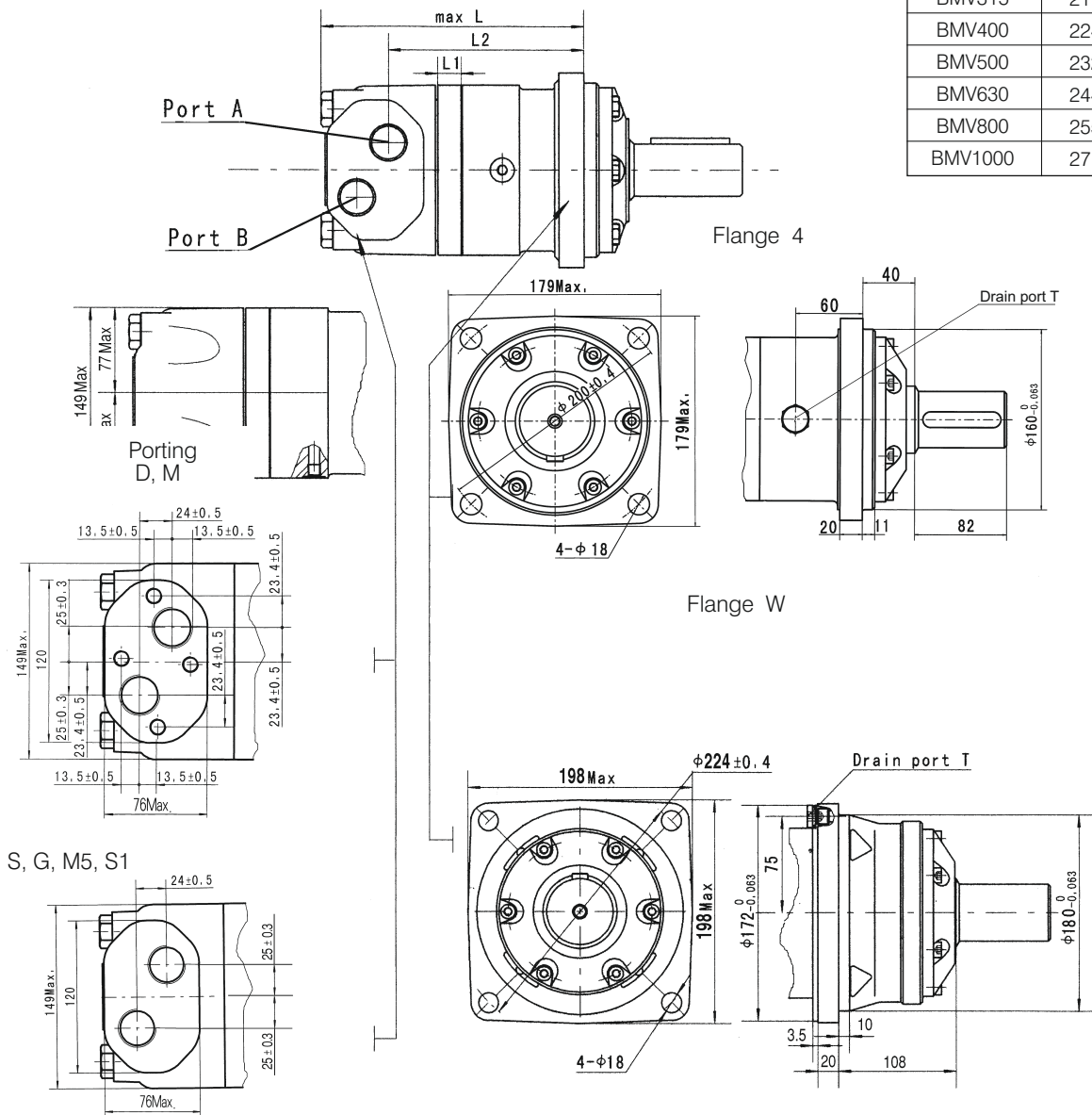

Model	L	L1	L2
BMVW315	148.5	20	93.5
BMVW400	155.5	27	100.5
BMVW500	163.5	35	108.5
BMVW630	175.5	47	120.5
BMVW800	186.5	58	131.5
BMVW1000	202.5	74	147.5

Note: The thickness of the stator and rotor is the dimension of L1 adding on 7mm.

Content	Code					
	D (depth)	M (depth)	S (depth)	G (depth)	M5 (depth)	S1 (depth)
P(A,B)	G1 (18)	M33 x 2 (18)	1-5/16-12UN(18)	G1 (18)	M33 x 2 (18)	1-5/16-12UN(18)
T	G1/4 (12)	M14 x 1.5 (12)	9/16-18UNF(12)	G1/4 (12)	M14 x 1.5 (12)	7/16-20UNF(12)
C	4-M12 (10)	4-M12 (10)	--	--	--	--



BMV Shaft Extensions Mounting Data

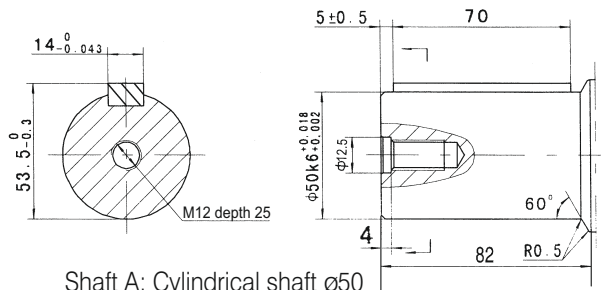

Shaft A: Cylindrical shaft $\varnothing 50$
Parallel key 14x9x70

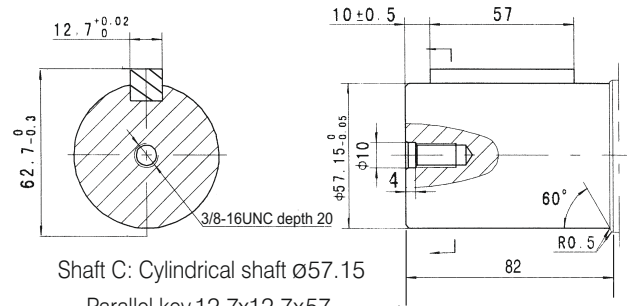

Shaft C: Cylindrical shaft $\varnothing 57.15$
Parallel key 12.7x12.7x57

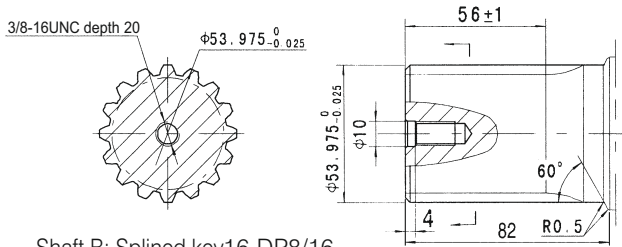

Shaft B: Splined key 16-DP8/16

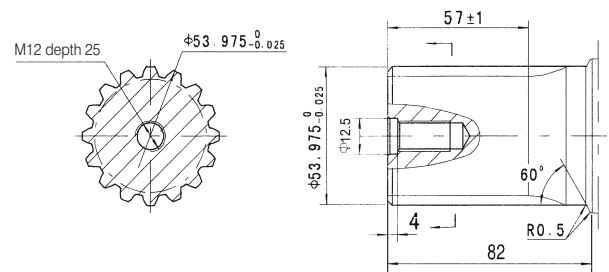

Shaft BD: Splined key 16-DP8/16

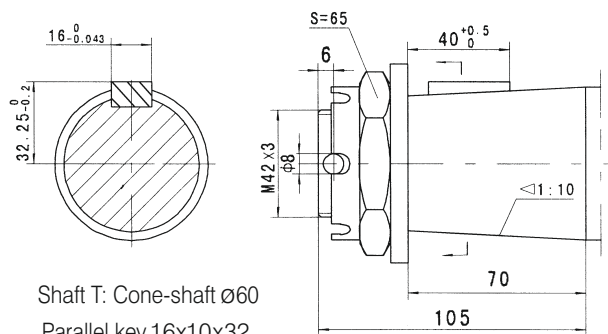

Shaft T: Cone-shaft $\varnothing 60$
Parallel key 16x10x32
Tightening torque: 750 ± 50 Nm

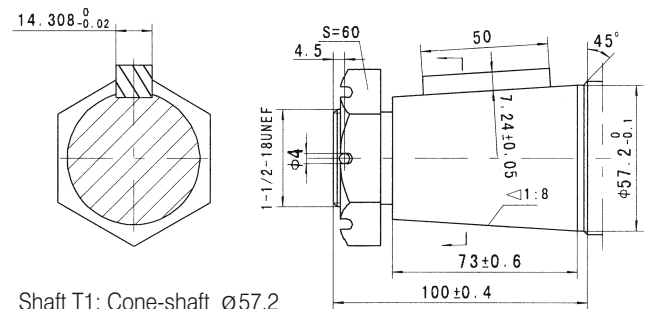

Shaft T1: Cone-shaft $\varnothing 57.2$
Parallel key 14.308x14.308x50
Tightening torque: 750 ± 50 Nm



BMV Series Hydraulic Motor

- Permissible shaft seal pressure

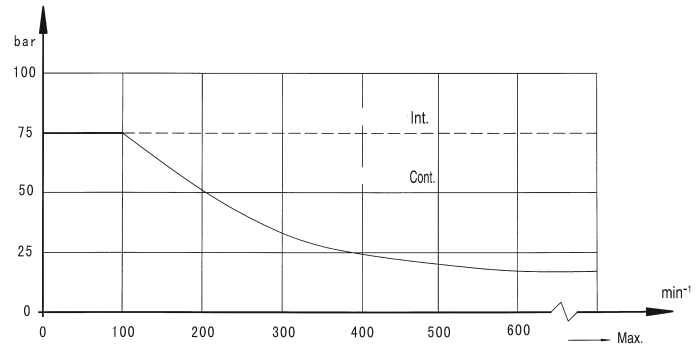
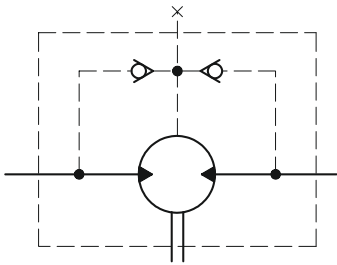

- Standard direction of shaft rotation: Standard

When facing shaft end of motor, shaft to rotate:
 Clockwise when port "A" is pressurized.
 Counter-clockwise port "B" is pressurized.

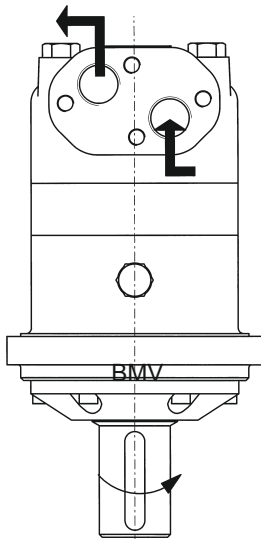

In applications without drain line, output shaft seal exceeds a bit of the pressure in the return line. When applications use the drain line, the pressure of output shaft seal equals the pressure in drain line.

- Oil flow in drain line

The table shows the Max. oil flow in the drain line at a return pressure less than 0.5-1MPa.

Pressure drop (Mpa)	Viscosity (mm ² /s)	Oil flow in the drain line (L/min.)
14	20	3
	35	2
21	20	6
	35	4

Axial and Radial forces

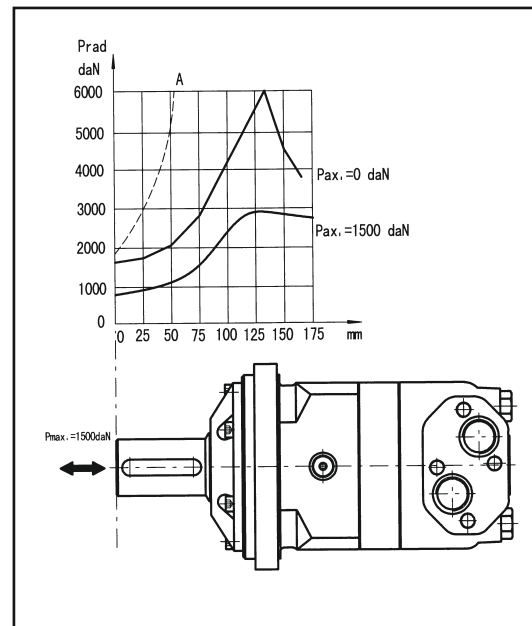

The output shaft runs in tapered bearings that permit high axial and radial forces, Curve "A" shows max radial shaft load, Any shaft loads exceeding the values quoted in the curve will involve a risk of breakage, The two other curves apply to a B10 bearing life of 3000 hours at 200 RPM.



Ordering Code

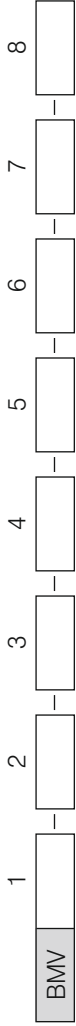

Pos.1	2	3	4	5	6	7	8
Code	Displacement	Flange	Output shaft	Ports and drain port	Rotation direction	Paint	Unusually function
Omit	315	4-Ø18 Square-flange Ø200, pilot Ø160×11 4-Ø18 Wheel-flange Ø224, pilot Ø180×10	A Shaft Ø50 , parallel key 14×9×70	D G1 Manifold 4×M12, G1/4	Omit Standard R Opposite	00 Blue Black Silver grey	Standard
	400		BD Shaft Ø53.975, splined key 16-DP8/16	M M33×2 Manifold 4×M12, M14×1.5			
	500		B Shaft Ø53.975, splined key 16-DP8/16	S G1, G1/4			
	630		C Shaft Ø57.15, parallel key 12.7×12.7×57.15	G M33×2, M14×1.5			
	800		T Cone shaft Ø60, parallel key 16×10×32	M5 1-5/16-12UN			
	1000		T1 Cone shaft Ø57.2, parallel key 14.308×14.308×50.8	S1 7/16-20UNF			

Note: When the table is used, please fill the code of left rows in dash area and give us, which the code information is consists of construction, displacement, mounting flange, output shaft and ports. If the specification is not in the table or you have specific requirements, please contact us.

