



THM
HYDRAULICS

HYDRAULIC CONTROL SYSTEM

PROPORTIONAL DIRECTIONAL SPOOL VALVE

Index

Page No

• TSL/V-2 Proportional directional spool valves type size2	01-14
• TSL/V-3 Proportional directional spool valves type series 3	15-41
• TSL/V-5 Proportional directional spool valves type serie 5	42-58
• TSL/V-CAN Explosion-proof CAN bus control type &CAN bus control type proportional directional spool valves	59-64
• VB0124 Electronically controlled Proportional directional spool valves	65-66
• PA222 Proportional amplifier	67-71

TSL/V-2

Proportional directional spool valves type size2
 Pmax = 420bar
 Qmax = 60lpm

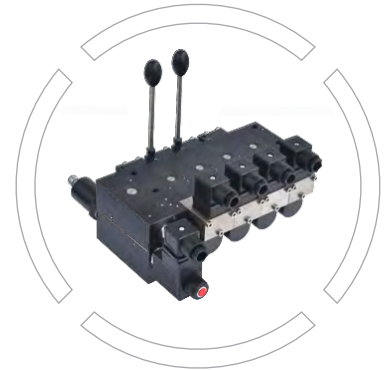

Index

Page No

• Product overview	01
• Ordering code description	03-05
• Valve hydraulic circuit	06-07
• Spool valves hydraulic circuit	08
• Unit Dimension	09-10
• End plate hydraulic circuit	11-12
• Proportional directional spool valve characteristic curve	13-14

Product overview

Load-sensing Proportional directional spool valves types series 3 can be used in constant displacement pump and variable displacement pump hydraulic system. Stepless speed regulation can be carried out on the cylinder or motor by means of electronic control manual and hydraulic control.

The output flow is only proportional to the input current signal or handle lever, and the speed is independent of the load, so several actuators can work at different pressure and speed independently until the total required flow rate of the actuator is greater than the maximum flow rate that the pump can provide.

The valve contains three functional blocks: connection block, directional valves and end plate.

Each function block has different functions for option.

Maximum of 12 sections in each bank of valve.



Ordering code

TSL 3 G 1 Z / 280 - 2 - A 1 J 40/25 /EA/2
 - A 2 O 16/10 A200 B300 S / EA /2 AS200 BS250 -E3-G12

1 2 3 4 5 6 7 8 9 10 11 12 13 14 15 16 17

① **TS - THM Huade Hydraulics Pvt Ltd**

② **Connection block type**

Type TSL Connection block with integrated 3-way controller for Supply with pressurized oil by means of constant delivery pump (open center)

Type TSV Supply with pressurized oil by means of displacement pump (closed center)

Type ZPL32 Transition adapter plate for combination of 3 size and 2 size directional spool valves.

Type ZPL52 Transition adapter plate for combination of 5 size and 3 size directional spool valves.

③ **Thread size of P and R ports** DIN ISO 228/1 (BSPP) standard,

3 G1/2 Max inlet flow 80 lpm

④ **LS damping elements**

No code Basic version

The TSL connecting block is a damping element integrated with a check valve, an orifice, and a back pressure valve
 TSV connecting block is a screw plug, which has no damping effect on LS oil circuit

Coding S,W Damping element integrated with check valve, orifice and back pressure valve. S type is only used for TSV type connection block, as TSL standard type; W type is like S type, but it has enhanced throttling effect (W type is not applicable to PSL4K and PSL4Z)

Coding G Damping element integrated with check valve and orifice, without back pressure valve, makes LS oil circuit have strong damping during system pressure relief, which is conducive to system stability

Coding B Only increase throttling damping in LS oil circuit of TSV, B (standard orifice diameter is $\phi 0.8\text{mm}$), B4 ($\phi 0.4\text{mm}$), B5 ($\phi 0.5\text{mm}$), B6 ($\phi 0.6\text{mm}$), B7 ($\phi 0.7\text{mm}$).

Coding Z,K One way throttle valve unloading valve(TSL)

Coding H The integrated 3-way controller increases the circulating pressure of the pump (about 14bar, TSL type), which is the same as the standard type in other aspects.

Coding U,UH Automatically reduce the unloading circulating pressure of the pump with the help of the bypass valve

⑤ **Pilot control oil supply**

No code No 3-way pressure reducing valve; manual operated valves do not need pilot control oil, or pilot control pressure reducing valve (pressure range 20~40 bar, flow rate approx. 2 lpm)

1 With 3-way pressure reducing valve, output pressure approx. 20 bar, standard type

2 With 3-way pressure reducing valve, output pressure approx. 40 bar

⑥ **Solenoid Valve for pump unloading**

NO coding No solenoid valve, but the installation position is reserved, can be installed at any time

Coding Z Normally open solenoid valve. When the valve loses power, the pump unloads, that is, the multi way valve is in standby state.

Coding V Normally closed solenoid valve. When the valve is powered on, the pump unloads, that is, the multi way valve is in standby state.



Ordering code

- ⑦ **Relief valve pressure setting on the connection block**
/... Pressure at port P is limited to... bar, and the regulating range is 50-420bar
- ⑧ **Size**
Type 2 series 2
- ⑨ **Tape of directional spool valve**
Type A1 The directional spool valve without two-way flow control valve cannot be installed with LS relief valve, which is used for the working condition without simultaneous combined action of multiple reversing block
Type A2 The directional spool valve with two-way flow control valve has a control pressure differential of about 6 bar and additional functions such as pressure limitation at A/B port and flow cut-off at A/B port for load pressure compensation of simultaneous movement of several actuating elements
Type 42 2-way flow control valve equipped with inlet and outlet is only applicable to three position three-way reversing valve. There is only one output port, and the valve element can only use N type
Type A5,A7 The reversing block with two-way flow control valve can increase the output flow of the directional spool valves by increasing the spring control differential pressure. It can only be used with TSL... H/... 2 type connection block or TSV type connection block. See the flow table on page ⑪ for the increased flow.
Type A8 The preselected switching valve is used to switch the oil circuit of the upper and lower vehicles, so that the upper and lower vehicles can not act at the same time, improving the safety and reliability of operation
- ⑩ **Spool function**

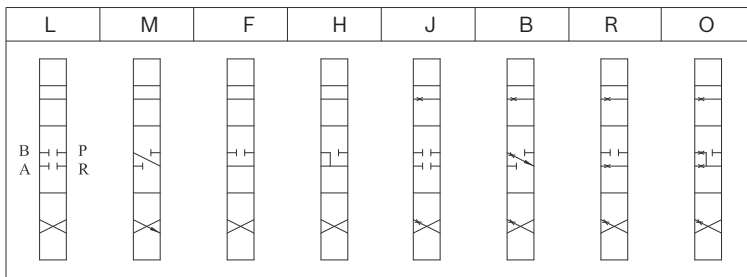

Under the working conditions that may cause system vibration (such as working wall amplitude variation or expansion jitter), especially when Proportional directional spool valve and balance valve are used together, it is recommended to select the valve core with oil return throttling back pressure function, wherein the back pressure value of the valve core with J, B, R and O functions is about 20bar in the full stroke. The maximum back pressure of the valve core with L, M, F and H functions in the full stroke is about 10bar.

- ⑪ **Rated flow of port A/.../...** Rated flow values for ports A and B

type of directional valve section block	Type of connection block	Rated flow of A/B port					
		3	6	10	16	25	40
2	TSL or TSV	3	6	10	16	25	40
	TSL	4	9	14	22	34	54
1	TSV	$Q_{AB} = Q_{Ostandard} \times \sqrt{0.2 \times \Delta P_{con}}$					
5	TSL.H. or TSV	4	9	15	22	34	54
7	TSL.H. or TSV	5	10	14	24	38	60
8	TSL or TSV	For A-bit flow, see code 1, and B-bit flow should be set to 40					

Q_{AB} ---Maximum output flow of directional spool valves A/B port
 $Q_{standard}$ ---Standard flow of directional spool valves with 2-way flow controller valve
 $P_{con}^{standard}$ ---Control differential pressure

Note: The flow of the selected A/B port cannot be much larger than the actual demand flow, otherwise, if the maximum flow of A, B port is limited by using the spool travel limit screw in the actual use process, the flow linear control curve of the directional spool valves will be directly shortened, reducing the proportional control performance of the directional spool valve. Therefore, it is recommended that the flow selected by the user is about 1.2 times of the actual demand flow, which not only leaves a certain margin for design and commissioning, but also gives better play to the proportional control performance of the directional spool valve.



Ordering code

Note: When the TSV type proportional directional spool valves with the basic type of the directional spool valves as 1 (the directional spool valves does not have a 2-way flow controller valve) is used together with the load sensitive variable pump, the output flow of the reversing block depends on the pressure setting value of the "pressure flow control valve" of the load sensitive variable pump. From the flow formula, the greater the pressure difference, the greater the flow, and the flow value is calculated from the flow formula in the table

12 A/B port pressure limit

(only for blocks with 2-way flow control valves, not used with buffer valves)

No code There is no limit pressure at port A/B, and its maximum working pressure depends on the safety valve on the connecting block

Coding A LS relief valve limits the pressure at port A to... bar(Pressure limiting range 50-400bar)

Coding B LS relief valve limits the pressure at port B to... bar(Pressure limiting range 50-400bar)

Coding A...B... LS relief valve limits the pressure of port A and port B to... bar... bar respectively (Pressure limiting range 50-400bar)

13 On/off function

No code No on-off function

F1 Output flow from electrical on-off to actuator at port A

F2 Output flow from electrical on-off to actuator at port B

F3 Output flow from electrical on-off to actuator at port A and B

FP1(2 3) Similar to F1 (2,3), but the maximum pressure of A/B port is limited by the electric proportional relief valve

FPH1(23) Similar to FP1 (2,3), but with additional buttons for manual emergency operation

S,S1 Through the remote control signal ports U and W, respectively control the flow on and off of ports A and B of the directional spool valve .

X,SB Through the remote control signal oil port X (shared by oil ports A and B) or SB (oil port B), the flow of port A/B of the directional spool valve direction is controlled

14 Operation of directional spool valves

/A Manual operation, spring centering and positioning

/C Manual operation, friction positioning (stepless adjustment)

/H Hydraulic proportional operation

/E Electro hydraulic proportional operation

/HA Hydraulic control proportion+manual operation

/EA Electro hydraulic proportion+manual operation

/...Additional 1 No code= Standard handle

1=Without handle

Name	Manual		Electro hydraulic control		hydraulic control	
	Spring return	Card slot positioning	Pure electrohydraulic control	Combined with manual	Pure hydraulic control	Combined with manual
Code	A	C/D	E	EA	H	HA
Graphical symbols						
Manipulaton oarameters	Operating angle min. approx 5* max. approx 30*		Control current ratio I/I_1 min.approx 0.2 maxaapprox 1		Control pressure (ban min. About 5. max About 18. the maxmum allowable pressure is sobar	



Ordering code

15 Auxiliary block

- /2** Standard type, with only A and B threaded interfaces, and no auxiliary block with any additional functions
- /2AS...,BS...** The auxiliary block with buffer valve (to the other side) at A and B is marked with pressure (bar)
- /2AN...,BN...** Auxiliary block with buffer valve and makeup valve at A and B, indicating pressure (bar)
- /2AL...,BL...** Auxiliary block with balance valve at A and B, indicating pressure (bar)
- /2DEH...** Auxiliary block with hydraulic control check valve at A and B, indicating pressure (bar)

16 End plate

- E1** Standard type. The return oil of pilot control oil flows back to the oil tank from the T-port, so the T-port must be connected with the oil tank through a separate external pipeline and the pipeline must be kept smooth, otherwise the pressure holding of the T-port will squeeze the spring cover and deform, resulting in oil leakage or failure to reverse;
- E2** As with E1 type end plate, the T-port must be connected with the oil tank by a separate external pipeline. When several groups of proportional directional spool valves are connected in series to share a hydraulic pump, port Y is used to connect the LS port on the downstream proportional directional spool valve connection block; Note that the Y port of a group of multi way valves farthest from the pump must be connected to the oil tank with a separate external pipeline and the pipeline must be kept smooth;
- E4** The return oil of pilot control oil flows back to the oil tank through the one-way valve from the R port, without external pipeline, but it must be used under the condition that the back pressure of the return oil R port is less than 10 bar, otherwise the reversing function will be affected during the electric proportional control
- E5** Similar to E2, without T interface (like E4)
- E17** As E1, but with additional G3/8 pipe thread interfaces P and R
- E18** As E2, but with additional G3/8 pipe thread interfaces P and R
- E19** As E4, but with additional G3/8 pipe thread interfaces P and R
- E20** As E5, but with additional G3/8 pipe thread interfaces P and R
- ZPL32** Transition connecting plate for combination with size 3 proportional directional spool valve

End plate		Threaded interface	explain Order code of tailboard as a separate part	for example SL2-E1 SL2-E2-G24 SL2-ZPL32
External oil return (separate oil return)	Internal control oil return passage			
E1	E4	T, Y = G 1/8 P and R = G 3/8	Standard tailboard	
E2	E5		With additional oil inlet port Y, e.g. LS control oil pipe for connecting another TSV valve block	
E17	E19		Like E1/E4, but with additional interfaces P and R	
E18	E20		like E2/E5, but with additional interfaces P and R	
ZPL32	T = G 1/8		T transition block from size 3 to size 2	

Note: The internal control oil return passage can only be used in the system with the return oil pressure lower than 10 bar

Rated voltage of solenoid

Connector standard DIN EN 175301-803A IP 65 (IEC 60529)

G12 12VDC

G24 24VDC



Valve hydraulic circuit

Connection block

The connection block has two basic forms

- 1) The TSL connection block is equipped with 3-way flow control valve, which is used for the constant displacement pump system (open center system)
 - 2) TSV type connection block is used in variable displacement pump system (closed center system), constant pressure system, or system with TSL type proportional directional spool valve supplying oil in parallel as downstream proportional directional spool valve.
- Note: The connection block of size 2 can be retrofitted to switch between TSL and TSV functions

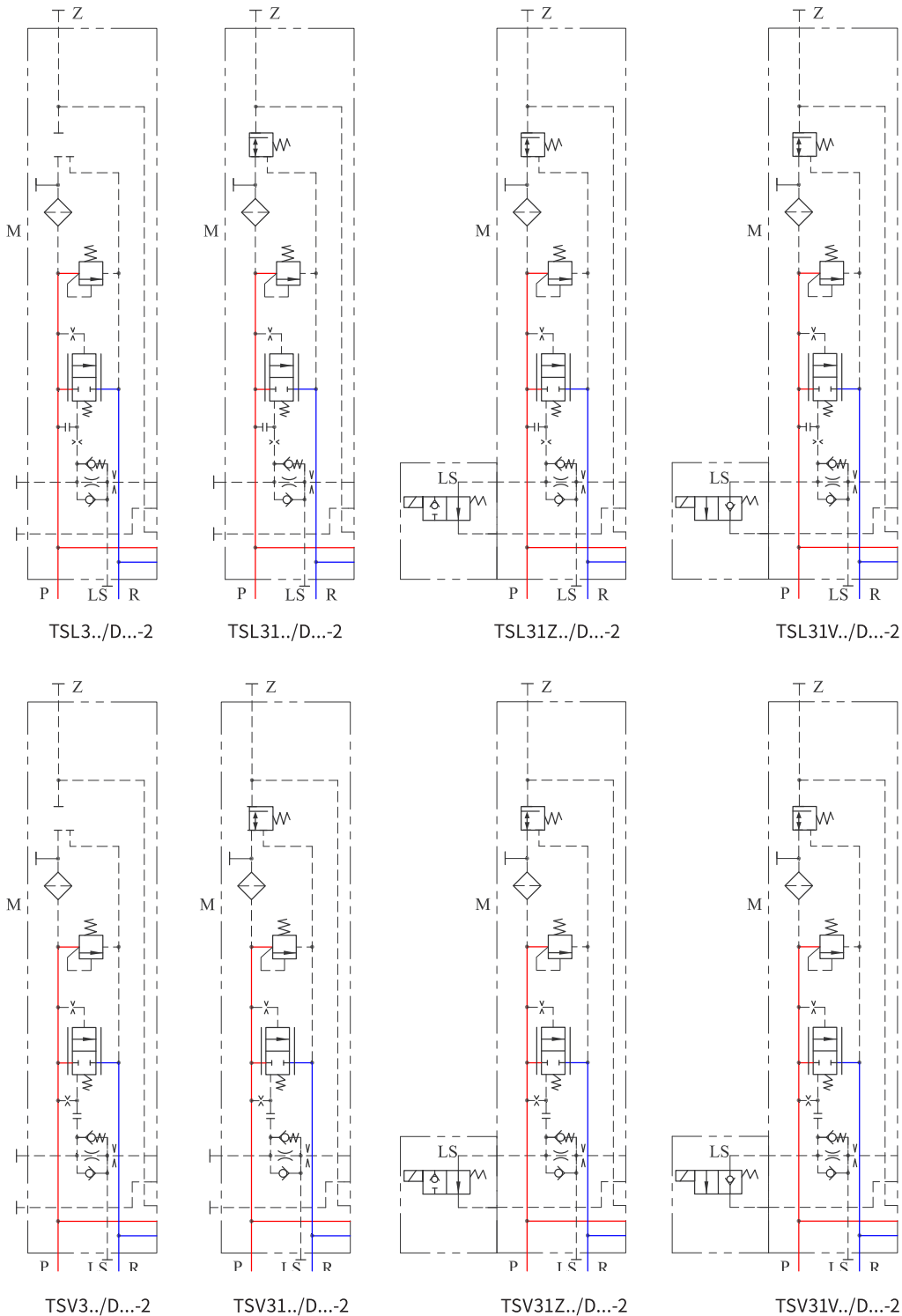



Valve hydraulic circuit

TSL(V)3.../D...-2 Overall dimension of connection block

Thread standard
ISO 228/1(BSPP)

	P, R	LS, M	Z
TSL 3...	G1/2	G1/4	G1/4
TSV 3...	G1/2	G1/4	G1/4

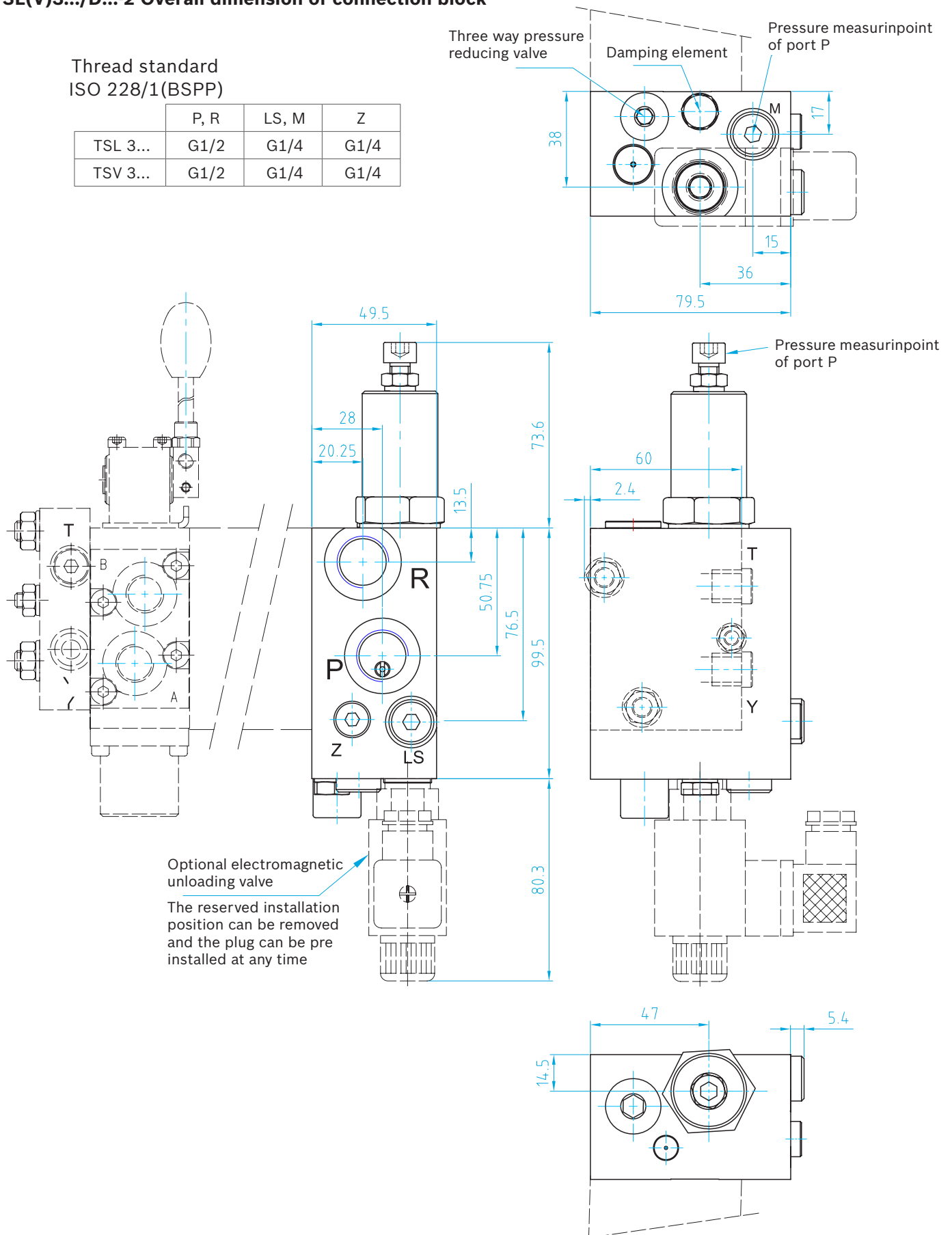



Spool valves hydraulic circuit

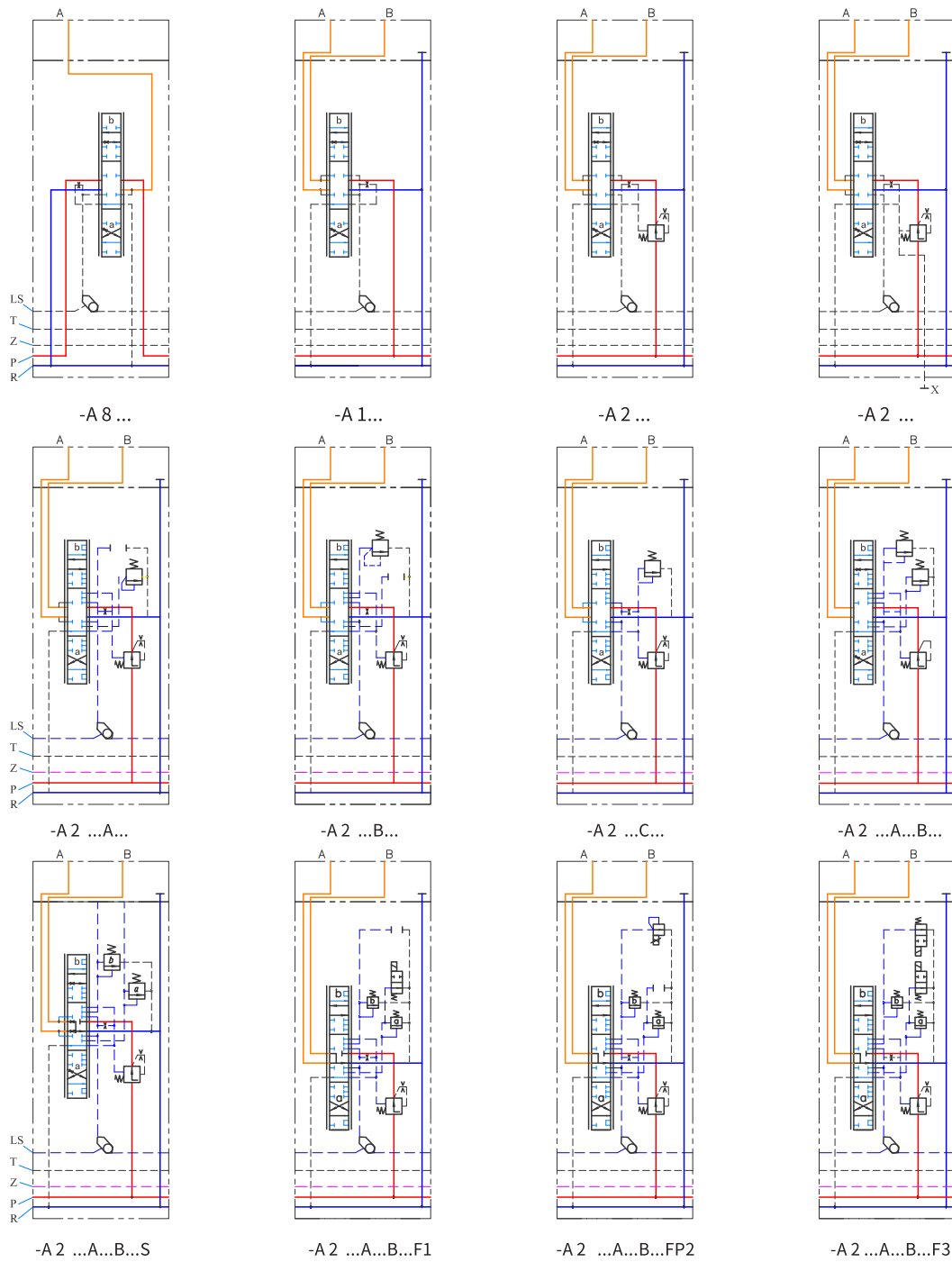

Possible combinations:

- | | | | |
|-----------|------------------------|------------------------|------------------------|
| ...S | ...F1,FP1,FPH1(X) | ...F2,FP2,FPH2(X) | ...F3,FP3,FPH3(X) |
| A...S | A...F1,FP1,FPH1(X) | A...F2,FP2,FPH2(X) | A...F3,FP3,FPH3(X) |
| B...S | B...F1,FP1,FPH1(X) | B...F2,FP2,FPH2(X) | B...F3,FP3,FPH3(X) |
| A...B...S | A...B...F1,FP1,FPH1(X) | A...B...F2,FP2,FPH2(X) | A...B...F3,FP3,FPH3(X) |



Unit Dimensions

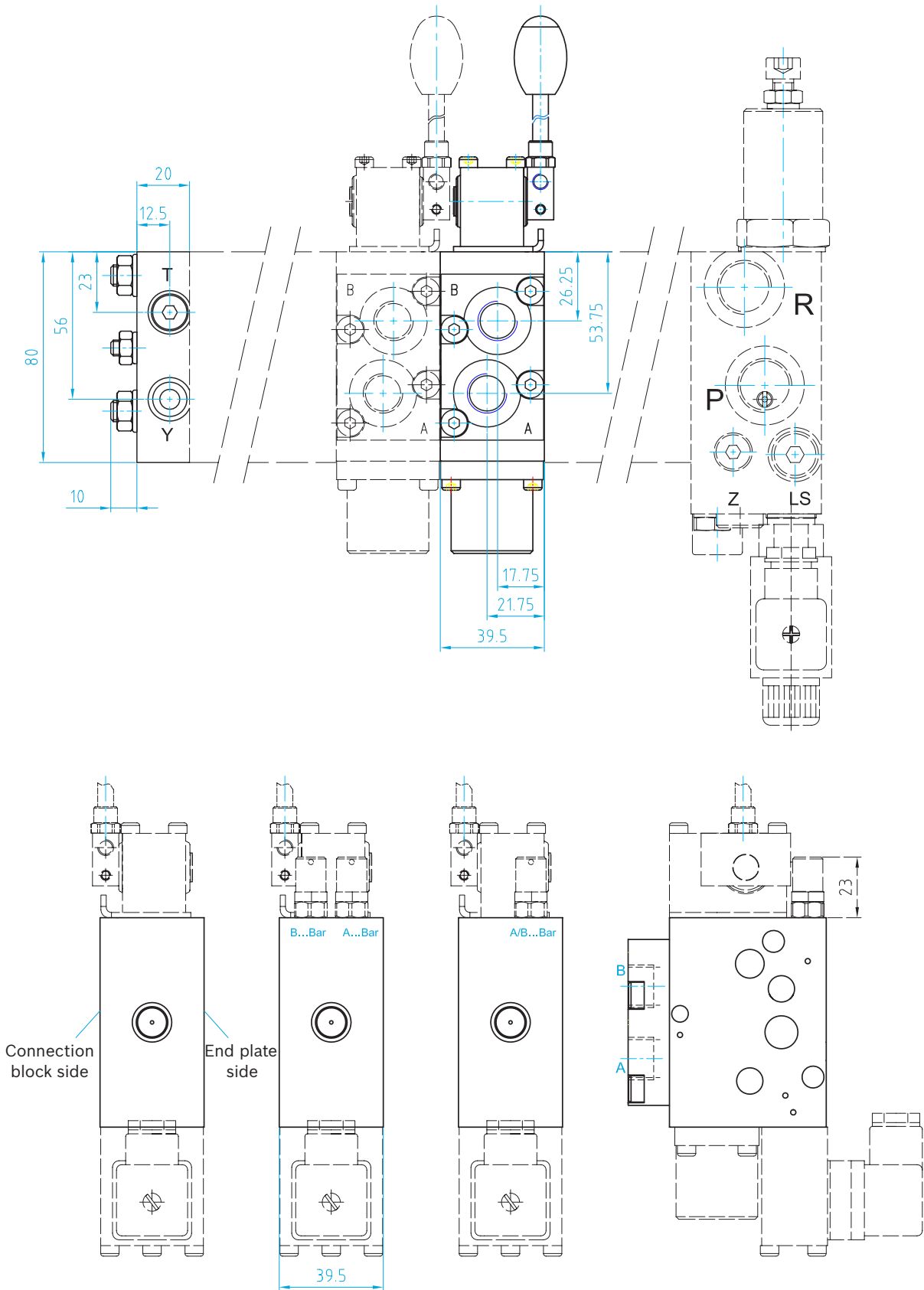



Unit Dimensions

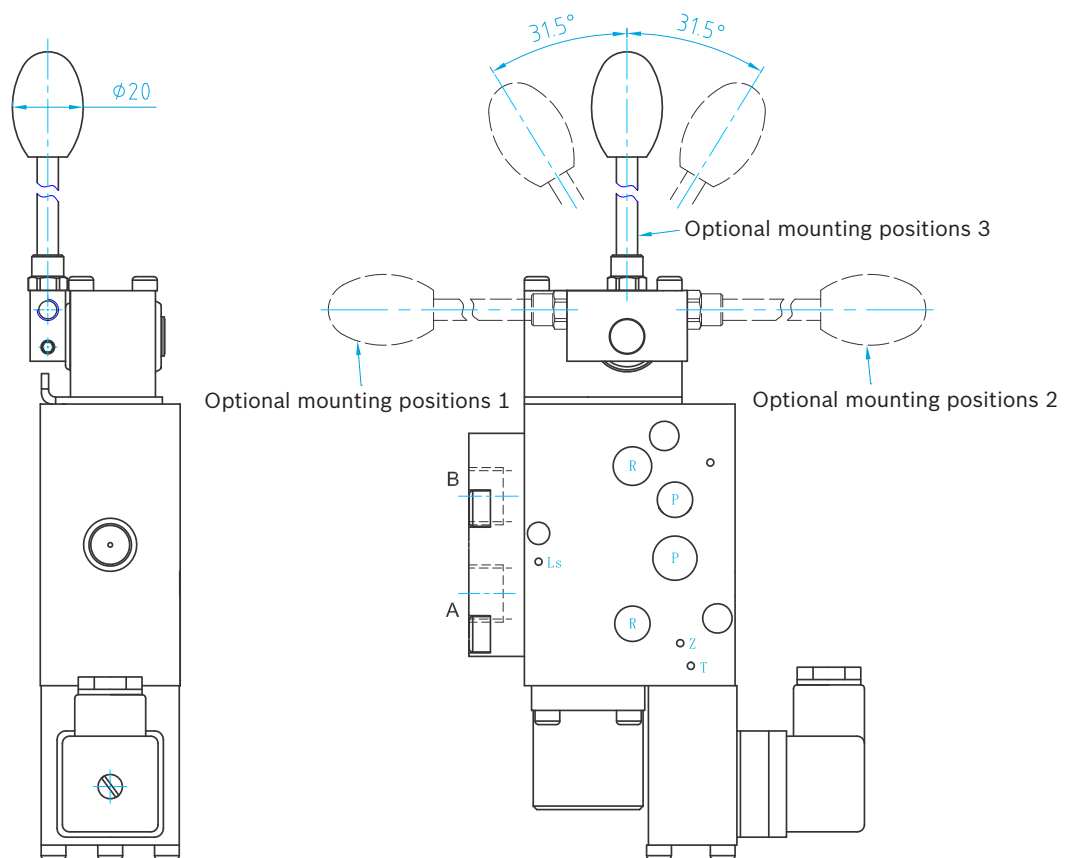
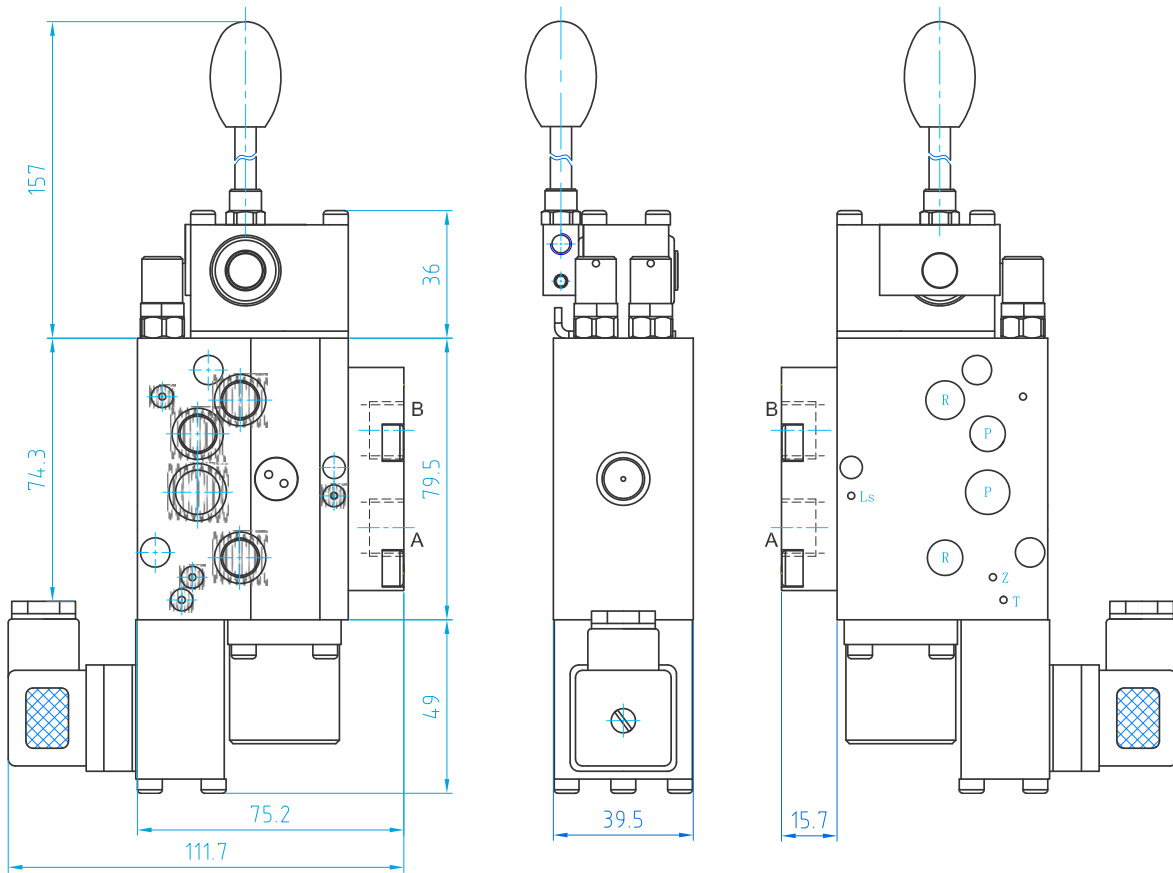



End plate hydraulic circuit

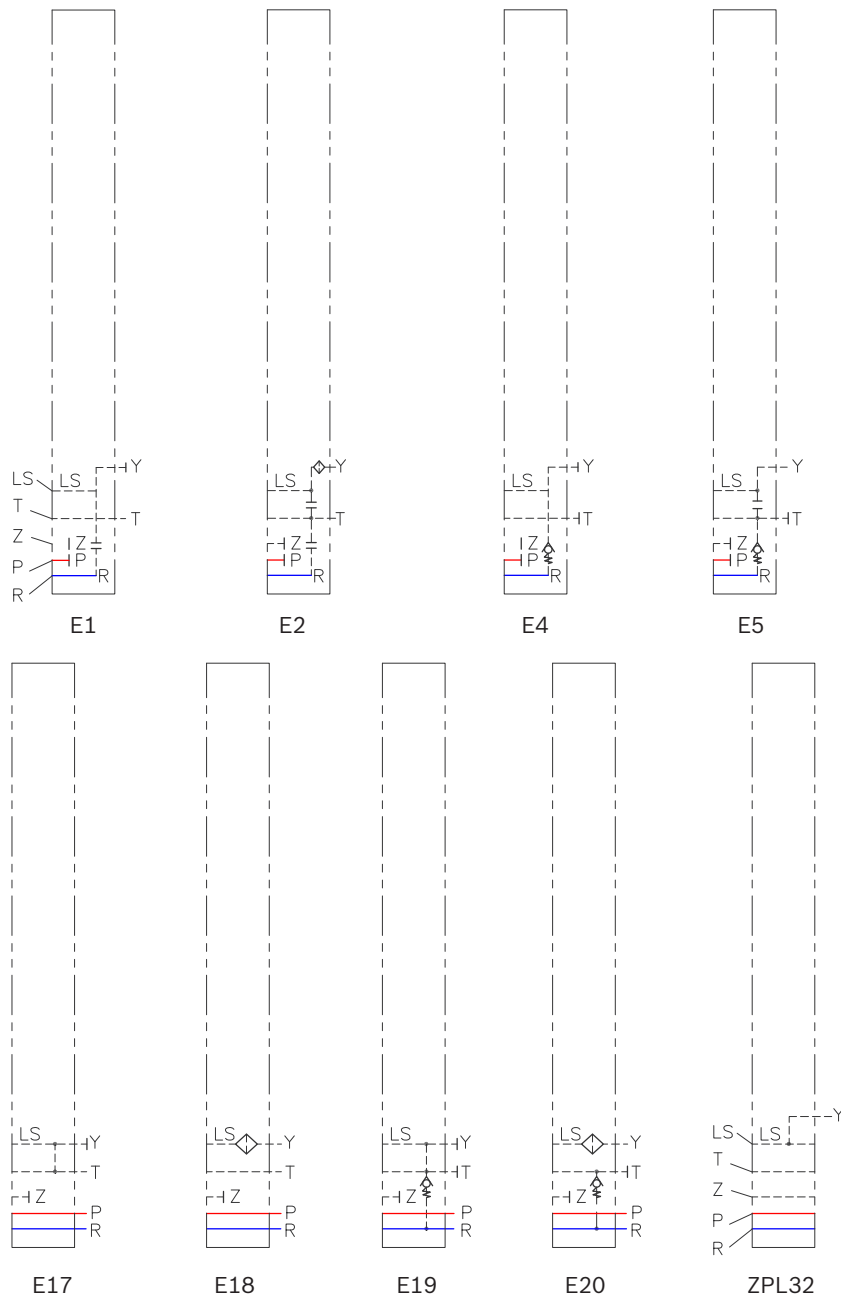

Function description

- E1 Standard type, most commonly used, control oil leakage and separate pipe returns to oil tank
- E2 Same as E1, and port Y is connected with downstream proportional directional spool valve LS port or a separate pipe returns to the oil tank
- E4 When the return oil at R port has no back pressure, control the oil leakage to return oil through the internal oil circuit at R port
- E5 Same as E4, and port Y is connected with downstream proportional directional spool valve LS port or a separate pipe returns to the oil tank
- E17 Same as E1, with additional G3/8 pipe thread P and R ports
- E18 Same as E2, with additional G3/8 pipe thread P and R port
- E19 Same as E4, with additional G3/8 pipe thread P and R port
- E20 Same as E5, with additional G3/8 pipe thread P and R port
- ZPL32 Transition block connecting the second and third size



End plate hydraulic circuit

Size 2 Twin solenoid parameters

Size 2 Proportional directional spool valves adopt wet twin solenoid, the hydraulic oil can enter inside the twin solenoid for protection, rust prevention and lubrication, Therefore, no lubrication maintenance is required. Specific parameters are as follows:

Parameters of twin proportional solenoid (control ways: E , EA)

Rated voltage U_N :12VDC

Rated voltage U_N :12VDC

Coil resistance R_{20} :6.7

Coil resistance R_{20} :28

Limiting current I_{lim} :1.16A

Limiting current I_{lim} : 0.58A

In order to get better proportional control characteristics, it is recommended to add dither signal to the proportional electromagnet. The parameter setting is as following:

PWM frequency: 1K

Dither frequency: 40-70Hz Preferably 55Hz

Dither amplitude: $20\% \leq AD \leq 35\%$

$$A_D (\%) = \frac{I_{\text{peak-peak}}}{I_G} \cdot 100$$

When there is no dither signal, fine proportional control characteristics can be get by adjusting PWM frequency, PWM frequency 60-100Hz, Preferably 75Hz

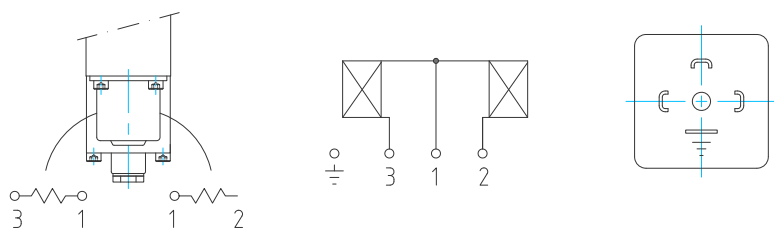
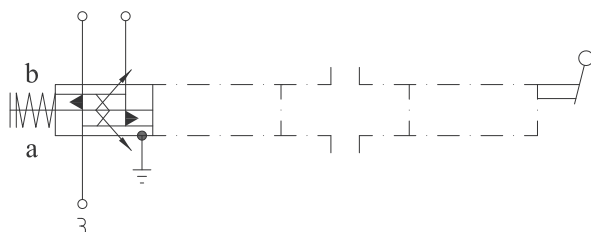

Pin definition of the twin solenoid

Twin solenoid for on-off control function and proportional pressure limit.

See the following figure for the wiring mode

Rated voltage U_N :12VDC

Rated voltage U_N :12VDC

Coil resistance R_{20} :6.7

Coil resistance R_{20} :28

Limiting current I_{lim} :1.16A

Limiting current I_{lim} : 0.58A

1)Wherein, 1-3 coils control bit B, 1-2 coils control bit A

2)Standard for twin solenoid plug DIN43650A(ISO4400)

3)When supplying, the multi way valve electromagnet is equipped with a waterproof IP65 standard connection plug matching the electromagnet plug shown in the right figure

4)See sample for proportional amplifier TS/PA222-812/24

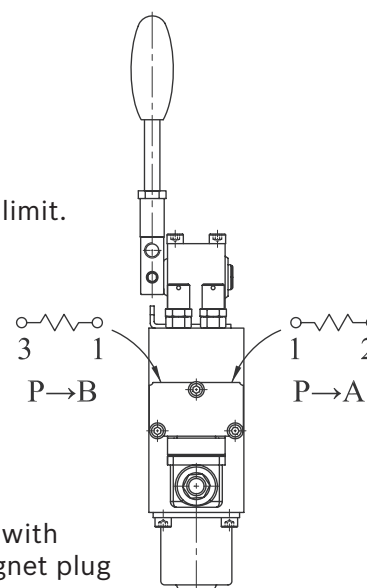

F. FP type breaking control function wiring diagram



Proportional directional spool valve characteristic curve

Pressure limiting valve in the connection block
 Type TSL 3../D../-2
 TSV 3../D../-2

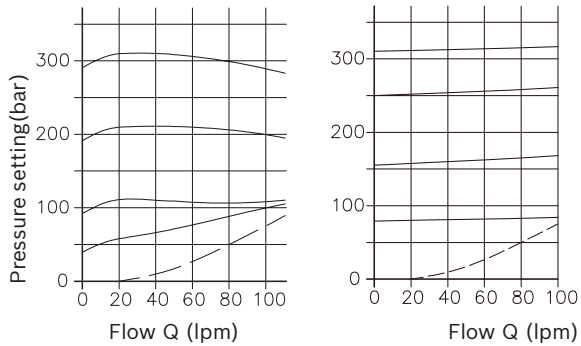

Prop. pressure limitation in the connection block
 Type TSL(TSV ..V ZVM)

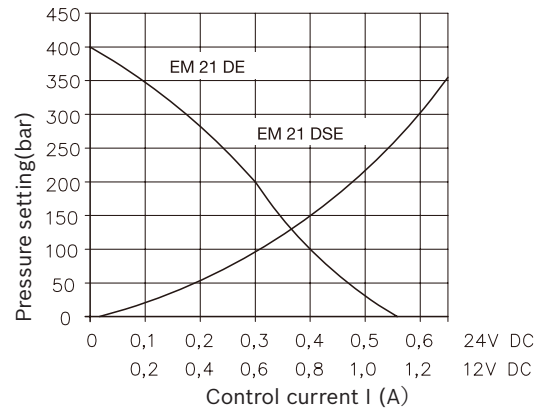

Connection block type TSL..
 Circulation pressure P R

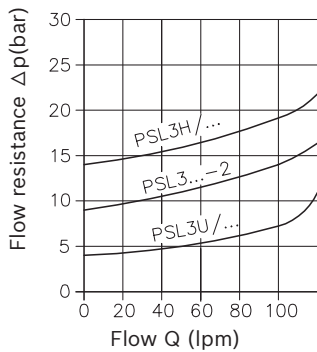

Directional spool valve
 P A(B), A(B) R

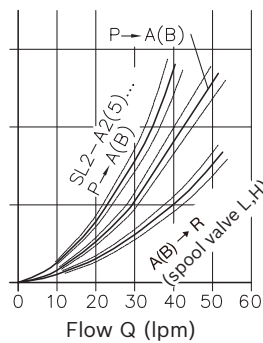

Prop. pressure limitation
 Coding A.. B.. acc. to table 17. sect, 3.2.1

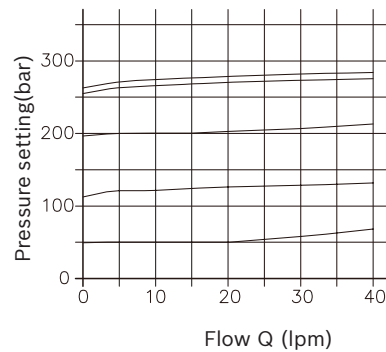

2-way inflow controllers

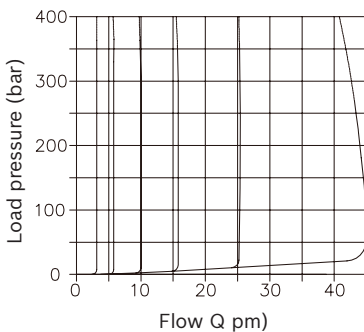

Prop. pressure limitation
 Coding FP(H) 1, (FP(H) 2, FPH) 3, table 17, sect. 3.2.1

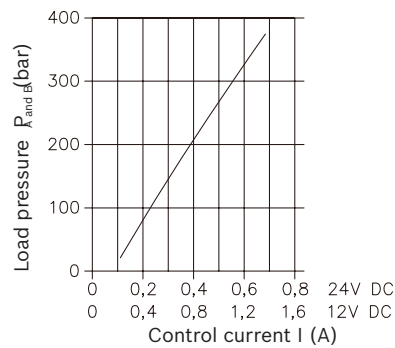

Control curve for consumer flow
 (Guide line, example for directional spool valve type SL 2-2../.. with inflow controller)

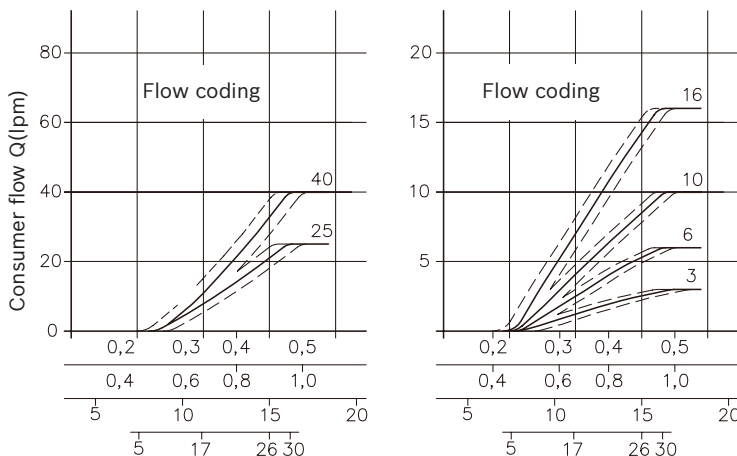

- ← Control current 1(A) 24V DC
- ← Control current 1(A) 12V DC
- ← Control pressure bar hydraulic actuation HA
- ← Angle (at hand lever, manual actuation A



Proportional directional spool valve characteristic curve

Port mark

Port size

P	Pressure oil inlet	At connection block, size G1/2; The oil port of E17-E20 terminal block is G3/8
R	Return	
M	Pressure tap for inlet pressure	At connection block, size G1/2; The oil port of E17-E20 terminal block is G3/8
Z	Pilot pressure input/outlet	At connection block, size G1/8
LS	Load pressure tap(TSL)	At connection block, size G1/8
	Load pressure tap(TSV)	At connection block, size G1/8
	Connected to LS (X) port of variable displacement pump	At connection block, size G1/8
A/B	Load port	At the directional spool valves, size G3/8
U/W/X	Function cut-off control port	At the directional spool valves, size G1/8
T	Pilot oil return port	At the end plate, size G1/8
Y	Downstream proportional directional spool valves LS oil inlet	At the end plate, size G1/8

Fluid parameters

- 1)Hydraulic oil accuracy reaches international standard IOS 4406 23/19/16(Equivalent to Level 7 in America NAS1638
- 2)Viscosity range: about 4~1500 cSt, optimum viscosity: about 10~500 cSt
- 3)Synthetic medium: polyalkyl ethylene glycol (HEPG) and synthetic grease (HEES), operating temperature is about+70 ° C
- 4)Operating oil temperature - 25 ° C~+80 ° C
- 5)Operating ambient temperature - 40 ° C~+80 ° C
- 6)The oil must be maintained according to the actual cleanliness of the hydraulic oil, the filter element of the oil filter must be replaced regularly, and the oil tank and pipeline must be cleaned as necessary

TSL/V-3

Proportional directional spool valves type series 3
 Pmax=420 bar
 Qmax=120 lpm



Index

Page No

• Product overview	15
• Working principle	16-17
• Ordering code	18-22
• Hydraulic circuit	23
• Directional spool valves hydraulic circuit	24
• Middle plate hydraulic circuit, Auxiliary block hydraulic circuit	25
• End plate hydraulic circuit	26
• Valve curve and parameters	27-30
• Unit Dimension	31-39
• Installation and start-up instructions	40-41

Product overview

Load-sensing Proportional directional spool valves types series 3 can be used in constant displacement pump and variable displacement pump hydraulic system. Stepless speed regulation can be carried out on the cylinder or motor by means of electronic control · manual and hydraulic control. The output flow is only proportional to the input current signal or handle lever, and the speed is independent of the load, so several actuators can work at different pressure and speed independently until the total required flow rate of the actuator is greater than the maximum flow rate that the pump can provide.

The valve contains three functional blocks: connection block, directional valves and end plate. Each function block has different functions for option. Maximum of 12 sections in each bank of valve.



Working principle

TSL proportional directional spool valves is used in the constant displacement pump system (the open center system). Figure 1, the hydraulic schematic diagram; Figure 2, the structure of the proportional directional spool valves. The 3-way pressure compensation valve in the TSL connection block works in coordination with the shuttle valve network in the directional spool valves, so that the inlet pressure of the connection block is always 9~15 bar higher than the maximum load pressure of each directional valve. The extra flow provided by the constant displacement pump returns back to the oil tank at the maximum load pressure. When all the directional spool valves are in the middle position, the 3-way pressure compensation valve unloaded at a low pressure about 9~15 bar. The 2-way flow control valve in the directional spool valves ensures the proportional directional spool valves actuator works independently at different pressure and speed. LS relief valve limits the maximum output pressure of the load port A or B of the directional spool valves.

Figure 1 proportional directional spool valves valve model

- TSL31F/380-3
- 32 H 80/63 A250B320 /EA
- 32 J 80/80 C320 /EA
- 32 J 40/25 C200 /EA
- 32 H 80/63 /A
- E1-G24

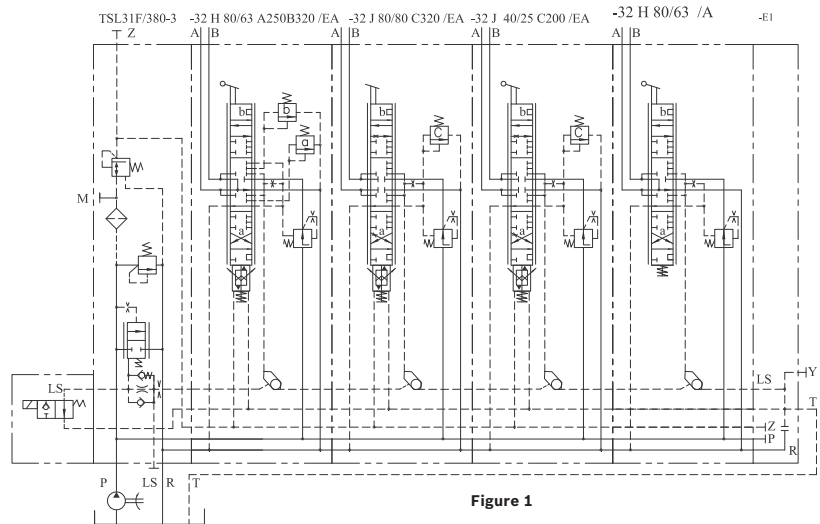

Figure 1

Figure 2 TSL valve Structure

- 1) The connection block is an oil inlet and return function block, and the 3-way pressure reducing valve provides pilot oil for the electric proportional control. The safety relief valve limits the maximum pressure of the inlet oil.
- 2) The directional valve integrates main functions, such as flow compensation valve, twin proportional solenoid and proportional pressure reducing valves, LS relief valve, shuttle valve, etc. The flow compensation valve maintains a fixed value pressure drop (6 bar, 9 bar, 13 bar) between the inlet and outlet of the main spool, thus, the flow rate at the port A and B is just proportional to the throttle area of the main spool. The twin coil proportional solenoid push two proportional reducing valves, and the pilot oil flow into the control chamber of the main spool, then the main spool moves with the input current of the coil.
- 3) The end plate is a functional block for block the oil, and let the leakage back to the tank through port T or through a check valve to port R. Y port in E2 or E20 end plate is used to connect LS port of other TSV type valve banks, which can be used in series with many groups of TSL and TSV valves.

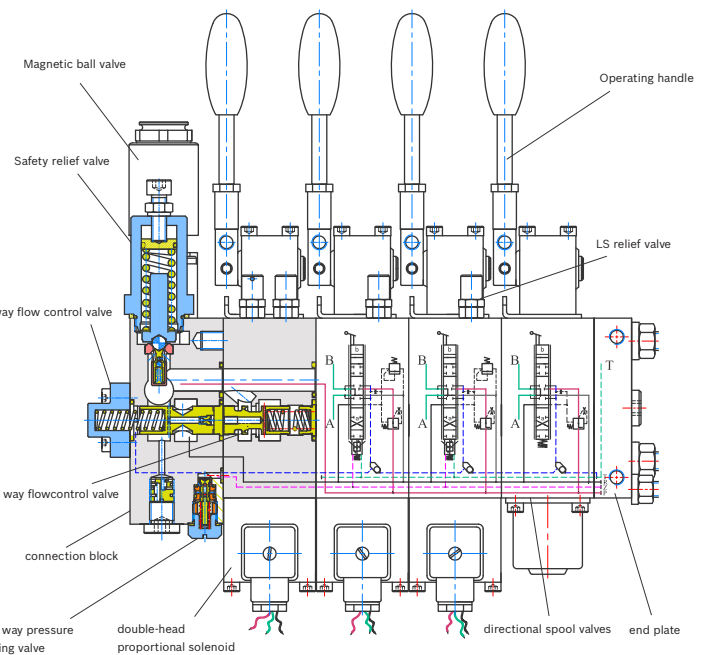

Figure 2



Working principle

TSV proportional directional spool valve is used in variable displacement pump system, i.e. closed center system. Figure 3, hydraulic schematic diagram; Figure 4, structure diagram. Compared with TSL block, the TSV block has no 3-way pressure compensation valve, The flow and pressure of the load sensing variable pump are determined by the proportional directional spool valves and its load. The shuttle valve network selects the maximum load pressure signal LS of all directional valves then transmits it to the variable pump. According to the load pressure, the variable pump adjusts its displacement to match the load requirement. When all directional spool valves are in the middle position, the load sensing variable displacement pump unloads at a very low pressure (about 14~25 bar) and a very small flow, the system is in standby mode. So closed center system has better energy-saving effect.

Ordering code shown in Figure 3

- TS-PSV41D/350-3
- 32 H 80/63 C200 /EA
- 32 H 80/63 C200 /EA
- 32 H 80/80 /E
- 32 H 40/25 /E
- E2-G24

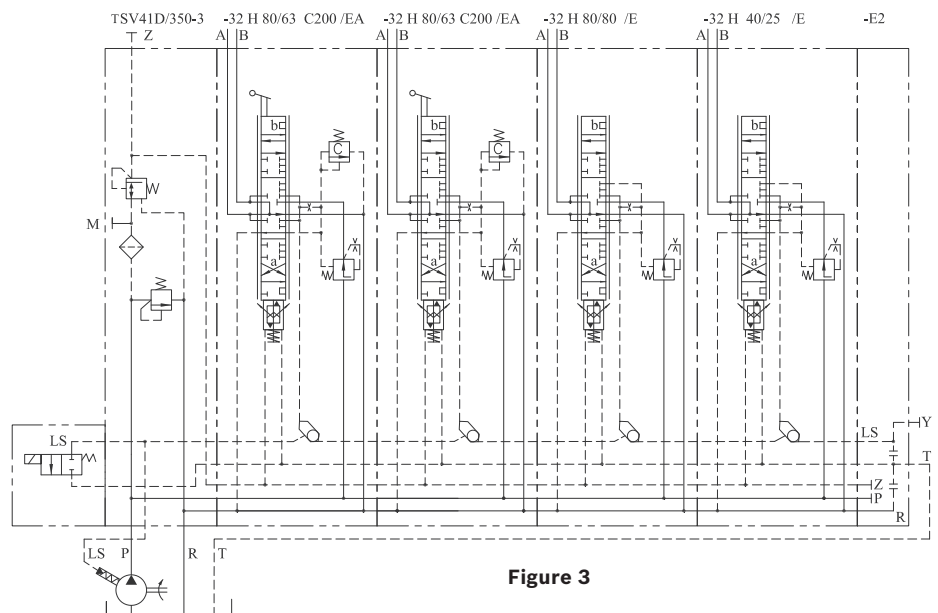

Figure 3

Figure 4 Valve structure

- 1) The connection block is an oil inlet and return function block, and the 3-way pressure reducing valve provides pilot oil for the electric proportional control. The safety relief valve limits the maximum pressure of the inlet oil. The directional valve integrates main functions, such as flow compensation valve, twin
- 2) proportional solenoid and proportional pressure reducing valves, LS relief valve, shuttle valve, etc. The flow compensation valve maintains a fixed value pressure drop (6 bar, 9 bar, 13 bar) between the inlet and outlet of the main spool, thus, the flow rate at the port A and B is just proportional to the throttle area of the main spool. The twin coil proportional solenoid push two proportional reducing valves, and the pilot oil flow into the control chamber of the main spool, then the main spool moves with the input current of the coil. The end plate is a functional block for block the oil,
- 3) and let the leakage back to the tank through port T or through a check valve to port R. Y port in E2 or E20 end plate is used to connect LS port of other TSV type valve bank, which can be used in series with many groups of TSL and TSV valves.

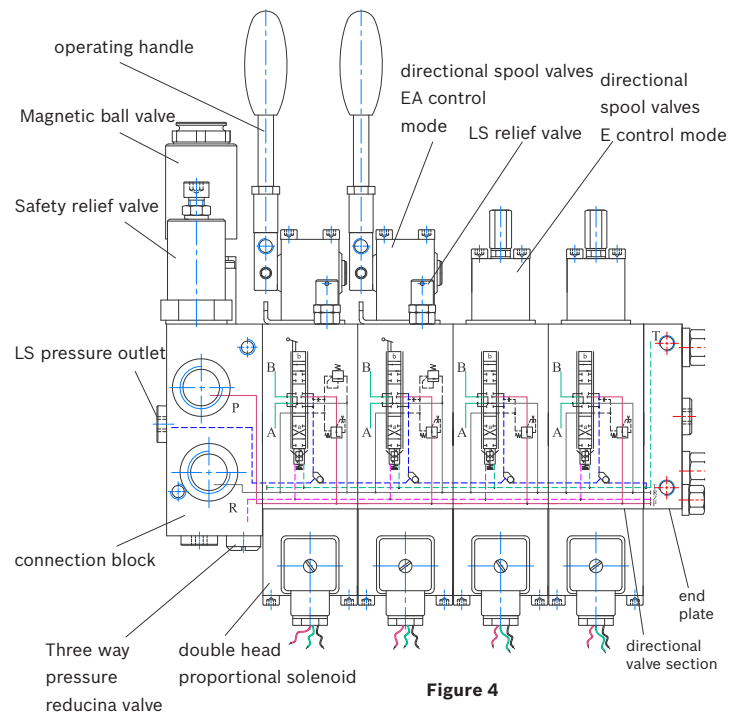

Figure 4



Advantages

- Effectively improve the efficiency of hydraulic system and reduce the heat generation;
- Provide electrical unloading safety protection for the Valve hydraulic system;
- Provide electric proportional control, hydraulic pilot control, manual control, detent positioning etc;
- Rated flow at ports A and B of can be specified, and the LS pressure limit can be set separately;
- Proportional directional spool valves with different flow rates and different limiting pressures can be combined freely;
- More suitable for the condition which load changes greatly and strict movement stability requirement;
- Each directional spool valve completes the combined action under different load conditions without affecting each other;
- Perfect integrated design, reducing the weight of the whole machine and reducing the installation space;
- The price and the delivery is friendly

Ordering code

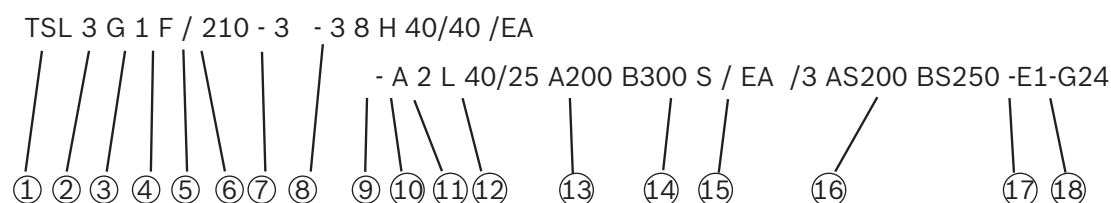

① **TS - THM Huade Hydraulics Pvt Ltd**

② **Basic type code for the connection block**

TSL Supply with constant delivery pump (open center)

TSV Supply with displacement pump (closed center)

TSM Supply with a constant delivery pump or a variable displacement pump.

ZPL53 Adapter plate enables combination with valve sections series 5

③ **P R ports size (DIN ISO 228/1 BSPP stand)**

3 G 1/2 Max inlet flow 80 lpm

4 G 3/4 Max inlet flow 100 lpm

5, 55 G 1 (55 only type TSV) Max inlet flow 130 lpm;

6 G 1 1/4 (only type TSV) Max inlet flow 200 lpm

④ **LS damping elements**

No coding Basic version

In TSL connection block, it is a damping element with integrated check valve, throttle hole and backpressure valve

In TSV connection block, it is a screw plug, no damping effect on the LS oil circuit

S,W Damping element with integrated check valve, throttle and backpressure valve. Code S only available for TSV connection blocks; Code W is like type S, with enhanced throttling effect (type W is not suitable for TSL 4K and PSL4Z)

G It is a combination of damping elements with check valve and throttle, no back pressure valve, so when the system pressure relief LS oil circuit has a strong damping, conducive to system stability (G type is not suitable for PSL4K type, TSL 4Z type and PSL5 type)

B Additional throttle damping in the LS circuit in the TSV only, B (standard throttle diameter Φ 0.8 mm) , B4 (Φ 0.4 mm) , B5 (Φ 0.5 mm) , B6 (Φ 0.6mm) , B7(Φ 0.7mm)

Z,K Check throttle valve + unloading valve (TSL type),

H 3-way flow control valve increases the pump circulation pressure (approx. 14 bar, TSL type) and is otherwise identical to the standard type.

U,UH Automatic reduction of pump unloading cycle pressure by means of a bypass valve (PSL5 models only)

Y,YH Only for TSL type connection block, the pressure oil from the outlet of the 3-way flow control valve is output through the power transfer port F on the connection block as the pressure oil source for the downstream hydraulic system.

⑤ **Pilot control oil supply**

No coding No 3-way pressure reducing valve; manual operated valves do not need pilot control oil, or pilot control oil is provided by external pressure reducing valve (pressure range 20~40 bar, flow rate approx. 2 lpm)

1 With 3-way pressure reducing valve, output pressure approx. 20 bar, standard type

2 With 3-way pressure reducing valve, output pressure approx. 40 bar



Ordering code

⑥ Solenoid Valve for pump unloading

NO coding No solenoid valve, but the installation position is reserved, can be installed at any time

F Normally open type solenoid valve i.e., the pump is unloaded when the valve is de-energized, and the valve bank is in standby state.

D Normally closed solenoid ball valve, i.e., the valve is energized when the pump is unloaded, and the valve bank is in standby state;

F... Normally open valve with pressure limiting valve for secondary pressure limiting (pressure range 50 to 400 bar). The maximum operating pressure of the proportional directional spool valves is the set pressure when the valve is de-energized (e.g. D50, i.e. the maximum operating pressure is 50 bar), and the maximum operating pressure of the proportional directional spool valves is set by the safety relief valve when the valve is de-energized.

D... Normally open solenoid ball valve with pressure limiting valve for secondary pressure limiting (pressure range 50 to 400 bar). The maximum working pressure of the valve is the set pressure when the valve is powered (e.g. D50, i.e. the maximum working pressure is 50 bar), and the maximum working pressure of the valve is set by the safety relief valve when the valve is de-energized.

PA,PB,PD proportional pressure limiting valves with various pressure ranges are available to limit the maximum L S pressure by means of a proportional relief valve. PA: 10...20 bar; PB: 15...20 bar .20 bar; PB: 15.... .250 bar; PD:18...400bar

⑦ Relief valve pressure setting on the connection block (not applicable for TSV... -3 and PSV6... -3)

No coding No safety valve (TSV type connection block only)

/... proportional directional spool valve pressure port P limit pressure to... bar, adjustment range 50~420 bar

⑧ Valve series

3 3 series valve

⑨ Port A/B size (DIN ISO 228/1 (BSPP))

3 G1/2

4 G3/4 (not recommended, because the G1/2 thread is large enough).

A For directional spool valves with external auxiliary block, see (6) for auxiliary block function. Note: When PSL5, PSV55, or PSM5 type connection blocks are combined with directional spool valves with external auxiliary blocks, SL3-ZPL33/5 type transition connection blocks must be installed behind the connection blocks, otherwise the connector cannot be installed at the interface R

ZPL3VQ Priority flow distribution, providing a defined or adjustable flow rate to the L port, with the rest of the flow rate being used in other oil circuits

ZPL3S(V)/H Fluid-operated shut-off valve. This shut-off valve can block the pump source oil circuit of all downstream actuators at will, when there is no signal, and all downstream valve block either connected (S), or disconnected (V), mainly used for performance or safety reasons need to lock the oil circuit of one or more actuators

ZPL3S(V)/E Electronically controlled shut-off valve. The function is the same as ZPL 3S(V)/H, but the on/off signal is electronically controlled.

ZPL3P/... With pressure limiting valve (pressure limiting for all downstream valve blocks)

ZPL3D(S) The ability to reduce the flow of downstream actuators at any time and still maintain speed control of all actuators over the entire range of travel of the slide valve. Which D means deceleration during power failure, and DS means normal speed during power failure

ZPL3D(S)/... The ability to reduce the flow at any time and still maintain speed control of all actuators over the entire travel range of the slide valve, with safety protection achieved by the pressure limiting valve. Where D indicates deceleration in case of power failure, DS indicates normal speed in case of power failure

ZPL33/5 Intermediate transition plate, thickness 5 mm

ZPL33/15 Intermediate transition plate, thickness 15 mm

ZPL33 Intermediate transition plate, thickness 49.5 mm

ZPL33-Z3 Intermediate transition plate additional oil port P

⑩ Basic directional spool valve unit

1 The directional spool valves without two-way flow control valve can not be installed LS relief valve, used for the working condition without multiple directional spool valves combined action at the same time

2,23,34 The directional spool valves with two-way flow control valve has a control differential pressure of about 6 bar, additional functions such as A/B port pressure limitation and A/B port flow cutoff, and is used for load pressure compensation of several actuators moving at the same time, of which 23 and 24 have additional damping, 23 throttle hole $\phi 0.3$ mm, 24 throttle hole in 0.5 mm



Ordering code

5,53,54 The directional spool valves with two-way flow control valve with a control differential pressure of approx. 9 bar is used to increase the output flow of the reversing block. Can only be used with TSL.... The increased flow rate is shown in the flow rate table in ⑫. The additional damping is available for 53 and 54, 0.3 mm in the 53 orifice and 0.5 mm in the 54 orifice. **8** Pre-selected switching valve is used to switch the up/down oil circuit, so that the on-board and off-board cannot be operated at the same time, which improves the safety and reliability of operation. Only G1/2 threaded interface is available, and only L type spool function is recommended, and it should be used at the maximum flow rate. It should be used at the maximum flow rate.

⑪ Spool function

Under the conditions that may cause system vibration (such as working arm amplitude or telescoping with jitter), especially when the proportional directional spool valves is used in combination with the counterbalance valve, it is recommended that the user choose the spool with the return throttle back pressure function when selecting the multiway valve, in which the J B, R, O type spool function has a back pressure value of about 20 bar in the full stroke; L, M, F, H type spool function has a maximum back pressure value of about 10 bar in the full stroke; I, Y, Z, V has a back pressure of about 100 bar in the near 1/3 spool stroke. Y, Z, and V generate a back pressure of about 100 bar near 1/3 of the spool stroke.

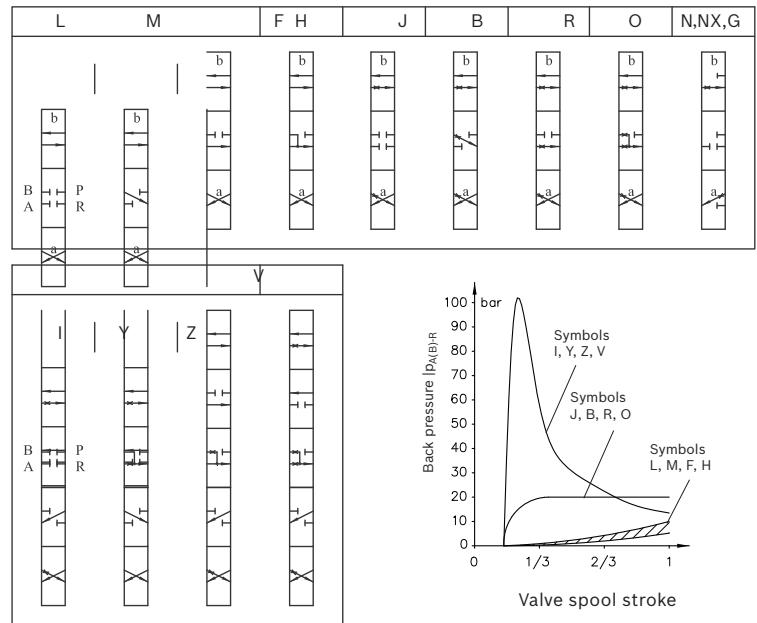

⑫ Rated flow of port A/B

.../... Rated flow values for ports A and B

Type of directional valve section block	Type of connection block	Rated flow of A/B port							
		3	6	10	16	25	40	63	80
2, 4	TSL or TSV	3	6	10	16	25	40	63	80
1	TSL	4	9	14	22	34	54	85	107
	TSV	$Q_{AB} = Q_{standard} \times \sqrt{0.2 \times P_{con}}$							
5	TSL.H. or TSV	4	9	14	22	34	54	85	107
8	TSL or TSV	The directional spool valves has only one output port A, whose flow code is shown in base type .							

Note: The flow rate can not be much larger than the actual requirement, otherwise, if in the actual use of spool travel limit Rayon to limit the maximum flow rate of A, B port, will directly shorten the flow of the linear control zone length of the directional spool valves so that the proportional control performance of the directional spool valves is reduced. Therefore, it is recommended that the user selects the flow rate is 1.15 times the actual demand flow rate, so that not only to design, commissioning to leave a certain margin, and can better play the proportional control performance of the directional spool valves

Q_{AB} --One directional spool valves A/B port maximum output flow

$Q_{standard}$ --Standard flow rates for directional spool valves with two-way flow control valves: 3, 6, 10, 16, 25, 40, 63, 80

ΔP_{con} --Control differential pressure

Note: When the directional spool valves base type is 1 (directional spool valves without two-way flow control valve) TSV type proportional directional spool valves used with load-sensitive variable pump, the output flow rate of the directional spool valves depends on the pressure setting of the load-sensitive variable pump "pressure-flow control valve", as can be seen from the flow formula, the greater the pressure difference, the greater the flow rate, the flow rate value through the table The flow rate value is calculated by the flow rate formula in the table.

⑬ A/B port pressure limit

(only for blocks with 2-way flow control valves, not used with buffer valves)

No coding The A/B port has no pressure limit, its maximum working pressure depends on the safety valve on the connection block

A... LS relief valve limits the pressure at port A to... bar (pressure limit range 50 to 400 bar)

B... LS relief valve limits the pressure at port B to... bar (pressure limit range 50 to 400 bar)

C... The LS relief valve limits the pressure at ports A and B to... bar (pressure limit range 50~400 bar), the same maximum pressure for AB port.



Ordering code

A...B... LS relief valves limit the pressure at ports A and B respectively to...bar...bar
(pressure limit range 50~400 bar)

14 On/off function

No code No on-off function

F1 Output flow from electrical on-off to actuator at port A

F2 Output flow from electrical on-off to actuator at port B

F3 Output flow from electrical on-off to actuator at port A and B

FP1(2 3) Similar to F1 (2,3), but the maximum pressure of A/B port is limited by the electric proportional relief valve

FPH1(23) Similar to FP1 (2,3), but with additional buttons for manual emergency operation

S,S1 Through the remote control signal ports U and W, respectively control the flow on and off of ports A and B of the directional spool valve .

X,SB Through the remote control signal oil port X (shared by oil ports A and B) or SB (oil port B), the flow of port A/B of the directional spool valve direction is controlled

15 Operation of directional spool valves

/A Manual operation, spring centering and positioning

/C Manual operation, friction positioning (stepless adjustment)

/D Manual operation, card slot positioning (neutral, A,B)

/H Hydraulic pilot operation

/E Electrohydraulic proportional operation

/HA Hydraulic pilot control+manual operation

/EA Electrohydraulic proportion+manual operation

/...Additional 2 No code= standard handle with a length of 150mm;

1=without handle; 2=with short handle 100mm long (suitable for A, EA, HA, C type control mode)

G Spring cover reinforced structure (for A,EA,C type control method)

V,VA

VB,VC Contact switch for valve spool position (suitable for A, EA, C, HA type control method). Where /V is the start signal in A or B direction; /VA is the start signal in A direction; /VB is the start signal in B direction; /VC is the start signal in A and B direction

T,TH Double-headed solenoid with manual emergency operation, / TH with emergency button (suitable for E, EA type control mode)

Nomenclature	Manual actuation		Electro-hydraulic actuation		Hydraulic actuation	
	Spring return	Detent	only purely electro-hydraulic	Comb. with manual actuation	only purely hydraulic	Comb. with manual actuation
Coding	A	C/D	E/EK	EA/EKA	H	HA
Symbols						
Manipulated variables	Actuation angle min. approx.5° max.approx.30°		Control current ratio I / I _n min. approx.0.2 max.approx.1		Control pressure (bar) min.approx.5 max. approx.18 max. perm.50 bar	

16 Auxiliary block (in combination with code A in , thread port series: /3... G1/2;/4... G3/4)

/3 /4 Auxiliary blocks without additional functions

/3AS...,BS...

/31AS...,BS...

/4AS...,BS... The auxiliary block with buffer valve (to the other side) at A and B is marked with pressure (bar)



Ordering code

- /4AS...,BS...** The auxiliary block with buffer valve (to the other side) at A and B is marked with pressure (bar)
- /4AN...BN...** Auxiliary block with buffer valve and makeup valve at A and B, indicating pressure (bar)
- /4AN BN** Auxiliary blocks with charge valves at A and B
- /4AN**
- /4BN** Auxiliary block with buffer valve at port A or B, auxiliary block with charge valve at port B or A, marked with pressure (bar)
- /3AL...,BL...**
- /3AL...3BL...** Auxiliary block with balancing valve at A and/or B, marked with pressure (bar)
- /3VV(VX,XV)** Auxiliary block (one or both sides) with EM32V shut-off type directional spool valves, locking actuator without leakage (Q_{max} approx. 80L/min)
- /4 DW2(5)** 3-position 3-way directional spool valves with both inlet and outlet differential pressure reduction, spool function N X, only one load port A (for controlling single-acting cylinder action)
- 42(5)AS...** Same as /4 DW, but with more buffer valve than /4 DW
- End plate**
- E1** Standard type. The return oil of pilot control oil flows back to the oil tank from the T-port, so the T-port must be connected with the oil tank through a separate external pipeline and the pipeline must be kept smooth, otherwise the pressure holding of the T-port will squeeze the spring 0
- E2** As with E1 type end plate, the T-port must be connected with the oil tank by a separate external pipeline. When several groups of proportional directional spool valves are connected in series to share a hydraulic pump, port Y is used to connect the LS port on the downstream proportional directional spool valve connection block; Note that the Y port of a group of multi way valves farthest from the pump must be connected to the oil tank with a separate external pipeline and the pipeline must be kept smooth;
- E3** The pilot control oil return must flow from the T port back to the tank. In addition, there is an extra. A solenoid ball valve is used to unload the proportional directional spool valves when all directional spool valves are in the neutral position to build up pressure at the pressure set by its safety valve;
- E4** The return oil of pilot control oil flows back to the oil tank through the one-way valve from the R port, without external pipeline, but it must be used under the condition that the back pressure of the return oil R port is less than 10 bar, otherwise the reversing function will be affected during the electric proportional control
- E5** Similar to E2, without T interface (like E4)
- E6** Similar to E3, without T interface (like E4)
- E17** As E1, but with additional G3/8 pipe thread interfaces P and R
- E18** As E2, but with additional G3/8 pipe thread interfaces P and R
- E19** As E4, but with additional G3/8 pipe thread interfaces P and R
- E20** As E5, but with additional G3/8 pipe thread interfaces P and R
- ZPL32** Transition connecting plate for combination with series 2 proportional directional spool valve

End plate		Threaded interface	explain Order code of tailboard as a separate part	for example SL3-E1 SL3-E6-G24 SL3-ZPL32
External oil return (separate oil return)	Internal control oil return passage			
E1	E4	T,Y = G 1/4 P,R = G 3/4	Standard end plate	
E2	E5		With additional oil inlet port Y, e.g. LS control oil pipe for connecting another TSV valve block	
E3	E6		Use WN1H type plate connected 3/2-way shut-off type reversing valve to close the unloading oil circuit of the pump at any time	
E17	E19		Like E1/E4, but with additional interfaces P and R	
E18	E20		Like E2/E5, but with additional interfaces P and R	
ZPL32	T = G 1/4		Transition block from size 3 to size 2	

Note: The internal control oil return passage can only be used in the system with the return oil pressure lower than 10 bar

Solenoid voltage (see attached diagram on back page for wiring diagram)

- G12** 12 VDC, (3-Pin) IP65
- G24** 24 VDC, (3-Pin) IP65
- G12H4** 12 VDC, (3-Pin) IP65
- G24H4** 12 VDC, (3-Pin) IP65
- DT12** 12 VDC electr. Connection via DT04-4P, IP67 plug Co.DEUTSCHDT24
- DT24** 24 VDC electr. Connection via DT04-4P, IP67 plug Co.DEUTSCH
- G24EX** 24 VDC Explosion-proof version ExmbIICT4G6
- G24MSHA** 24 VDC Explosion-proof version ExmbIMb



Hydraulic circuit

Connection block

The connection block has three basic forms

- 1) The TSL connection block is equipped with 3-way flow control valve, which is used for the constant displacement pump system (open center system)
- 2) TSV type connection block is used in variable displacement pump system (closed center system), constant pressure system, or system with TSL type proportional directional spool valve supplying oil in parallel as downstream proportional directional spool valve.
- 3) TSM type connecting block can be used in systems where both dosing pumps (open center circuit) and variable pumps (closed center circuit) supply pressure oil, and can be switched at any time by means of an external directional spool valve

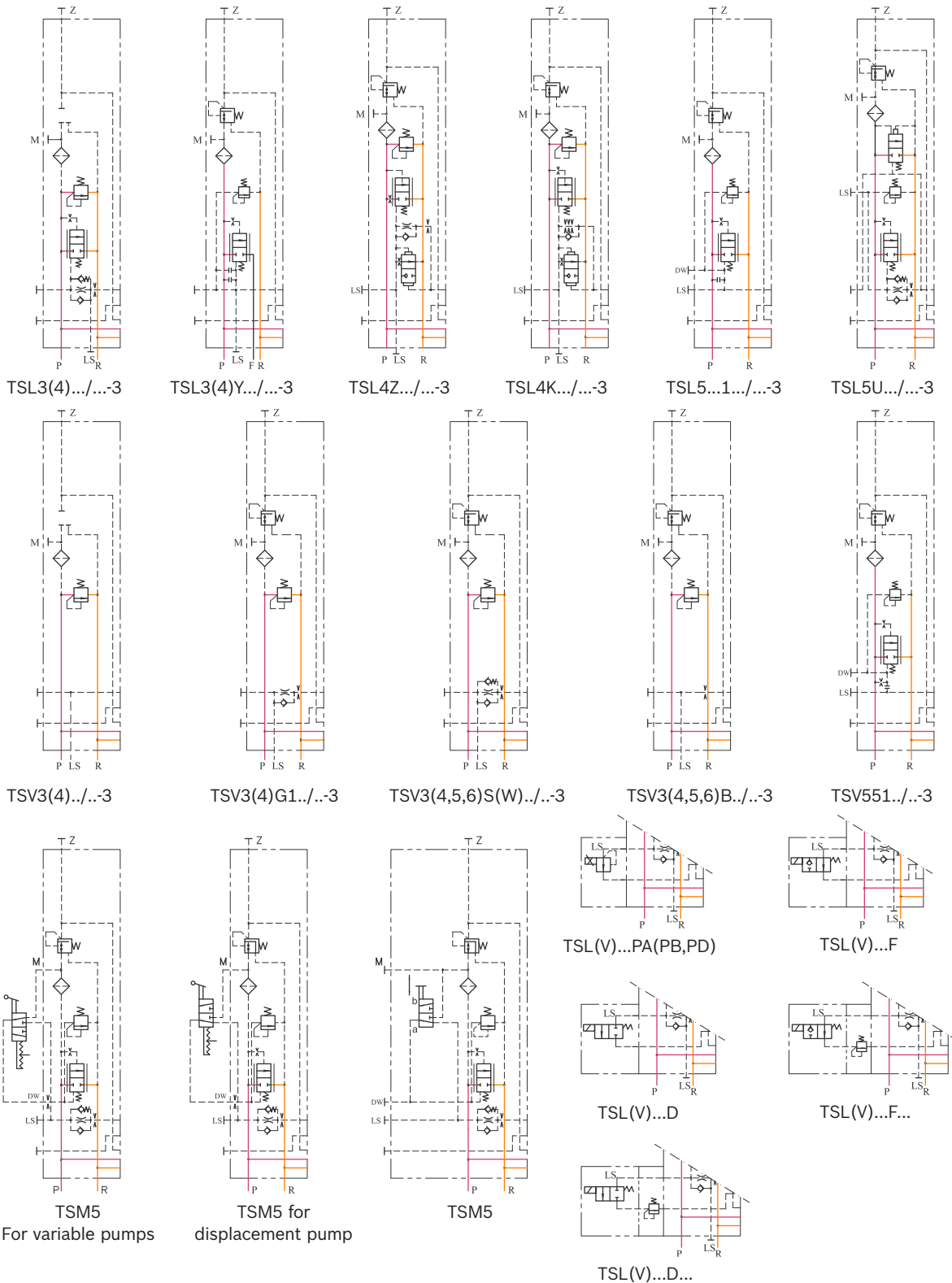



Directional spool valves hydraulic circuit

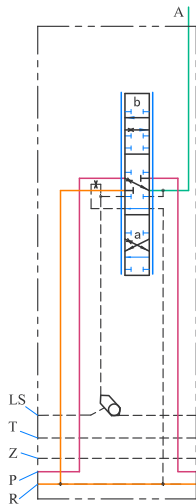

-3(4)8B...

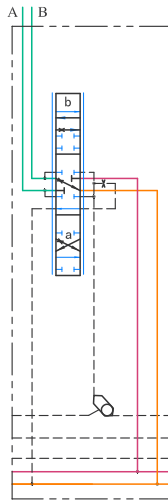

-3(4)1B...

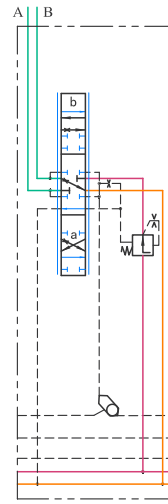

-3(4)2B...

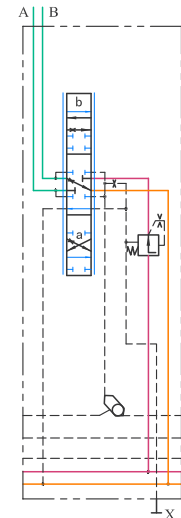

-3(4)2B...(A...,B... · A...B...X)

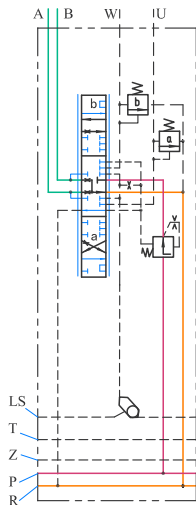

-3(4)2O...A...B...S

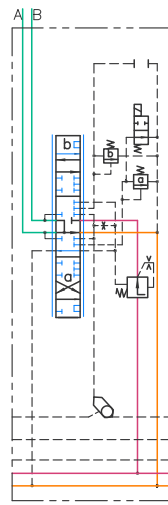

-3(4)2H...A...B...F1

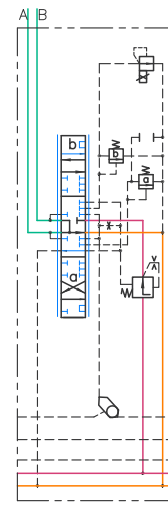

-3(4)2H...A...B...FP2

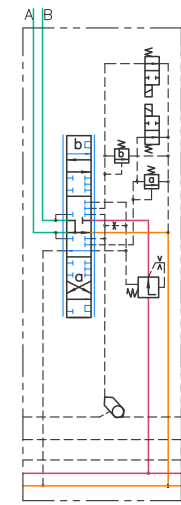

-3(4)2H...A...B...F3

Possible combinations

...S
A...S
B...S
A...B...S

...F1 · FP1 · FPH1(X)
A...F1 · FP1 · FPH1(X)
B...F1 · FP1 · FPH1(X)
A...B...F1 · FP1 · FPH1(X)

...F2 · FP2 · FPH2(X)
A...F2 · FP2 · FPH2(X)
B...F2 · FP2 · FPH2(X)
A...B...F2 · FP2 · FPH2(X)

...F3 · FP3 · FPH3(X)
A...F3 · FP3 · FPH3(X)
B...F3 · FP3 · FPH3(X)
A...B...F3 · FP3 · FPH3(X)

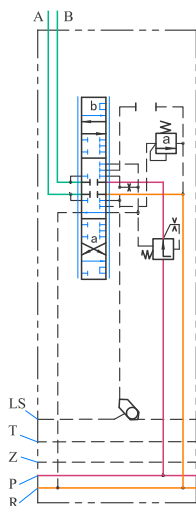

-3(4)2L...A...

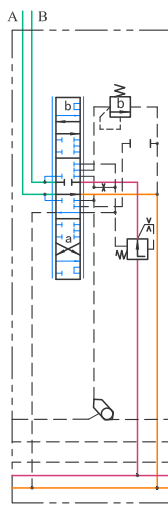

-3(4)2F...B...

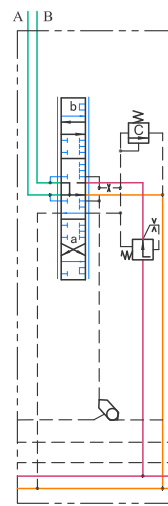

-3(4)2H...C...

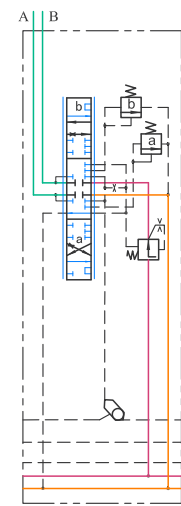

-3(4)2J...A...B...



Middle plate hydraulic circuit

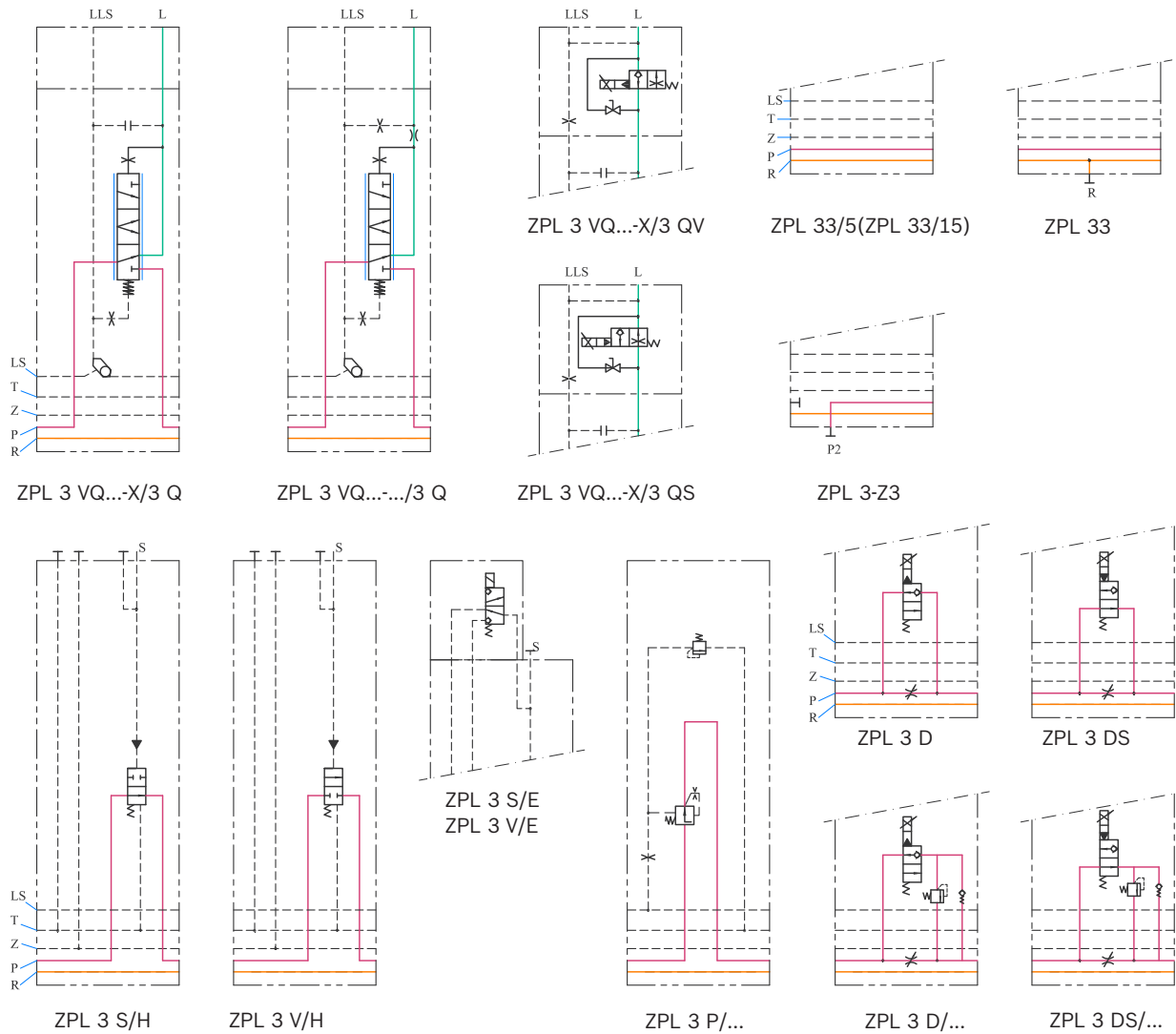

Auxiliary block hydraulic circuit

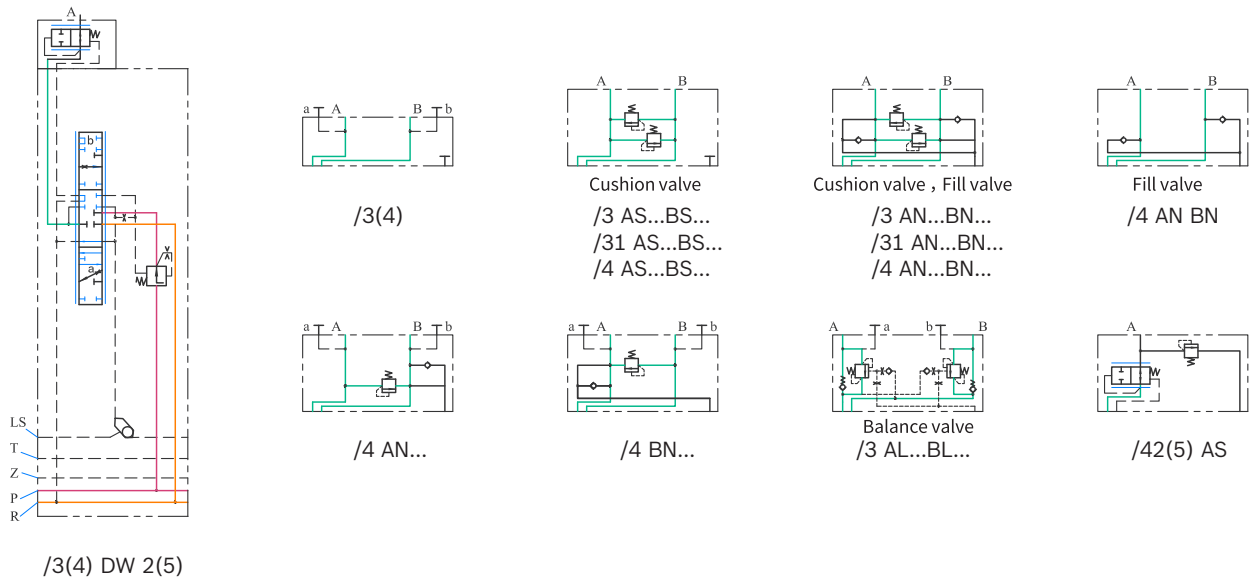



End plate hydraulic circuit

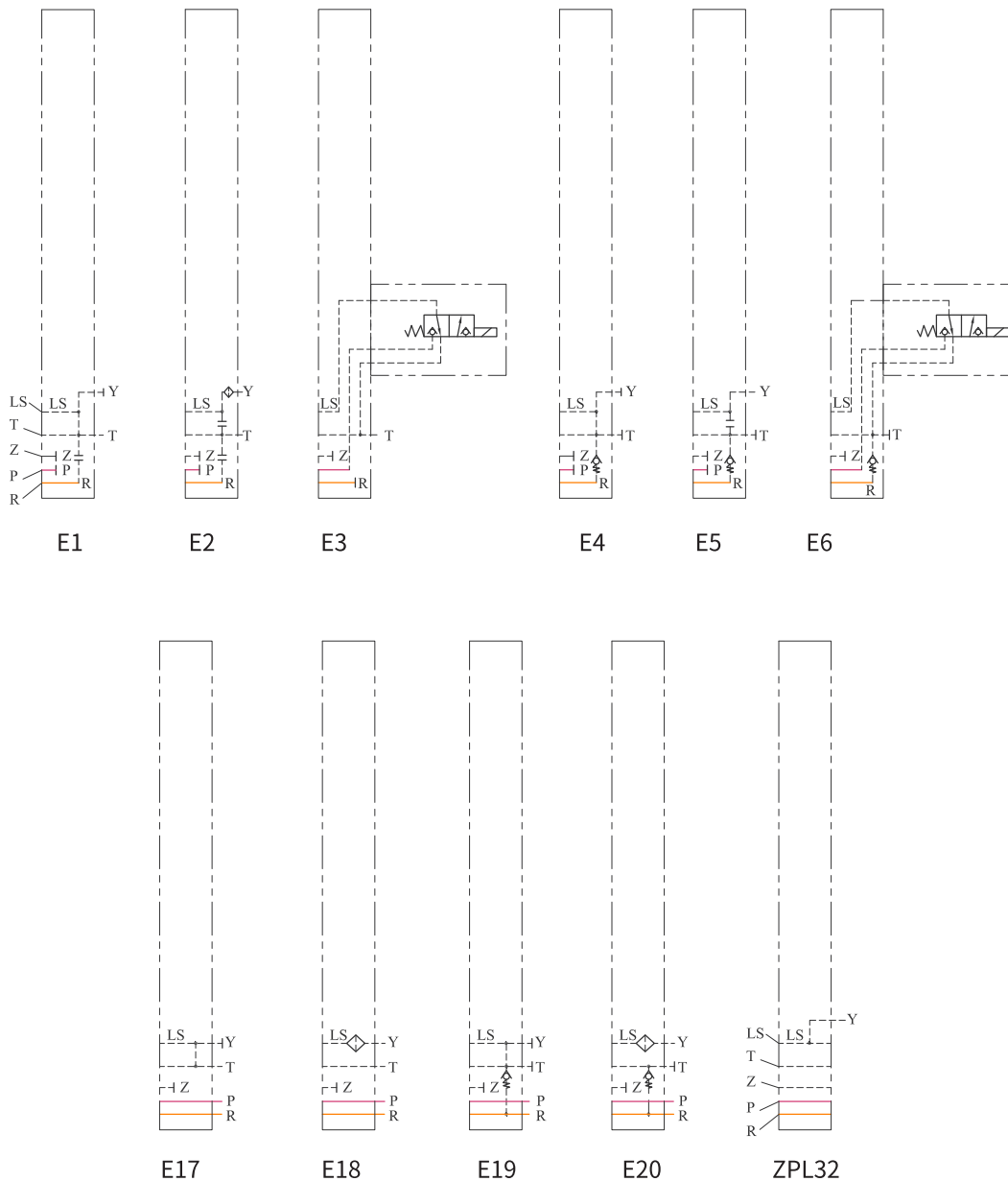

Function Description

- E1 Standard type, most commonly used, control oil leakage and separate pipe returns to oil tank
- E2 Same as E1, and port Y is connected with downstream proportional directional spool valve LS port or a separate pipe returns to the oil tank
- E3 Controls the unloading of the pump via a 2-position 3-way solenoid valve
- E4 When the return oil at R port has no back pressure, control the oil leakage to return oil through the internal oil circuit at R port
- E5 Same as E4, and port Y is connected with downstream proportional directional spool valve LS port or a separate pipe returns to the oil tank
- E6 Same as E3, control the leakage oil through the R oil circuit internal return oil
- E17 Same as E1, with additional G3/8 pipe thread P and R ports
- E18 Same as E2, with additional G3/8 pipe thread P and R port
- E19 Same as E4, with additional G3/8 pipe thread P and R port
- E20 Same as E5, with additional G3/8 pipe thread P and R port
- ZPL32 Transition block connecting the second and two series



Valve curve and parameters

Characteristic Curve

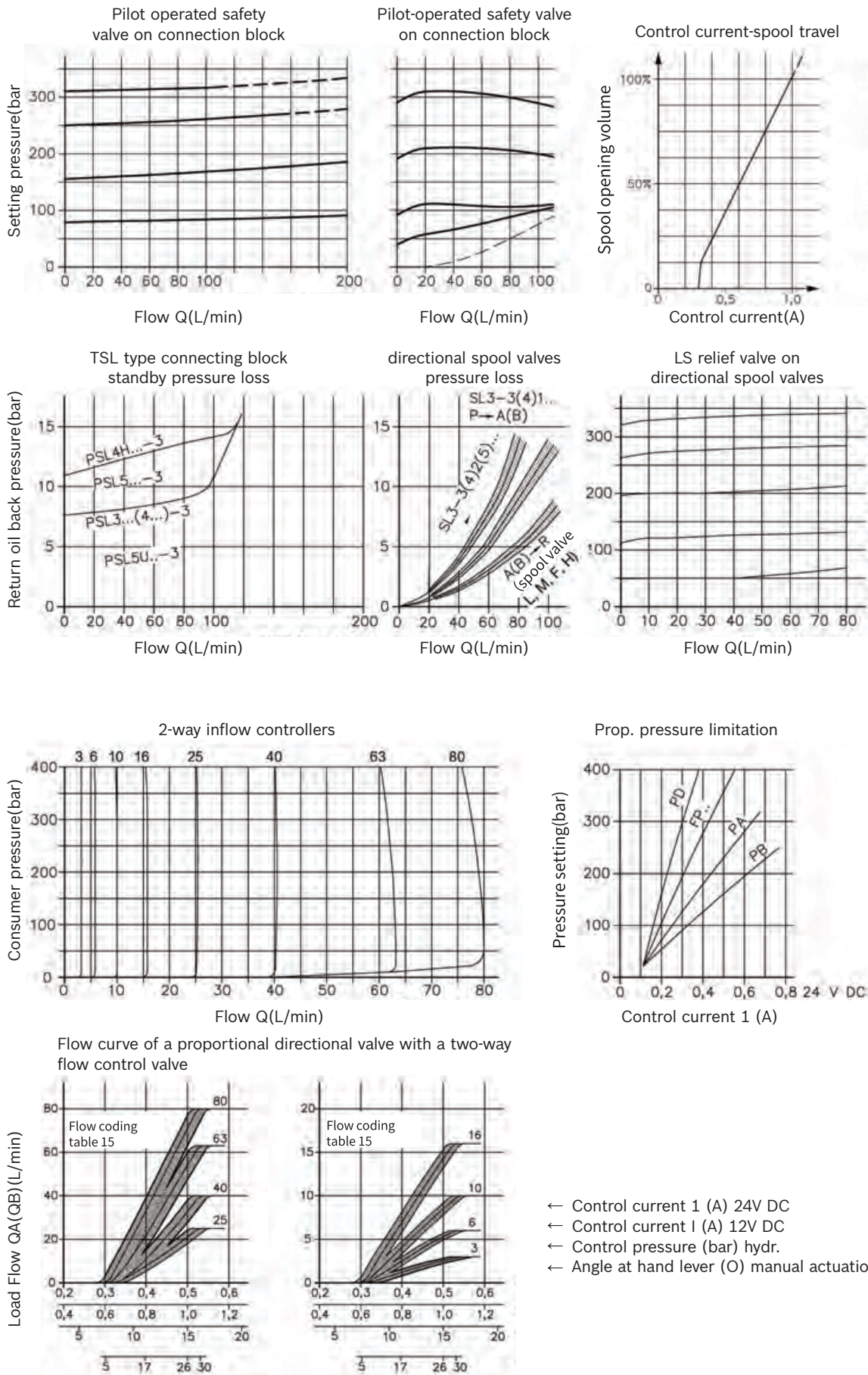

- ← Control current 1 (A) 24V DC
- ← Control current I (A) 12V DC
- ← Control pressure (bar) hydr.
- ← Angle at hand lever (O) manual actuation A. C



Valve curve and parameters

Twine solenoid parameters

Series 3 Proportional directional spool valves use wet type solenoid, the hydraulic oil can enter inside for protection, rust prevention and lubrication, Therefore, no lubrication maintenance is required. Specific parameters are as follows:

Parameters of twin proportional solenoid (control ways: E , EA)

Rated voltage U_N :12VDC

Coil resistance R_{20} :6.7 Ω

Limiting current I_{lim} : 1.26A

Rated voltage U_N :12VDC

Coil resistance R_{20} :27 Ω

Limiting current I_{lim} : 0 . 6 2 A

In order to get better proportional control characteristics, it is recommended to add dither signal to the proportional electromagnet. The parameter setting is as following:

PWM frequency:1K

Dither frequency:40-70Hz Preferably 55Hz

Dither amplitude:20% \leq AD \leq 35%

$$A_D (\%) = \frac{I_{\text{peak-peak}}}{I_G} \cdot 100$$

When there is no dither signal, fine proportional control characteristics can be get by adjusting PWM frequency, PWM frequency : 60-100Hz, Preferably 75Hz

Twin proportional solenoid parameters (For on/off control function)

Rated voltage U_N :12VDC

Coil resistance R_{20} :8.7 Ω

Limiting current I_{lim} : 1.4A

Rated voltage U_N :24VDC

Coil resistance R_{20} :35 Ω

Limiting current I_{lim} : 0.7 A

Additional codes for manipulation methods V,VA,VB,VC

Pin definition

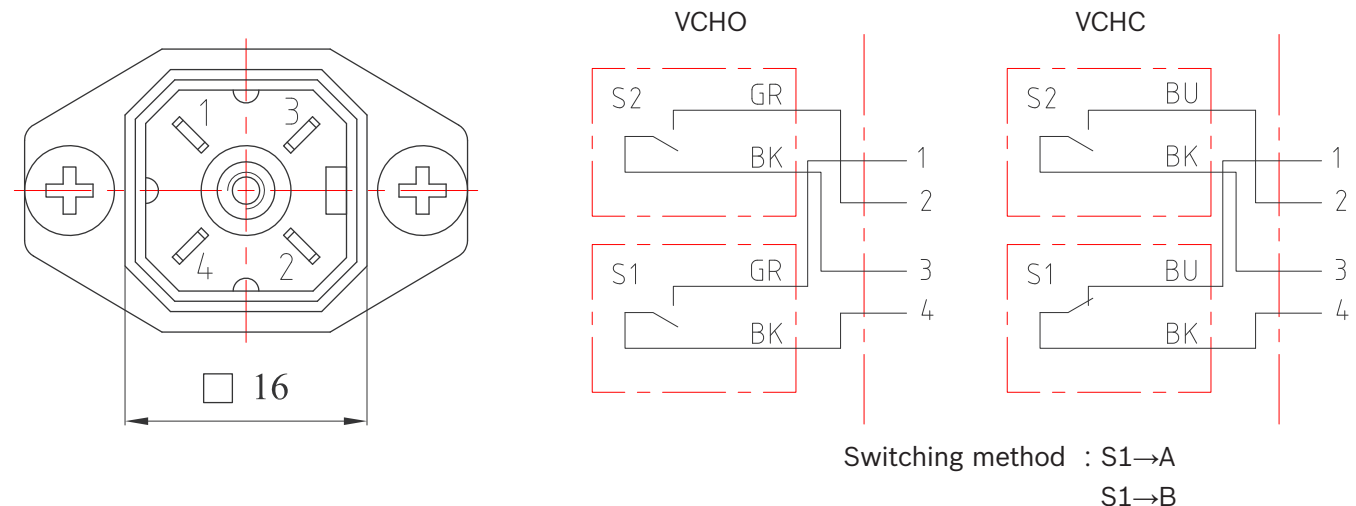



Valve curve and parameters

Double-headed solenoid interface and wiring diagram(3-pin)

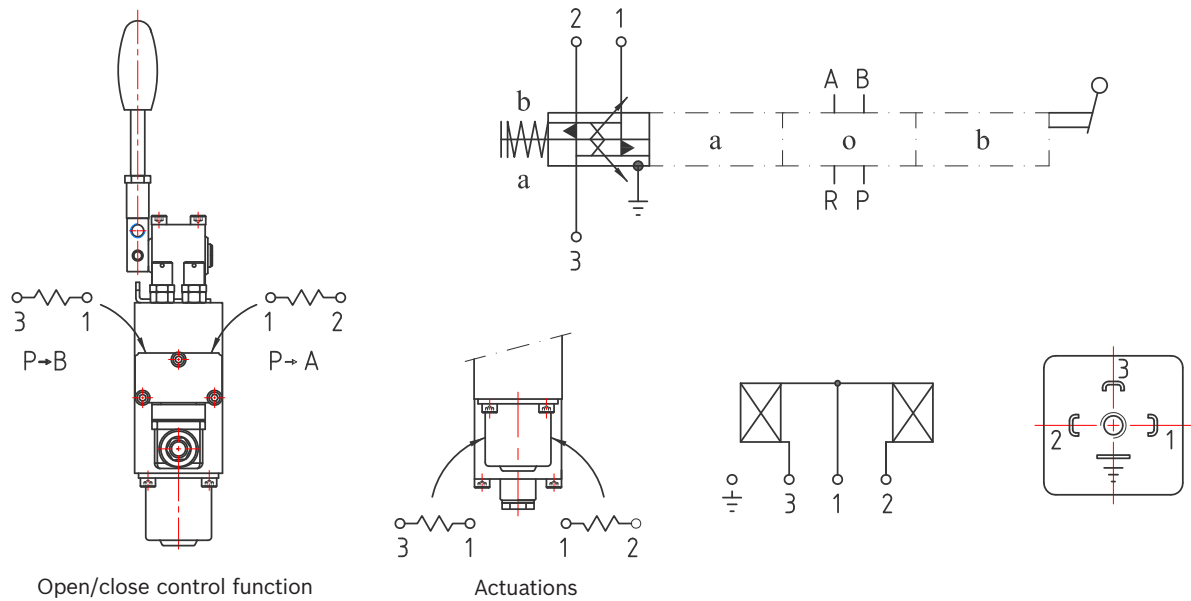

Double-headed solenoid interface and wiring diagram (4-pin)

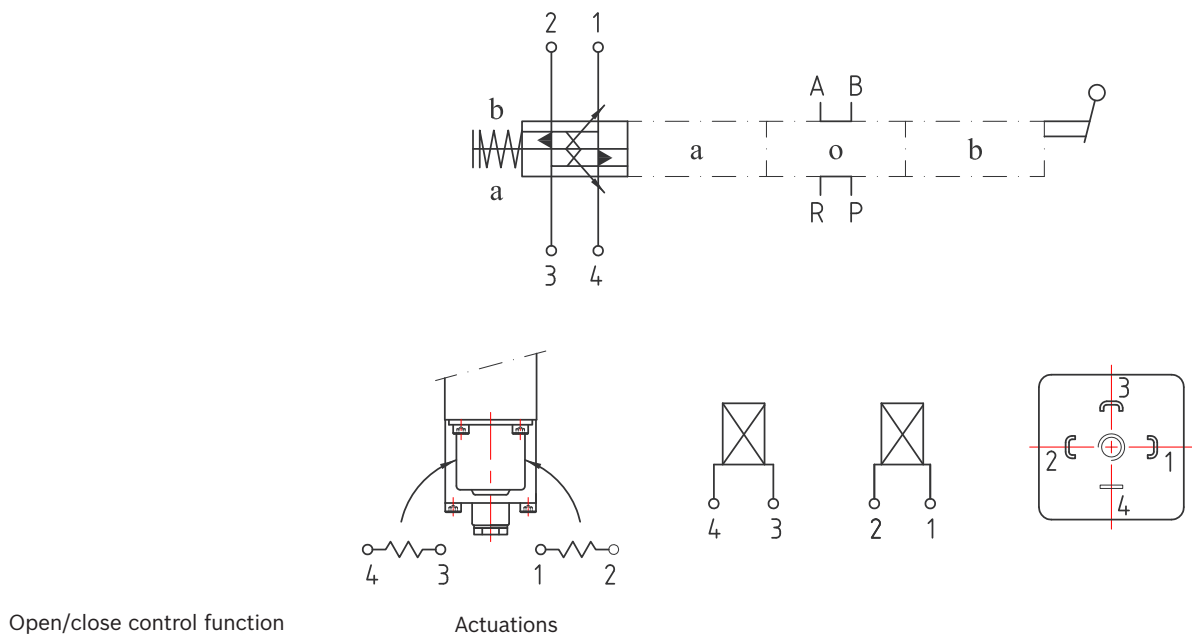

- 1) pin1~3 coils control A position, pin1~2 control B position;
- 2) In 4-pin, 3~4 coils control A position, 1-2 coils control B position
- 3) Double-headed solenoid plug standard DIN 43650A (IS04400)
- 4) Supplied with solenoid for proportional directional spool valves. Waterproof standard connection plug to match the solenoid plug shown on the right



Valve curve and parameters

Port mark and position dimension

Port size

P	Pressure oil inlet	At connection block, series G1/2,G3/4 or G1 The oil port of E17-E20 terminal block is G3/4
R	Return	At connection block, series G1/2,G3/4 or G1 The oil port of E17-E20 terminal block is G3/8
M	Pressure tap for inlet pressure	At connection block, series G1/4
Z	Pilot pressure input/outlet	At connection block, series G1/4
LS/DW	Load pressure tap(TSL)	At connection block, series G1/4
	Load pressure tap(TSV)	At connection block, series G1/4
	Connected to LS (X) port of variable displacement pump(TSV)	At connection block, series G1/4
A/B	Load port	At the directional spool valves, series G1/2 or 3/4
U/W/X	Function cut-off control port	At the directional spool valves, series G1/8
T	Pilot oil return port	At the end plate, series G1/4
Y	Downstream proportional directional spool valves LS oil inlet	At the end plate, series G1/4

Fluid parameters

- 1)Hydraulic oil accuracy should reach GB/T14039-2002 in -/18/15 grade (Equivalent to Level 7 in America NAS1638
- 2)Viscosity range: about 4~1500 cst, optimum viscosity: about 10~500 cst
- 3)Synthetic medium: poly alkyl ethylene glycol (HEPG) and synthetic grease (HEES), operating temperature is about+70 ° C
- 4)Operating oil temperature - 25 ° C~+80 ° C
- 5)Operating ambient temperature - 40 ° C~+80 ° C
- 6)The oil must be maintained according to the actual cleanliness of the hydraulic oil, the filter element of the oil filter must be replaced regularly, and the oil tank and pipeline must be cleaned as necessary



Unit Dimensions

TSL3(4)...and TSL3(4) connection block external dimensions All dimensions in the figure are in mm

TS-PSL3 (4) ...

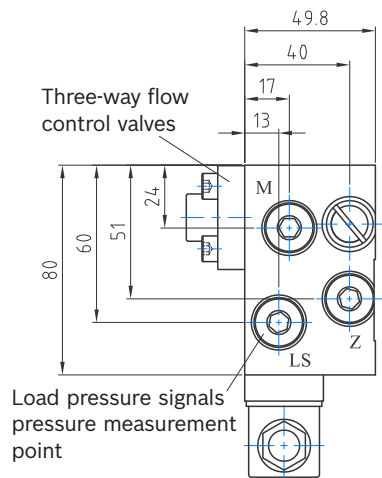

TS-PSL3 (4) Y...

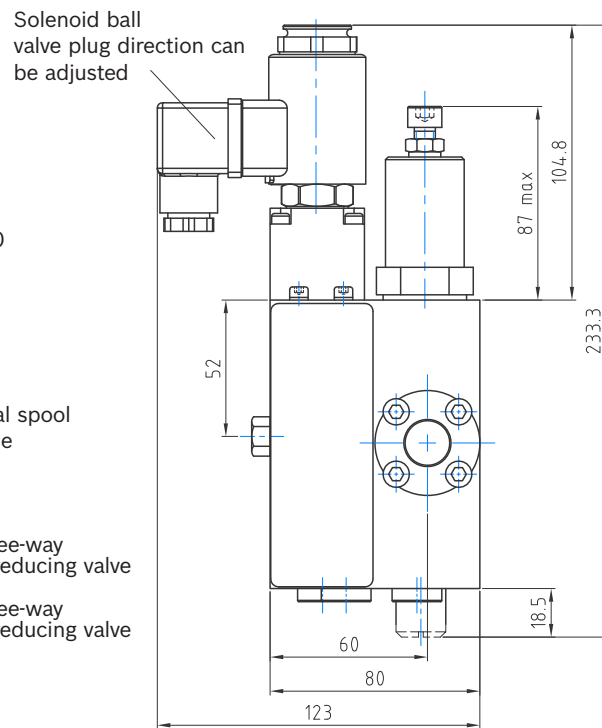
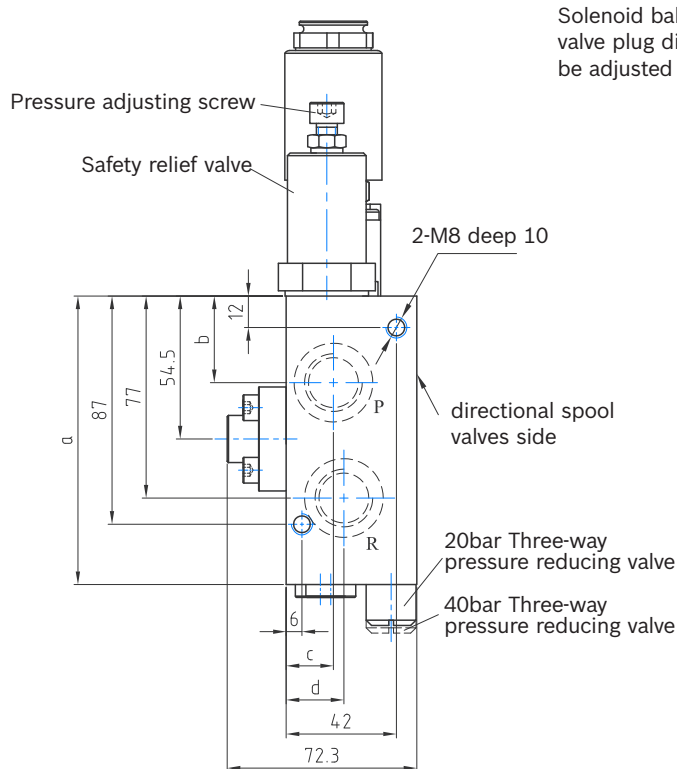
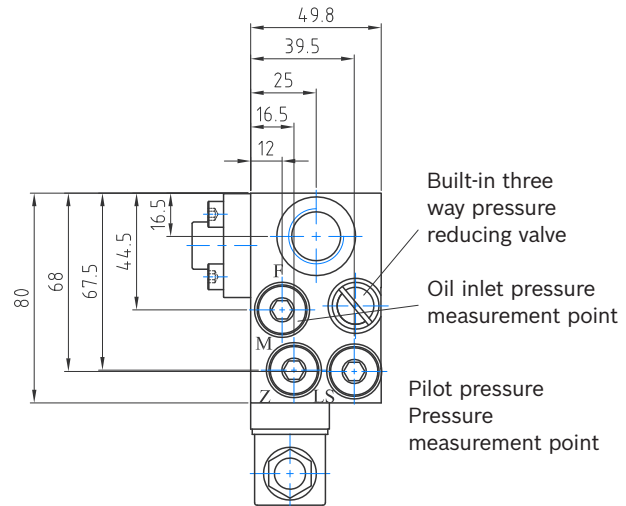

	P	R	LS, Z, M	Standard
TSL 3...	G 1/2	G 1/2	G 1/4	ISO 228/1 (BSPP)
TSL 4...	G 3/4	G 3/4	G 1/4	
TSL 3 Y...	G 1/2	G 1/2	G 1/4	
TSL 4 Y...	G 3/4	G 3/4	G 1/4	

	a	b	c	d
TSL 3...	110	33	18	22
TSL 4...	110	33	21	22
TSL 3 Y...	120	33	18	24
TSL 4 Y...	120	31	21.5	21.5



Unit Dimensions

TSV3(4)...connection block external dimensions

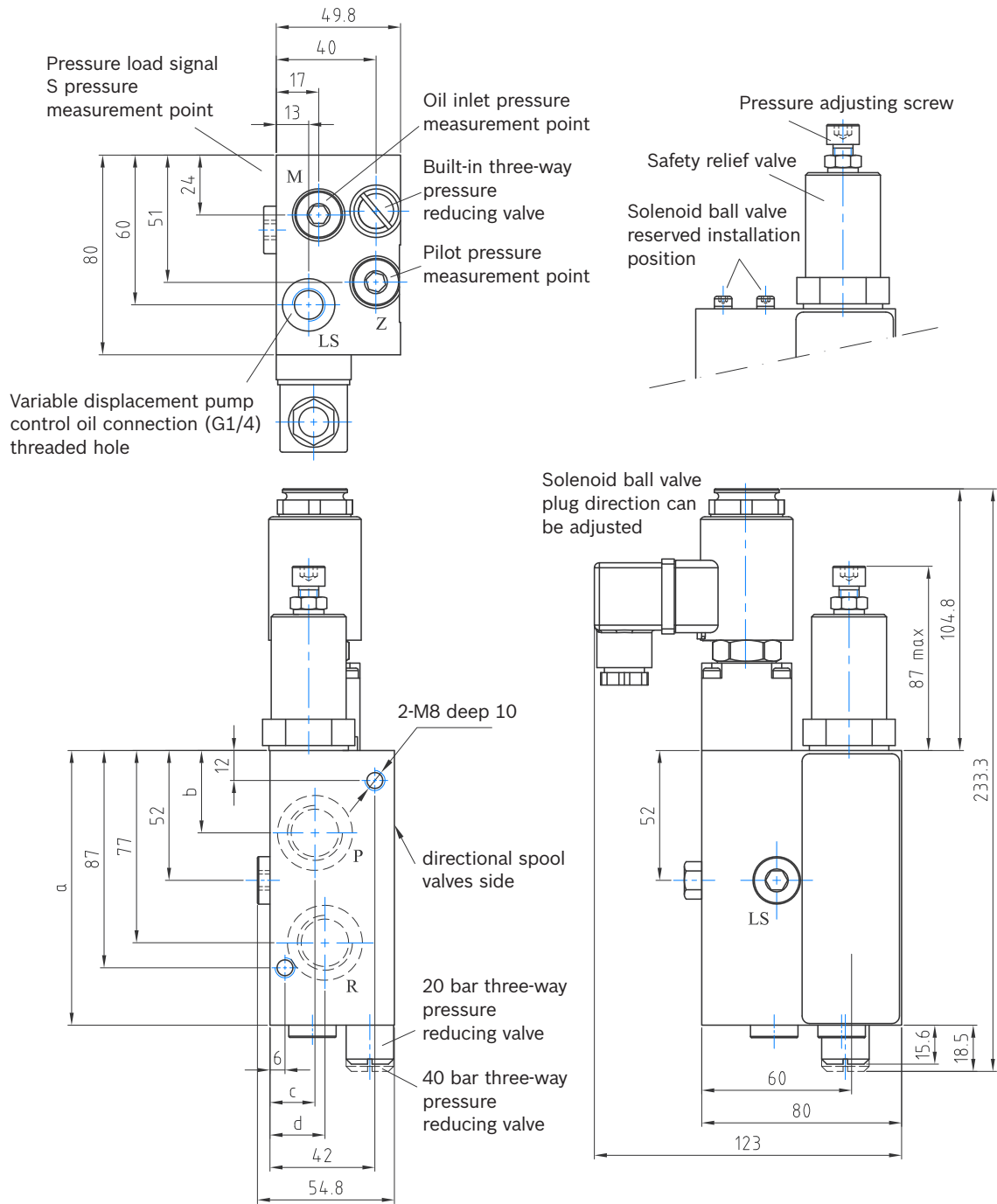

	P	R	LS, Z, M	Standard
TSL 3...	G 1/2	G 1/2	G 1/4	ISO 228/1 (BSPP)
TSL 4...	G 3/4	G 3/4	G 1/4	
TSL 5...	G 1	G 1	G 1/4	

	a	b	c	d
TSL 3...	110	77	18	22
TSL 4...	110	77	21	22
TSL 5...	128	98	21	21



Unit Dimensions

TSL5...,TSL45...,TSL5(UH)...,TSL45(UH)...,TSV55...,TSM5...andTSM5L...connection block external dimensions

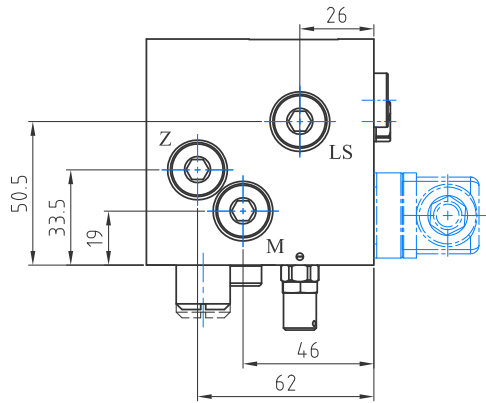

Transition Board	P	R	LS,Z,M	Standard
TSL 45...	G3/4	G1	G1/4	ISO228/1(BSPP)
TSL 45(UH)...	G3/4	G1	G1/4	
TSL 5...	G1	G1	G1/4	
TSL 5(UH)...	G1	G1	G1/4	
TSV 55...	G1	G1	G1/4	
TSM 5...	G1	G1	G1/4	

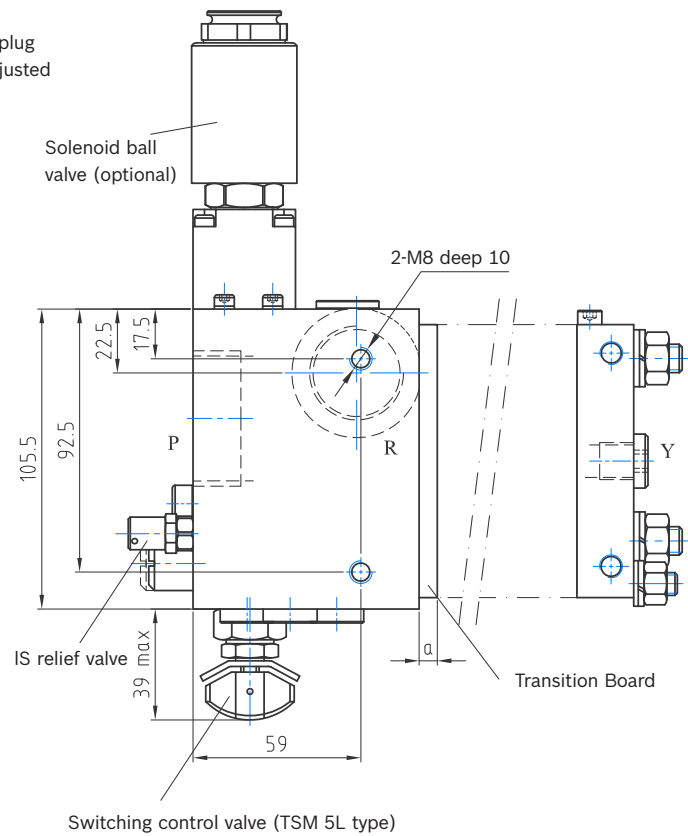
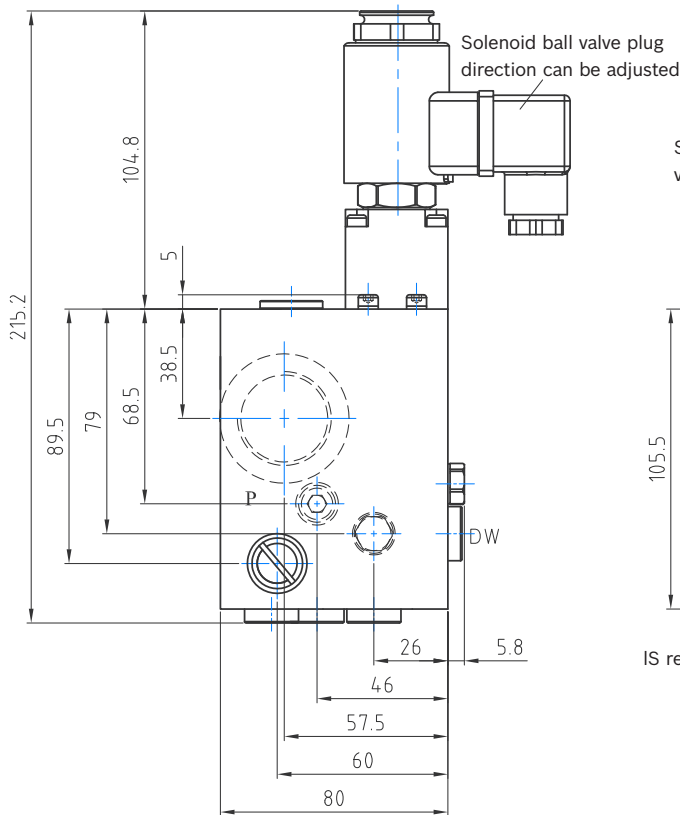

Three-way pressure reducing valve

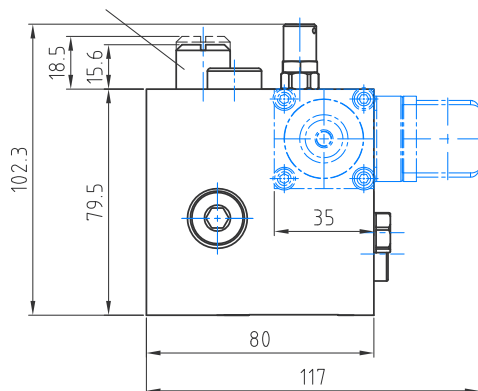

Transition Board	a
ZPL 33/5	5
ZPL 33/15	15
ZPL 33	49.8



Unit Dimensions

A,C type control mode directional spool valves external dimensions

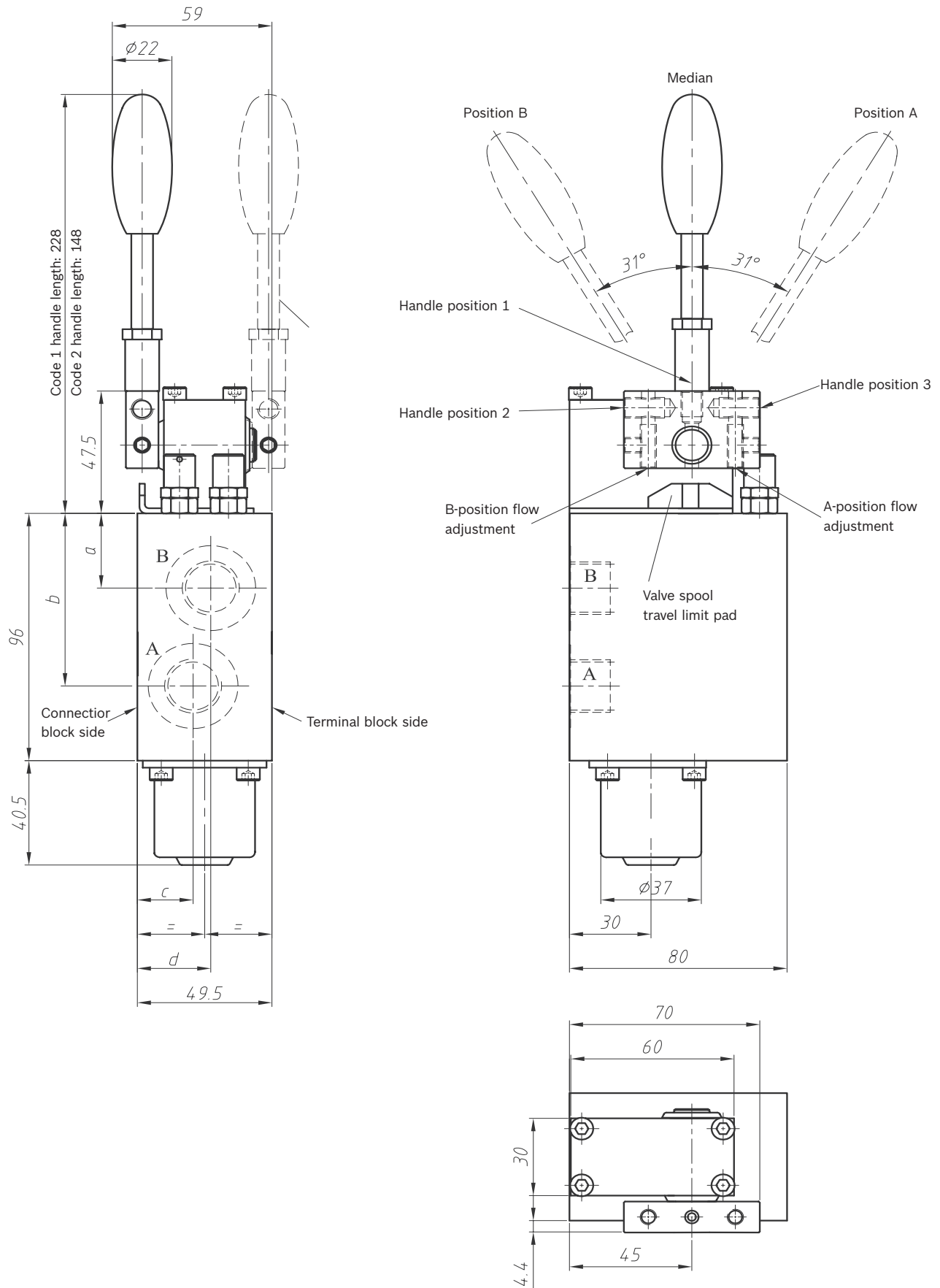



Unit Dimensions

E(T,TH),EA(T,TH),EKA EA type control type directional spool valves external dimensions

EA, EKA Type

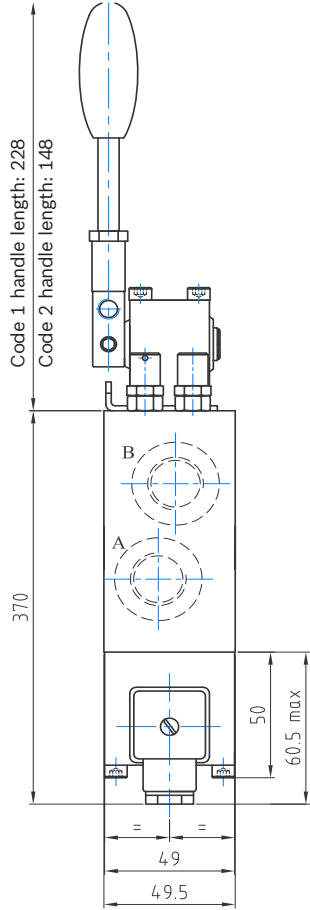

E(EA)/T,E(EA)/TH Type

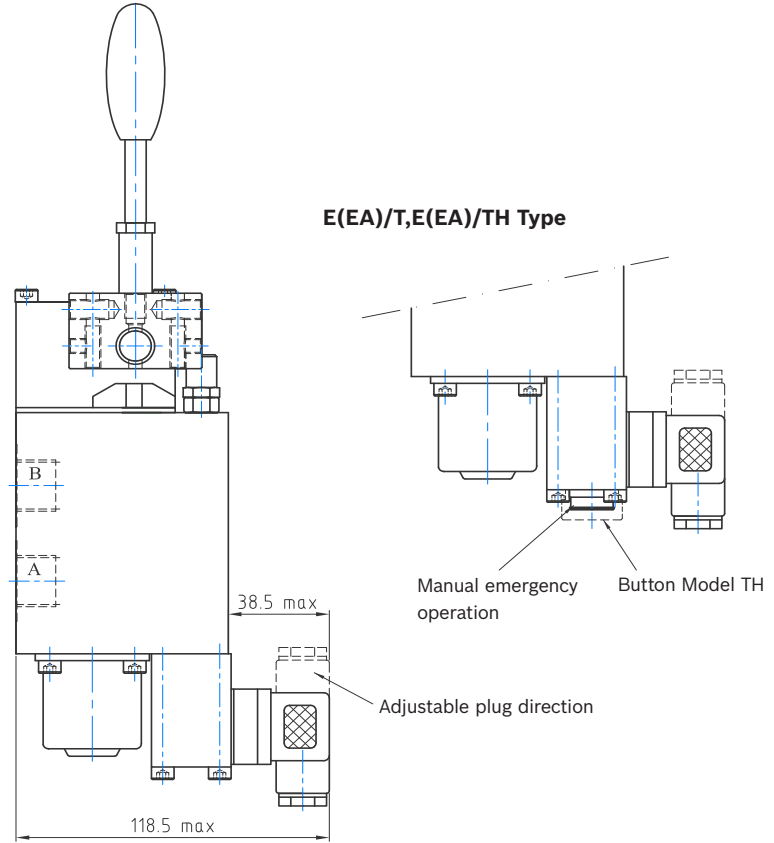

Type E

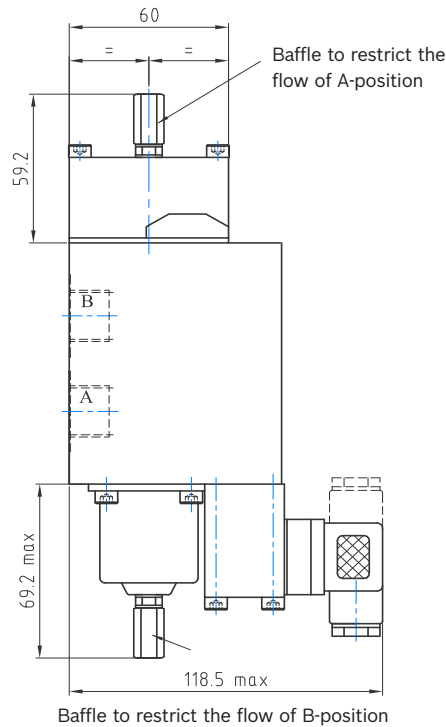
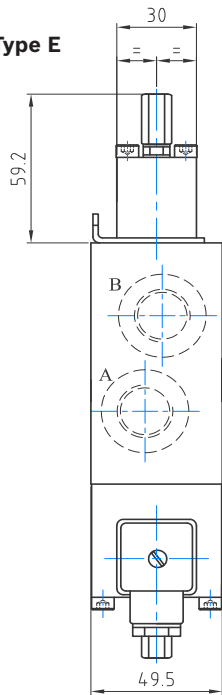



Unit Dimensions

H, HA type control type directional spool valves external dimension

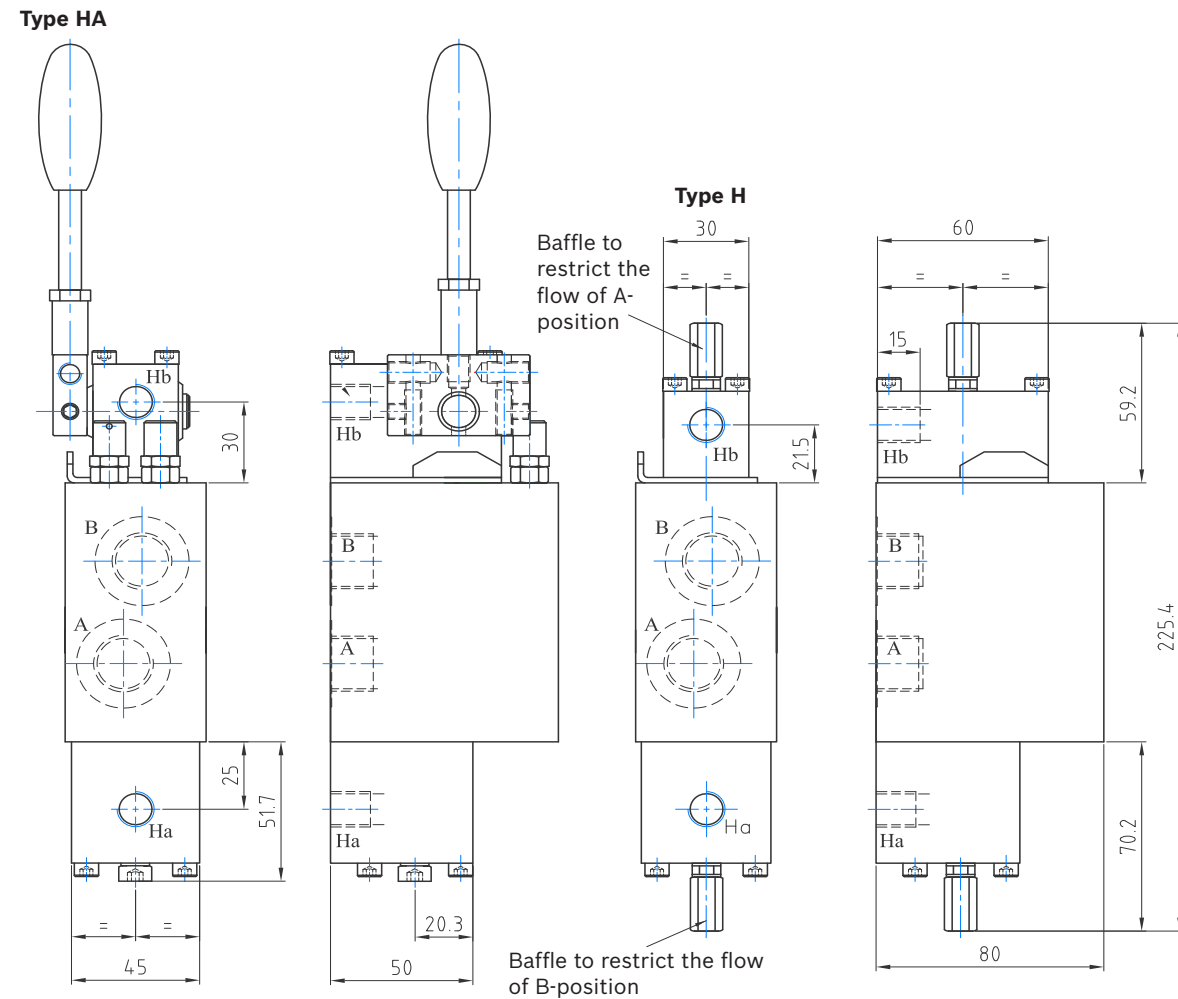

Trip Monitoring

...V(VA,VB,VC)

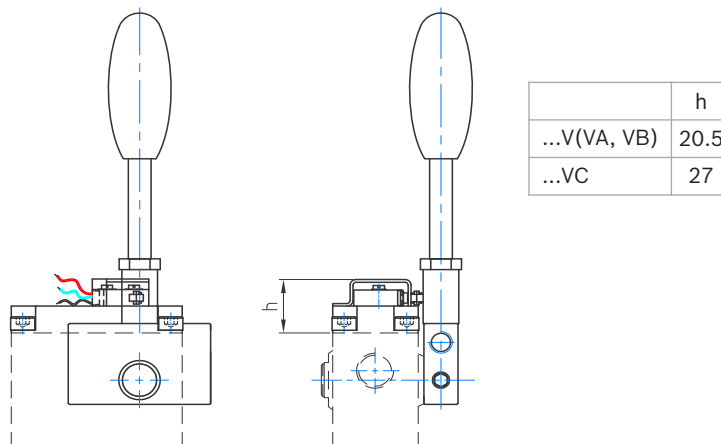

Note: The Ha and Hb ports are the interface for the pilot control of the H-type and HA-type control blocks, respectively, and are connected to the output port of the hydraulic control handle or to the AB port of the THM product electro-hydraulic pilot control module



Unit Dimensions

Dimensions of the directional spool valves with LS restrictor valve, functional shut-off valve and proportional restrictor valve

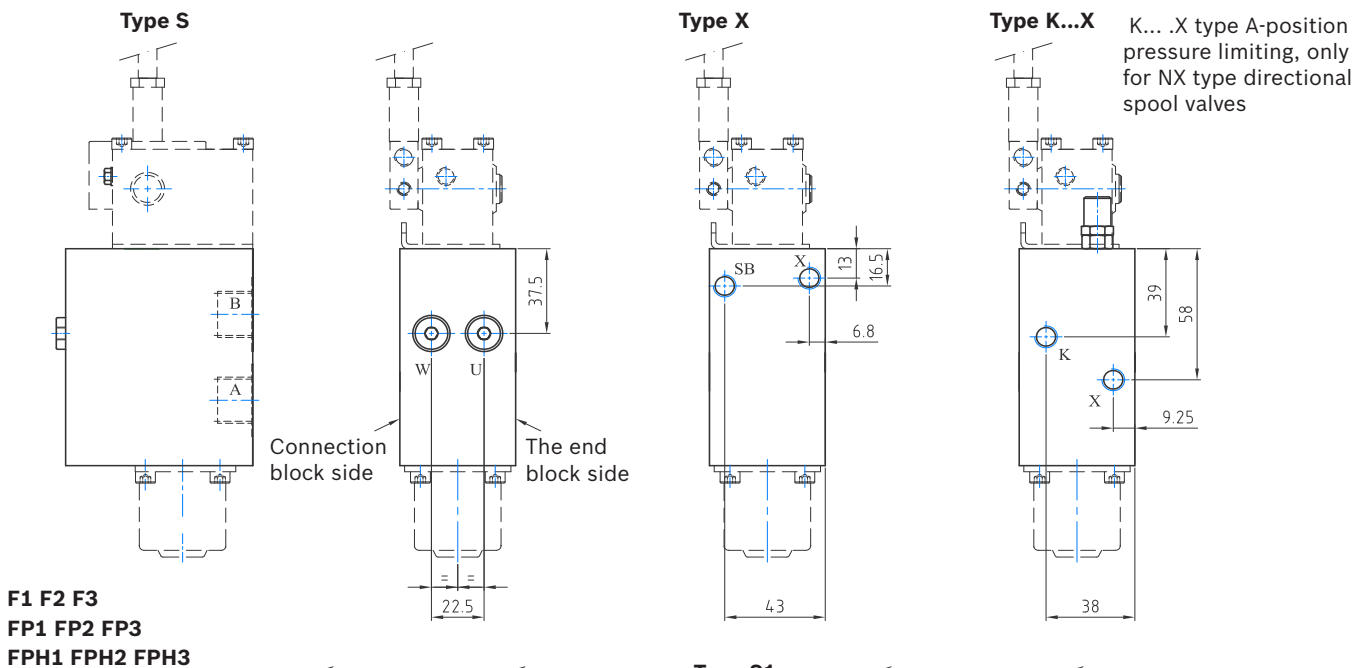
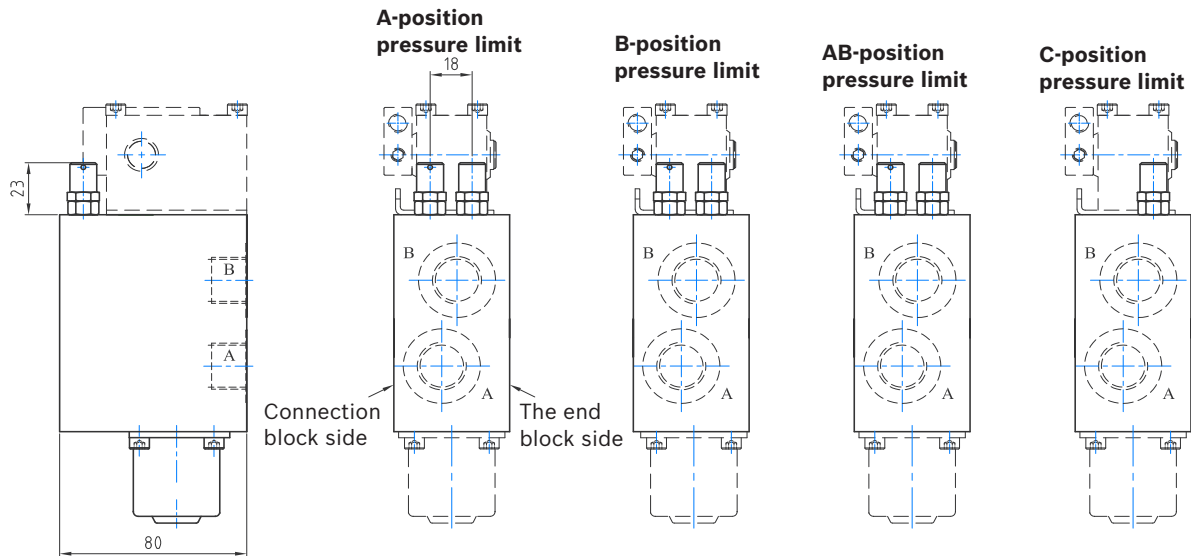

F1 F2 F3
FP1 FP2 FP3
FPH1 FPH2 FPH3

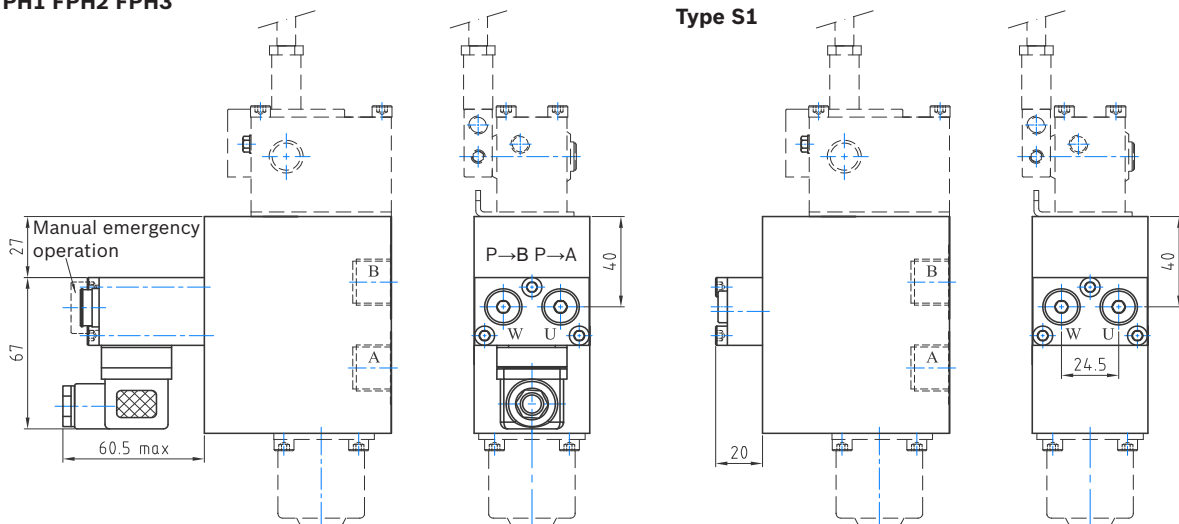



Unit Dimensions

Type E1 E2 E4 E5 end plate external dimensions

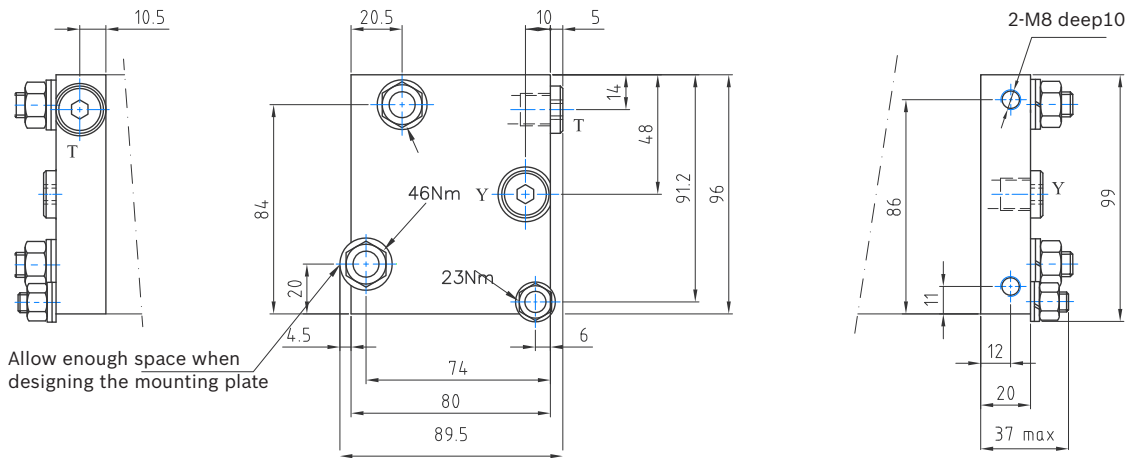

Type E3 E6 end plate external dimensions

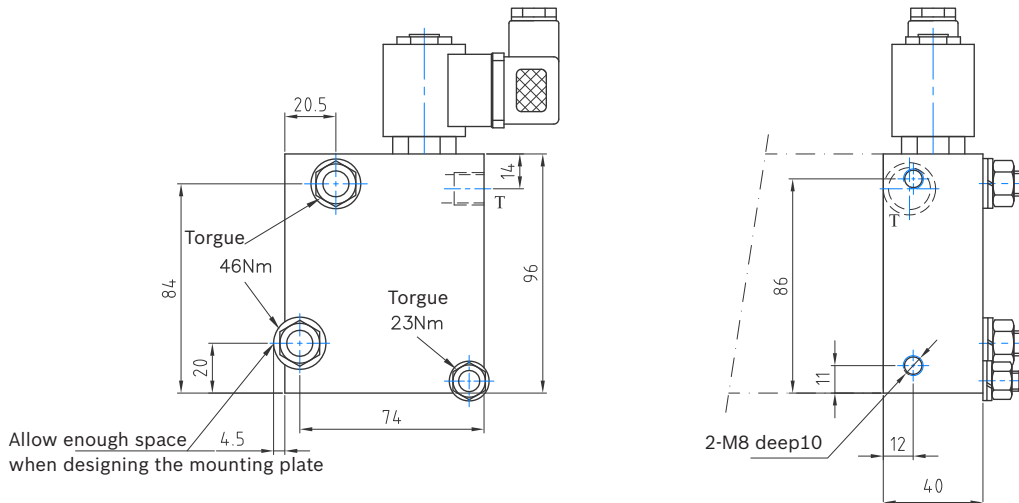

Type E17 E18 E19 E20 end plate external dimensions

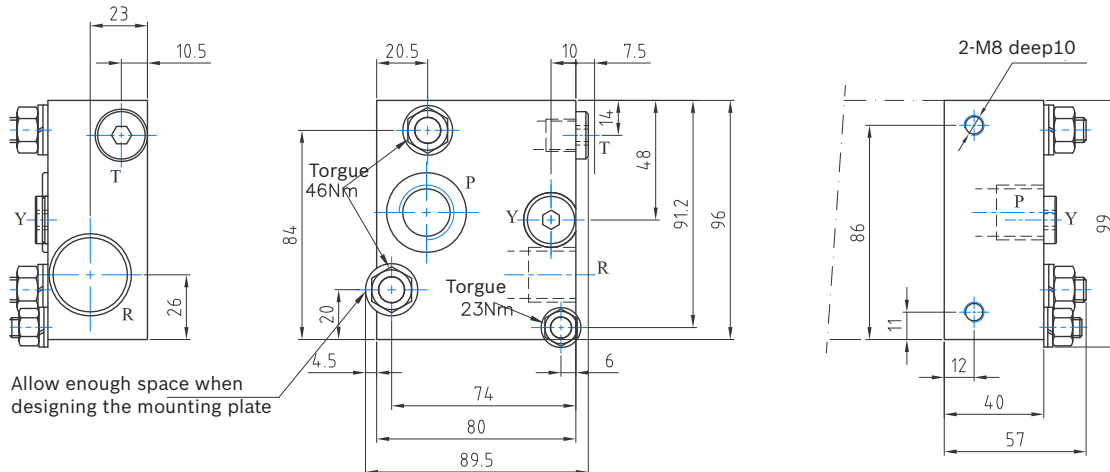

- 1) E1, E2, E3, E17, E18 end plate T-port plug is a plastic plug, the T-port must be connected to the tank when the proportional directional spool valves is taken over, and keep the pipeline open;
- 2) The Y-port of E2, E5, E18 and E20 type tail plate is installed with plastic plug, which must be connected to the LS-port of downstream multi-valve or connected to the tank when installing proportional directional spool valves pipeline;
- 3) E17, E18, E19, E20 type end plate P, R port installed are plastic plugs, if not used, users need to provide their own steel plug ;
- 4) Except for the threaded holes for plastic plugs mentioned in 1) and 2) above, all the threaded holes are sealed with steel plugs and are not removable;



Unit Dimensions

Whole rental proportional directional spool valves shape and installation dimensions

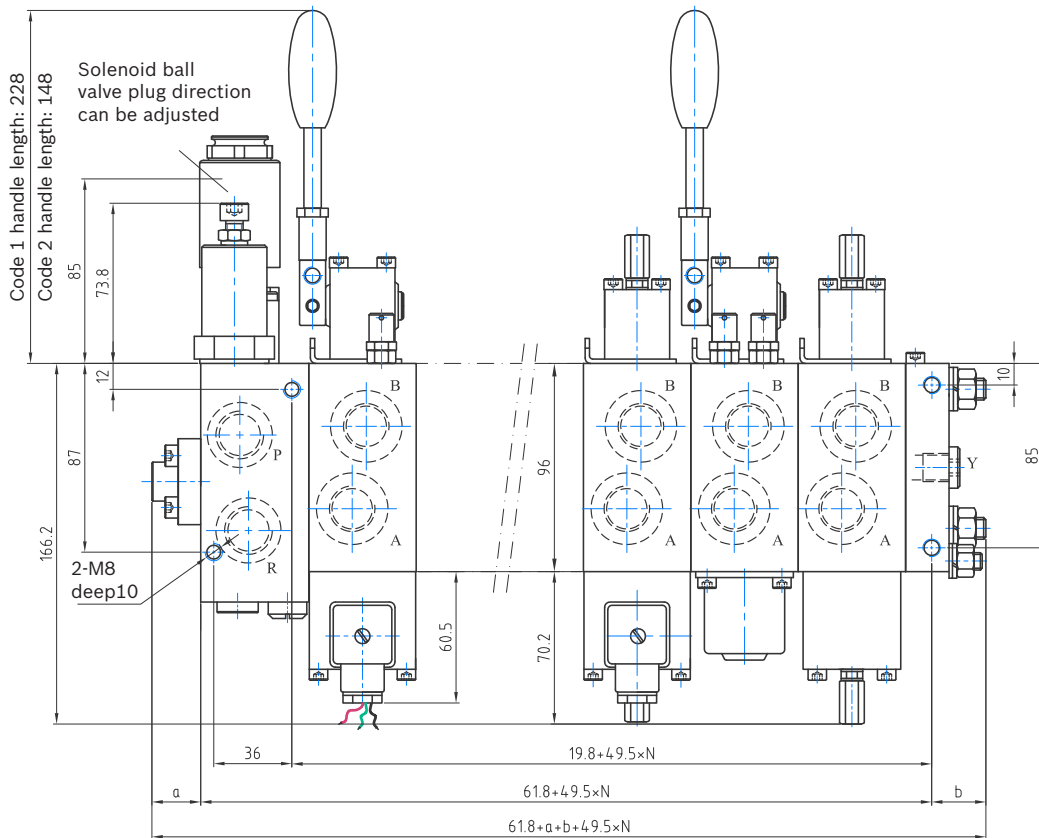

Solenoid ball valve are available as an option

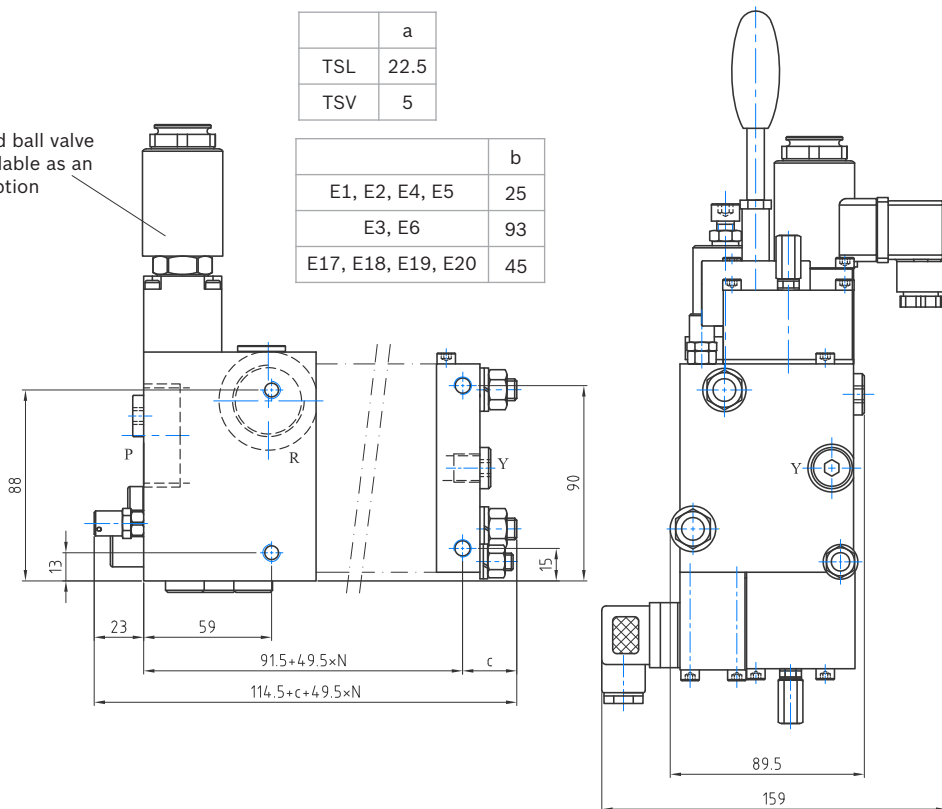



Installation and start-up instructions

Mounting threads: 4 M8 deep 10 threaded holes on the connection block and end block

Installation Series : Ask for Engineering Valves Technical Department of THM Huade Hydraulic

Install the base plate: the base plate should be flat, the valve should not have a twisting force after installation, so as not to distort the valve set to make the spool jammed! ! !

Oil port connection: When connecting, you must pay attention to the letter mark of each oil port, and connect the pipeline strictly according to the requirements of the hydraulic schematic.

P port: Oil inlet port, connected to pump output port

A/B port: working oil port, respectively connected to the two control ports of the cylinder or motor

R port: oil return port, connected to oil tank

M port: pressure gauge interface, measuring the pressure of the inlet of the proportional directional spool valves

LS port: Load pressure feedback signal output port, usually the LS port on the TSV type multi way valve connection block is connected to the X port of the load sensitive pump or to the Y port of the TSL or TSV type proportional directional spool valves with E2 or E20 type tail plate upstream.

Z port: pilot control oil port, when the proportional directional spool valves is in the form of hydraulic control, it can provide pilot pressure oil for the hydraulic control handle

U,W port: the load pressure signal output port on the directional spool valves, connected to the travel limit valve to achieve the travel limit of the actuator

Y port: Load pressure signal input port (E2 or E20 type terminal block only!) usually connected to the LS port on the connection block of the latter TSV type proportional directional spool valves, if not connected to the latter TSV type proportional directional spool valves, it must be connected to the tank; the Y port on the terminal block of E1 or E4 type is plugged with a steel plug and cannot be taken over!

T port: control oil leakage port, E1, E2, E3 type terminal block on the T port must be connected back to the tank, otherwise it will cause proportional directional spool valves reversing function is not normal and damage can not withstand high pressure spring cover and other parts, thus causing oil leakage and other problems! If the user privately blocked the port resulting in proportional directional spool valves leakage.

Piping: All welded pipes must be pickled and phosphated; hoses must be cleaned!

Welding pipeline: When welding pipeline or welding work next to the valve group, all oil ports of the proportional directional spool valves must be sealed, so as to avoid welding slag and other dirt into the proportional directional spool valves, causing unnecessary failure!

Oil temperature -25+80°C

Environmental temperature -40-80°C

Filtration: When the hydraulic oil is added to the tank, it must be filtered according to the requirements, and the filtration accuracy conforms to the international standard ISO 440623/19/16.

Oil cleanliness: must be replaced regularly according to the use of working conditions or the actual cleanliness of the hydraulic oil, and regularly replace the filter element of the oil filter, while the necessary cleaning of the oil tank and pipeline



Installation and start-up instructions

The work that must be checked before starting

Piping connection check: make sure that the piping is correctly connected, pay special attention to the P port and R port do not connect backwards!

Solenoid check: check the socket of the solenoid and the wiring connection before starting the machine for errors

Pipeline inspection: If a pipeline shut-off valve is installed at the inlet and outlet of the pump, the valve must be opened before starting the machine.

Unloading circuit check: After the pump is started, observe the pressure value of the pressure gauge at the pump outlet (M mouth) under the state of relief, if the pump cycle relief pressure is too high (- generally ≤ 10 bar, the valve pressure drop itself is 9 bar), it is possible that the pump discharge or return line back pressure is too high (such as the pipe is too thin, too long, or too many elbows cause excessive local losses, etc.), should consider improving measures to avoid excessive energy consumption to make the system to avoid excessive energy consumption to make the system heat up, resulting in unnecessary failure!

Oil leak check: proportional directional spool valves work, the spring cover, handle seat, directional spool valves piece will have a moist oil seepage, which is due to the proportional directional spool valves factory test not wipe clean the stock oil, in the pressure shock and parts under pressure microscopic tensile deformation and seepage, will not become a drop leak, the system does not have any impact on the work, the proportional directional spool valves does not work will automatically disappear
proportional directional spool valves disassembly: Because of the three series of proportional directional spool valves function, complex structure processing and high precision, generally do not recommend the user to disassemble the valve body. However, for some simple troubleshooting or simple parts replacement (such as O-ring replacement, etc.), after obtaining permission from THM sales or technical engineers, the user can carry out the necessary disassembly work on the proportional directional spool valves. The torque of two M10 nuts is 46Nm, and the torque of one M8 nut is 23Nm.

Assembly site: in order to prevent sand, dust and other dirt into the valve body, the installation should be required in a dust-free, clean indoor site, prohibited in the site or other poor environmental conditions for disassembly and assembly. And require the disassembly of the valve body parts before installation with kerosene for careful cleaning

Transportation after assembly: After cleaning and assembling the proportional directional spool valves, if you do not immediately install the pipeline, you must seal all the oil ports of the proportional directional spool valves to avoid dirt entering the proportional directional spool valves body so that the damping hole is blocked, resulting in abnormal function of the proportional directional spool valves or the spool is stuck and cannot be reversed,

TSL/V-5

Proportional directional
spool valves type serie 5
Pmax = 400 bar
Qmax = 240 lpm



Index

Page No

• Product overview, Ordering code description	43-46
• Valve curve and parameters	47-49
• Port mark and position dimension	50
• Installation and start-up instruction	51
• Unit Dimensions	52-58



Product overview

Load-sensing Proportional directional spool valves types series 3 can be used in constant displacement pump and variable displacement pump hydraulic system. Stepless speed regulation can be carried out on the cylinder or motor by means of electronic control manual and hydraulic control. The output flow is only proportional to the input current signal or handle lever, and the speed is independent of the load, so several actuators can work at different pressure and speed independently until the total required flow rate of the actuator is greater than the maximum flow rate that the pump can provide.

The valve contains three functional blocks: connection block, directional valves and end plate. Each function block has different functions for option.

Maximum of 12 sections in each bank of valve.

Ordering code description

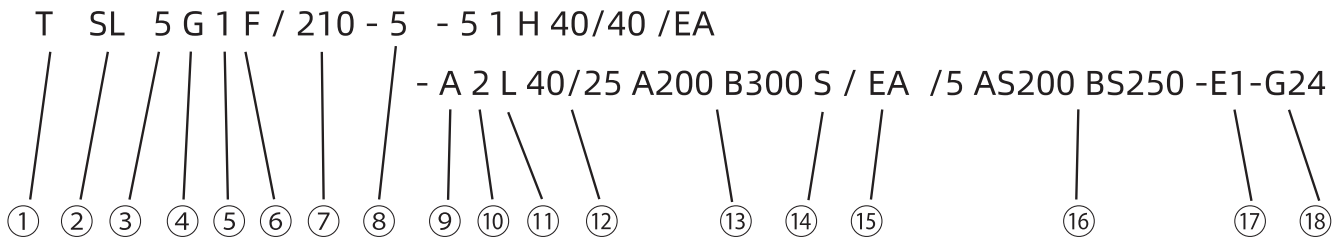

① **TS- THM Huade Hydraulics Pvt Ltd**

② **Connection block type**

TSL Supply with constant delivery pump (open center)

TSV Supply with displacement pump (closed center)

TSM Supply with a constant delivery pump or a variable displacement pump.

ZPL53 Adapter plate enables combination with valve sections series 5

③ **P R ports size (DIN ISO 228/1 BSPP stand)**

5 G1 The maximum flow of the pump is about 250lpm

6 G1 1/4 The maximum flow of the pump is about 300lpm

④ **LS damping elements**

No coding Basic version

In TSL connection block. it is a damping element with integrated check valve, throttle hole and back pressure valve

In TSV connection block. it is a screw plug, no damping effect on the LS oil circuit

S, W Damping element with integrated check valve, throttle and back pressure valve. Code S only available for TSV connection blocks; Code W is like type S, with enhanced throttling effect (type W is not suitable for TSL 4K and TS-PSL4Z)

G It is a combination of damping elements with check valve and throttle, no back pressure valve, so when the system pressure relief LS oil circuit has a strong damping, conducive to system stability (G type is not suitable for TS-PSL4K type, TSL 4Z type and TS-PSL5 type)

B Additional throttle damping in the LS circuit in the TSV only, B (standard throttle diameter Φ 0.8 mm) , B4 (Φ 0.4 mm) , B5 (Φ 0.5 mm) , B6 (Φ 0.6 mm) , B7 (Φ 0.7mm)

Z,K Check throttle valve + unloading valve (TSL type),

H 3-way flow control valve increases the pump circulation pressure (approx. 14 bar, TSL type) and is otherwise identical to the standard type.

U, UH Automatic reduction of pump unloading cycle pressure by means of a bypass valve (TS-PSL5 models only)

Y, YH Only for TSL type connection block, the pressure oil from the outlet of the 3-way flow control valve is output through the power transfer port F on the connection block as the pressure oil source for the downstream hydraulic system.

⑤ **Pilot control oil supply**

No coding No 3-way pressure reducing valve; manual operated valves do not need pilot control oil, or pilot control oil is provided by external pressure reducing valve (pressure range 20~40 bar, flow rate approx. 2 lpm)

1 With 3-way pressure reducing valve, output pressure approx. 20 bar, standard type

2 With 3-way pressure reducing valve, output pressure approx. 40 bar



Ordering code description

⑥ Solenoid Valve for pump unloading

NO coding No solenoid valve, but the installation position is reserved, can be installed at any time

F Normally open type solenoid valve i.e., the pump is unloaded when the valve is de-energized, and the valve bank is in standby state.

D Normally closed solenoid ball valve, i.e., the valve is energized when the pump is unloaded, and the valve bank is in standby state;

F... Normally open valve with pressure limiting valve for secondary pressure limiting (pressure range 50 to 400 bar). The maximum operating pressure of the proportional directional spool valves is the set pressure when the valve is de-energized (e.g. D50, i.e. the maximum operating pressure is 50 bar), and the maximum operating pressure of the proportional directional spool valves is set by the safety relief valve when the valve is de-energized.

D... Normally open solenoid ball valve with pressure limiting valve for secondary pressure limiting (pressure range 50 to 400 bar). The maximum working pressure of the valve is the set pressure when the valve is powered (e.g. D50, i.e. the maximum working pressure is 50 bar), and the maximum working pressure of the valve is set by the safety relief valve when the valve is de-energized.

PA,PB,PD Proportional pressure limiting valves with various pressure ranges are available to limit the maximum L S pressure by means of a proportional relief valve. PA: 10...20 bar; PB: 15...20 bar .20 bar; PB: 15.... .250 bar; PD:18...400bar

⑦ Relief valve pressure setting on the connection block

No coding No safety valve (TSV type connection block only)

/... proportional directional spool valve pressure port P limit pressure to... bar, adjustment range 50~420 bar

⑧ Valve serie

5 series 5

⑨ Port A/B size (DIN ISO 228/1 (BSPP))

5 G1

A directional spool valves with auxiliary block

ZPL55/9 Intermediate transition plate, thickness 9 mm

⑩ Basic directional spool valve unit

1 The directional spool valves without two-way flow control valve can not be installed LS relief valve, used for the working condition without multiple directional spool valves combined action at the same time

2,23,34 The directional spool valves with two-way flow control valve has a control differential pressure of about 6 bar, additional functions such as A/B port pressure limitation and A/B port flow cutoff, and is used for load pressure compensation of several actuators moving at the same time, of which 23 and 24 have additional damping, 23 throttle hole $\phi 0.3$ mm, 24 throttle hole in 0.5 mm

5,53,54 The directional spool valves with two-way flow control valve with a control differential pressure of approx. 9 bar is used to increase the output flow of the reversing block. Can only be used with TSL.... The increased flow rate is shown in the flow rate table in ⑫. The additional damping is available for 53 and 54, 0.3 mm in the 53 orifice and 0.5 mm in the 54 orifice.

8 Pre-selected switching valve is used to switch the up/down oil circuit, so that the on-board and off-board cannot be operated at the same time, which improves the safety and reliability of operation. Only G1/2 threaded interface is available, and only L type spool function is recommended, and it should be used at the maximum flow rate.

⑪ Spool function

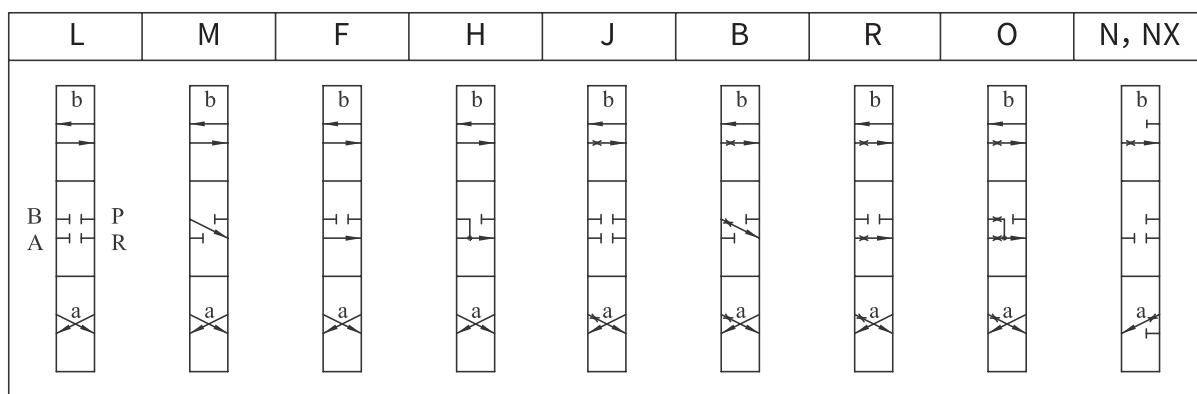



Ordering code description

⑫ Rated flow of port A/B

.../... Rated flow values for ports A and B AB port flow value can be selected symmetrically or asymmetrically

Type of directional valve section block	Type of connection block	Rated flow of A/B port							
		16	25	40	63	80	120	160	
2	TSL or TSV	16	25	40	63	80	120	160	
1	TSL	20	32	51	80	110	150	210	
	TSV	$Q_{AB} = Q_{standard} \times \sqrt{0.2 \times \Delta P_{con}}$							
5	TSL.H. or TSV	20	32	51	80	110	150	210	
7	TSL.H. or TSV	23	37	60	95	130	175	240	
8	TSL or TSV	The directional spool valves has only one output port A, whose flow code is shown in base type 1							

Note: The selected A/B port flow rate can not be much larger than the actual demand flow rate, otherwise, if in the actual use of spool travel limit Rayon to limit the maximum flow rate of A, B port, will directly shorten the flow of the linear control zone length of the directional spool valves so that the proportional control performance of the directional spool valves is reduced. Therefore, it is recommended that the user selects the flow rate is 1.2 times the actual demand flow rate, so that not only to design, commissioning to leave a certain margin, and can better play the proportional control performance of the directional spool valves

Q_{AB} -- One directional spool valves A/B port maximum output flow

$Q_{standard}$ -- Standard flow rates for directional spool valves with two-way flow control valves: See code 2

ΔP_{con} -- Control differential pressure

Note: When the directional spool valves base type is 1 (directional spool valves without two-way flow control valve) TSV type proportional directional spool valves used with load-sensitive variable pump, the output flow rate of the directional spool valves depends on the pressure setting of the load-sensitive variable pump "pressure-flow control valve", as can be seen from the flow formula, the greater the pressure difference, the greater the flow rate, the flow rate value through the table The flow rate value is calculated by the flow rate formula in the table

⑬ A/B port pressure limit

No coding The A/B port has no pressure limit, its maximum working pressure depends on the safety valve on the connection block

A... LS relief valve limits the pressure at port A to... bar (pressure limit range 50 to 400 bar)

B... LS relief valve limits the pressure at port B to... bar (pressure limit range 50 to 400 bar)

C... The LS relief valve limits the pressure at ports A and B to... bar (pressure limit range 50~400 bar), the same maximum pressure for AB port.

A...B... LS relief valves limit the pressure at ports A and B respectively to... bar... bar (pressure limit range 50~400 bar)

⑭ On/off function

No code No on-off function

F1 Output flow from electrical on-off to actuator at port A

F2 Output flow from electrical on-off to actuator at port B

F3 Output flow from electrical on-off to actuator at port A and B

FP1(2 3) Similar to F1 (2,3), but the maximum pressure of A/B port is limited by the electric proportional relief valve

FPH1(2 3) Similar to FP1 (2,3), but with additional buttons for manual emergency operation

S,S1 Through the remote control signal ports U and W, respectively control the flow on and off of ports A and B of the directional spool valve .

X,SB Through the remote control signal oil port X (shared by oil ports A and B) or SB (oil port B), the flow of port A/B of the directional spool valve direction is controlled

⑮ Operation of directional spool valves

/A Manual operation, spring centering and positioning

/C Manual operation, friction positioning (stepless adjustment)

/D Manual operation, card slot positioning (neutral, A,B)

/H Hydraulic proportional operation

/HA Hydraulic control proportion manual operation



Ordering code description

/E Electro hydraulic proportional operation

/EA Electro hydraulic proportion + manual operation

/...Additional 2 No code= standard handle with a length of 150mm;

1=without handle; 2=with short handle 100mm long (suitable for A, EA, HA, C type control mode)

16 Auxiliary block (in combination with code A in , thread port size: /4... G3/4; /5... G1)

/41AS...,BS... The auxiliary block with buffer valve (to the other side) at A and B is marked with pressure (bar)

/4AS...,BS... Auxiliary blocks in A and B with buffer valve and charge valve, marked with pressure (bar)

/4AN...BN... Auxiliary block with buffer valve and makeup valve at A and B, indicating pressure (bar)

/4AN Auxiliary block with buffer valve at port A or B, auxiliary block with charge valve at port B or A, marked with pressure (bar)

/4BN

/3AL...,BL... Auxiliary block with balancing valve at A and/or B, marked with pressure (bar)

/3AL...3BL... Auxiliary block with balancing valve at A and/or B, marked with pressure (bar)

17 End plate

E1 Standard type. The return oil of pilot control oil flows back to the oil tank from the T-port, so the T-port must be connected with the oil tank through a separate external pipeline and the pipeline must be kept smooth, otherwise the pressure holding of the T-port will squeeze the spring cover and deform, resulting in oil leakage or failure to reverse;

E2 As with E1 type end plate, the T-port must be connected with the oil tank by a separate external pipeline. When several groups of proportional directional spool valves are connected in series to share a hydraulic pump, port Y is used to connect the LS port on the downstream proportional directional spool valve connection block; Note that the Y port of a group of multi way valves farthest from the pump must be connected to the oil tank with a separate external pipeline and the pipeline must be kept smooth;

E3 The pilot control oil return must flow from the T port back to the tank. In addition, there is an extra. A solenoid ball valve is used to unload the proportional directional spool valves when all directional spool valves are in the neutral position to build up pressure at the pressure set by its safety valve;

E4 The return oil of pilot control oil flows back to the oil tank through the one-way valve from the R port, without external pipeline, but it must be used under the condition that the back pressure of the return oil R port is less than 10 bar, otherwise the reversing function will be affected during the electric proportional control

E5 Similar to E2, without T interface (like E4)

E6 Similar to E3, without T interface (like E4)

ZPL53 Transition connecting plate for combination with size 3 proportional directional spool valve

End plate		Threaded interface	explain Order code of tailboard as a separate part	for example: SL5-E1 SL5-E6-G24 SL5-ZPL32
External oil return (separate oil return)	Internal control oil return passage			
E1	E4	TY=G1/4 P and R=G3/4	Standard end plate	
E2	E5		With additional oil inlet port Y. e.a. LS control oil pipe for connecting another PSw valve block	
E3	E6		Use WN1H type plate connected 3/2-way shut-off type reversing valve to close the unloading oil circuit of the pump at any time	
			Like E1/E4, but with additional interfaces P and R	
			Like E2/E5, but with additional interfaces P and R	
ZPL53	T = G 1/4		Transition block from size 5 to size 3	

Note: The internal control oil return passage can only be used in the system with the return oil pressure lower than 10 bar

18 Solenoid voltage (see attached diagram on back page for wiring diagram)

G12 12VDC, 3-Pin IP65

G24 24VDC, 3-Pin IP65

G12H4 12VDC, 3-Pin IP65

G24H4 12VDC, 3-Pin IP65

DT12 12V DC electr. Connection via DT04-4P, IP67 plug Co.DEUTSCHDT24

DT24 24V DC electr. Connection via DT04-4P, IP67 plug Co.DEUTSCH

G24EX 24VDC Explosion-proof version Exmb CT4G6

G24MSHA 24VDC Explosion-proof version Exmb IMb



Valve curve and parameters

Pressure limiting valve
Connection block

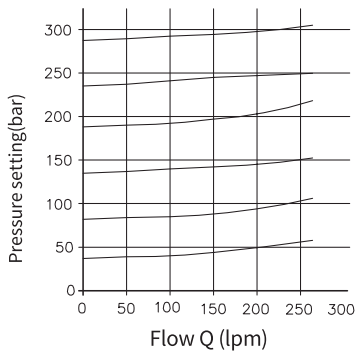

Prop. pressure limitation at the connection block
type TSL (TSV) ..V Z, ZM

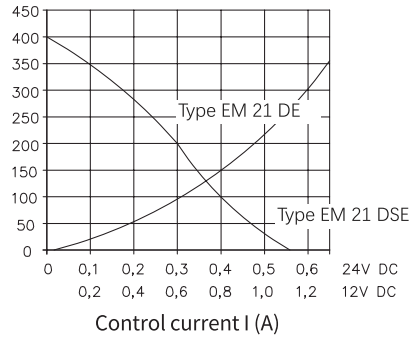

Type TSL: Circulation pressure P R(F)

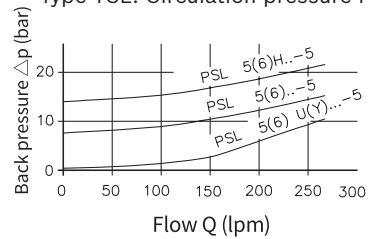

IS relief valve P-O curve

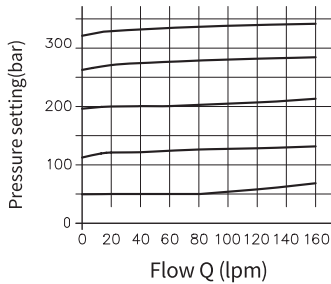

Electric proportional Ls voltage limiting characteristic curve

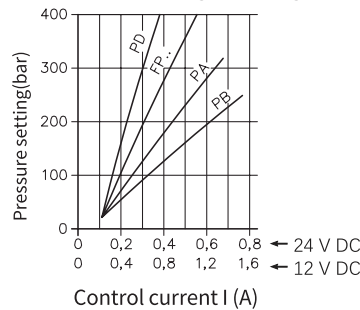

Directional spool valve section
2-way inflow controller

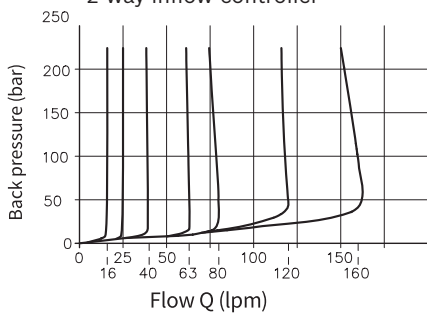

Back pressure(full elevation)

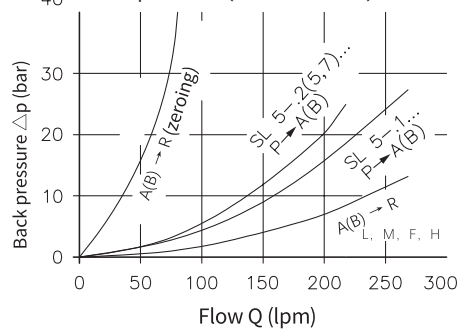

Input / consumer flow curve

(Guideline, example directional spool valve with inflow controller type SL 5-52../..)

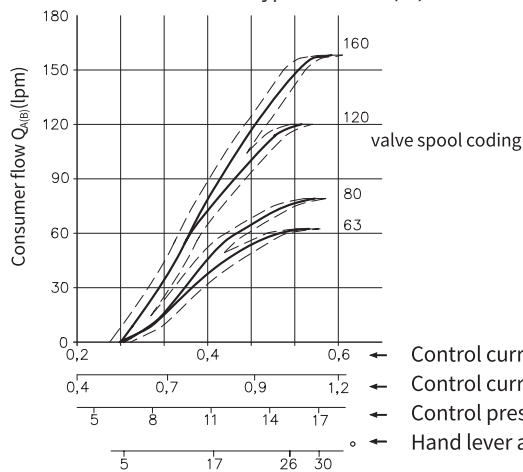
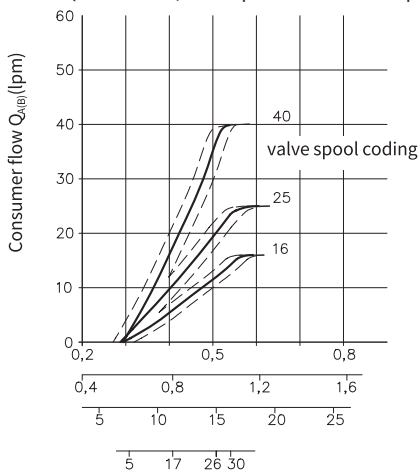

- ← Control current I (A) 24 V DC
- ← Control current I (A) 12 V DC
- ← Control pressure (bar) hydraulic actuation H, HA
- ← Hand lever angel (o) manual actuation A C DHA



Valve curve and parameters

Twin solenoid parameters

Series 3 Proportional directional spool valves use wet type solenoid, the hydraulic oil can enter inside for protection, rust prevention and lubrication, Therefore, no lubrication maintenance is required. Specific parameters are as follows:

Parameters of twin proportional solenoid (control ways: E , EA)

Rated voltage U_N :12VDC

Coil resistance R_{20} :6.7 Ω

Limiting current I_{lim} : 1.26A

Rated voltage U_N :12VDC

Coil resistance R_{20} :27 Ω

Limiting current I_{lim} : 0.62 A

In order to get better proportional control characteristics, it is recommended to add dither signal to the proportional electromagnet. The parameter setting is as following:

PWM frequency:1K

Dither frequency:40-70Hz Preferably 55Hz

Dither amplitude:20% \leq AD \leq 35%

$$A_D (\%) = \frac{I_{\text{peak-peak}}}{I_G} \cdot 100$$

When there is no dither signal, fine proportional control characteristics can be get by adjusting PWM frequency, PWM frequency : 60-100Hz, Preferably 75Hz

Twin proportional solenoid parameters (For on/off control function)

Rated voltage U_N :12VDC

Coil resistance R_{20} :8.7 Ω

Limiting current I_{lim} : 1.4A

Rated voltage U_N :24VDC

Coil resistance R_{20} :35 Ω

Limiting current I_{lim} : 0.7 A

Additional codes for manipulation methods V,VA,VB,VC

Pin definition

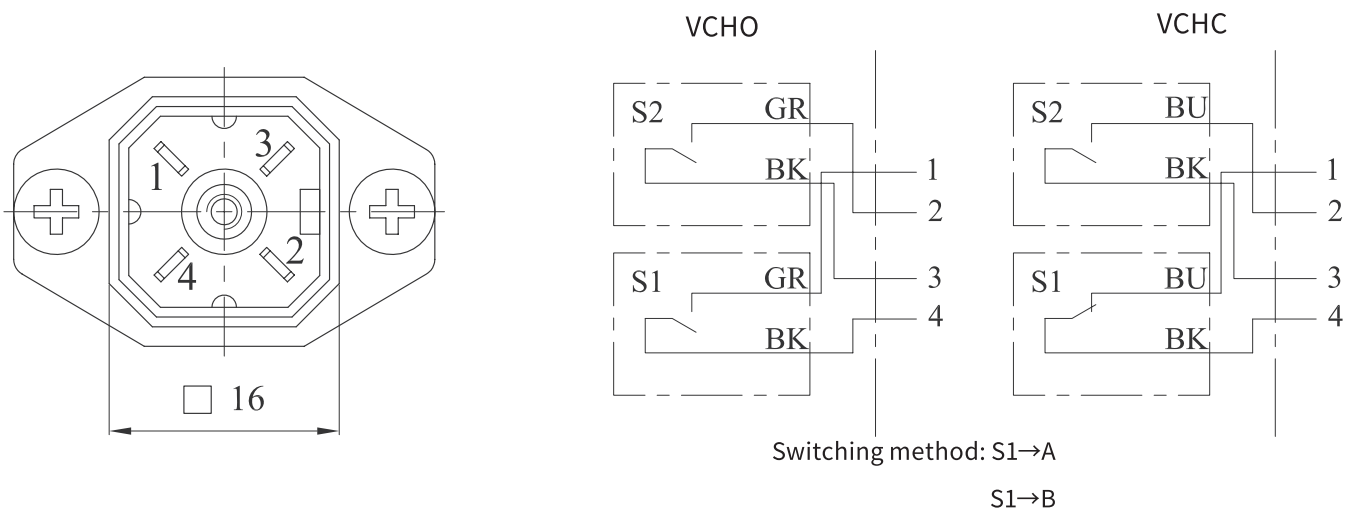



Valve curve and parameters

Double-headed solenoid interface and wiring diagram(3-pin)

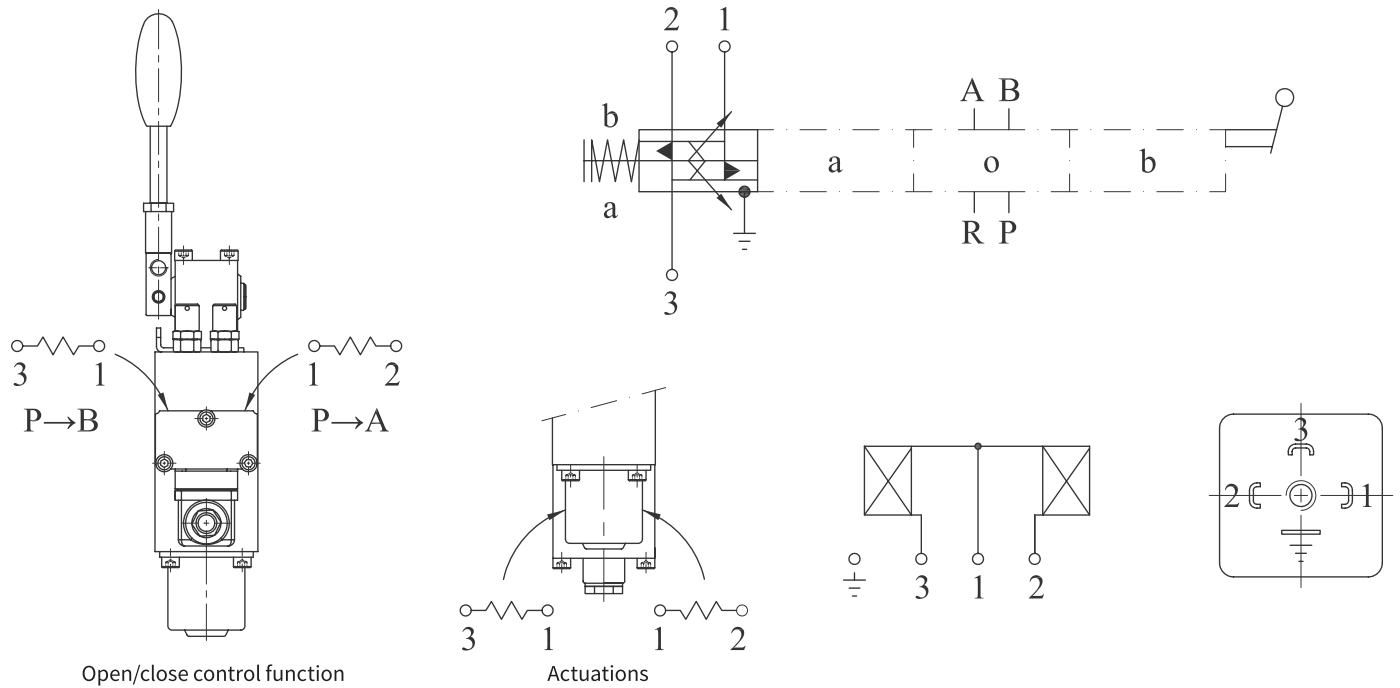

Double-headed solenoid interface and wiring diagram(4-pin)

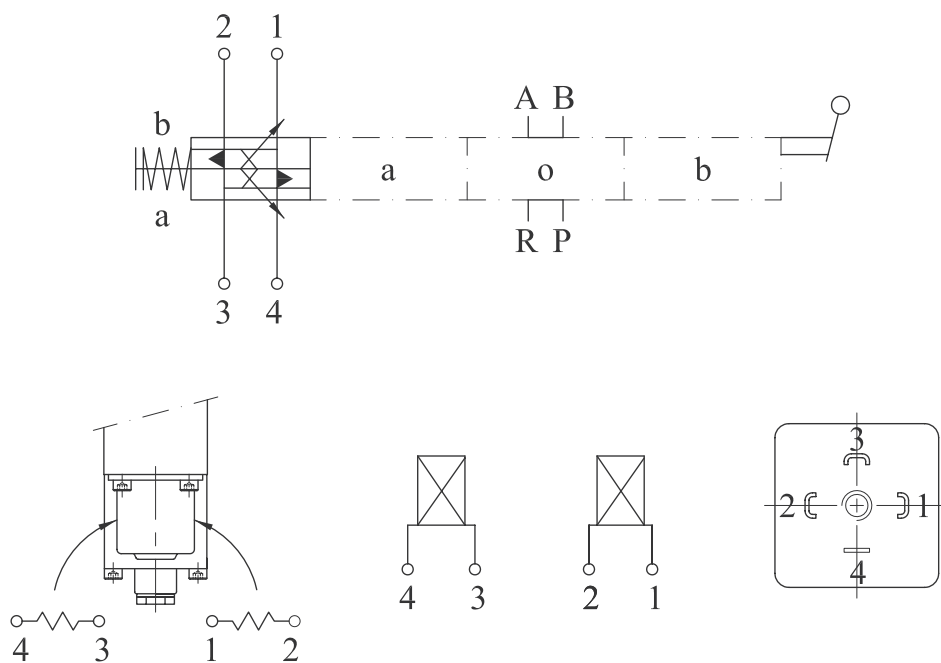

- 1) pin1~3 coils control A position, pin1~2 control B position;
- 2) In 4-pin, 3~4 coils control A position, 1-2 coils control B position
- 3) Double-headed solenoid plug standard DIN 43650A (ISO4400)
- 4) Supplied with solenoid for proportional directional spool valves. Waterproof standard connection plug to match the solenoid plug shown on the right



Port mark and position dimension

Port size

P	Pressure oil inlet	At connection block, size G1 · G1 1 1/4
R	Return	At connection block, size G1, G1 1 1/4
M	Pressure tap for inlet pressure	At connection block, size G1/4
Z	Pilot pressure input/outlet	At connection block, size G1/4
LS/DW	Load pressure tap(TSL)	At connection block, size G1/4
	Load pressure tap(TSV)	At connection block, size G1/4
	Connected to LS (X) port of variable displacement pump(TSV)	At connection block, size G1/4
A/B	Load port	At the directional spool valves, size G1 or 3/4
U/W/X	Function cut-off control port	At the directional spool valves, size G1/8
T	Pilot oil return port	At the end plate, size G1/4
Y	Downstream proportional directional spool valves LS oil inlet	At the end plate, size G1/4

Fluid parameters

- 1)Hydraulic oil accuracy should reach GB/T14039-2002 in -/18/15 grade (Equivalent to Level 7 in America NAS1638
- 2)Viscosity range: about 4~1500 cst, optimum viscosity: about 10~500 cst
- 3)Synthetic medium: poly alkyl ethylene glycol (HEPG) and synthetic grease (HEES), operating temperature is about+70 ° C
- 4)Operating oil temperature - 25 ° C~+80 ° C
- 5)Operating ambient temperature - 40 ° C~+80 ° C
- 6)The oil must be maintained according to the actual cleanliness of the hydraulic oil, the filter element of the oil filter must be replaced regularly, and the oil tank and pipeline must be cleaned as necessary



Installation and start-up instruction

Mounting threads: 4 M8 deep 10 threaded holes on the connection block and end block

Installation Size : Ask for Engineering Valves Technical Department of Shanghai Norma Hydraulic Systems Co.

Install the base plate: the base plate should be flat, the valve should not have a twisting force after installation, so as not to distort the valve set to make the spool jammed! ! !

Oil port connection: When connecting, you must pay attention to the letter mark of each oil port, and connect the pipeline strictly according to the requirements of the hydraulic schematic.

P port: Oil inlet port, connected to pump output port

A/B port: working oil port, respectively connected to the two control ports of the cylinder or motor

R port: oil return port, connected to oil tank

M port: pressure gauge interface, measuring the pressure of the inlet of the proportional directional spool valves

LS port: Load pressure feedback signal output port, usually the LS port on the TSV type multi way valve connection block is connected to the X port of the load sensitive pump or to the Y port of the TSL or TSV type proportional directional spool valves with E2 or E20 type tail plate upstream.

Z port: pilot control oil port, when the proportional directional spool valves is in the form of hydraulic control, it can provide pilot pressure oil for the hydraulic control handle

U, W port: the load pressure signal output port on the directional spool valves, connected to the travel limit valve to achieve the travel limit of the actuator

Y port: Load pressure signal input port (E2 or E20 type terminal block only!) usually connected to the LS port on the connection block of the latter TSV type proportional directional spool valves, if not connected to the latter TSV type proportional directional spool valves, it must be connected to the tank; the Y port on the terminal block of E1 or E4 type is plugged with a steel plug and cannot be taken over!

T port: control oil leakage port, E1, E2, E3 type terminal block on the T port must be connected back to the tank, otherwise it will cause proportional directional spool valves reversing function is not normal and damage can not withstand high pressure spring cover and other parts, thus causing oil leakage and other problems! If the user privately blocked the port resulting in proportional directional spool valves leakage.

Piping: All welded pipes must be pickled and phosphated; hoses must be cleaned!

Welding pipeline: When welding pipeline or welding work next to the valve group, all oil ports of the proportional directional spool valves must be sealed, so as to avoid welding slag and other dirt into the proportional directional spool valves, causing unnecessary failure!



Unit Dimensions

Connection block circuit

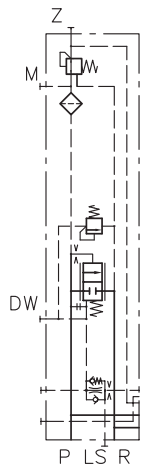

TSL 5(6)1./-5

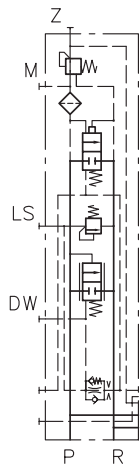

TSL 5.1./-5

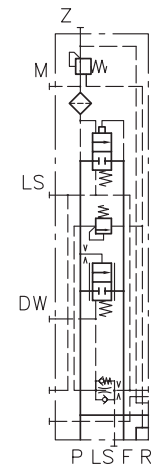

TSV 5(6)1./-5

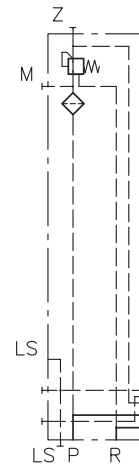

TSV 5(6)1./-5

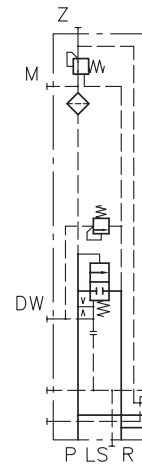

TSV 55.1./-5

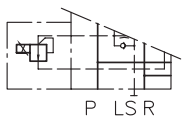

TSL(V)...PA(PB, PD)

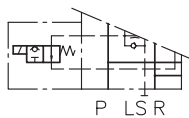

TSL(V)...F
TSL(V)...Z
TSL(V)...ZM

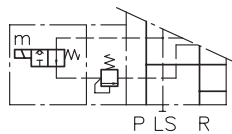

TSL(V)...F..

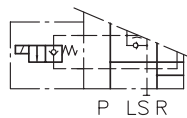

TSL(V)...D
TSL(V)...V

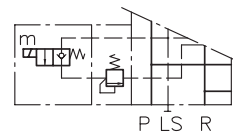

TSL(V)...D..

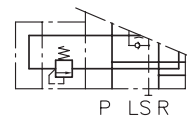

TSL(V)...X

The end plate circuit

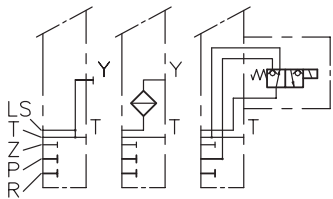

E 1 E 2 E 3

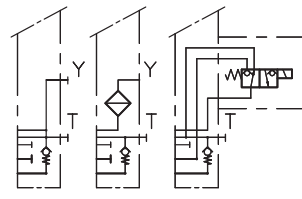

E 4 E 5 E 6

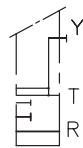

E 7

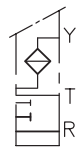

E 8

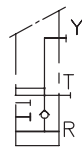

E 9

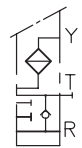

E 10

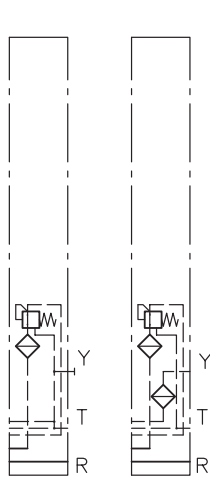

E 7 A 1 E 8 A 1

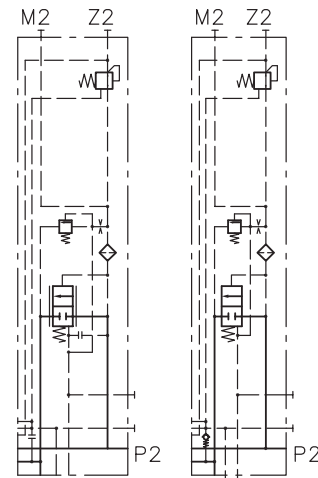

E 1 TSL 56 E 4 TSV 56

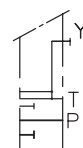

E 13



E 14



E 15

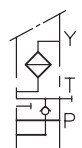

E 16



ZPL 53



ZPL 53 RB



Unit Dimensions

directional spool valves circuit

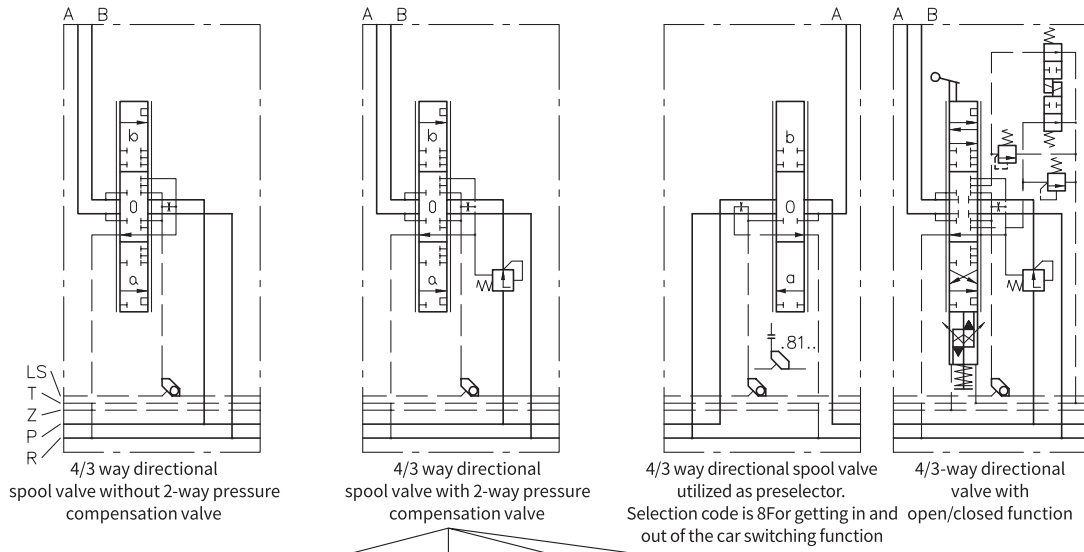

directional spool valves with 2-way pressure compensation valve function available with LS pressure limiting valve

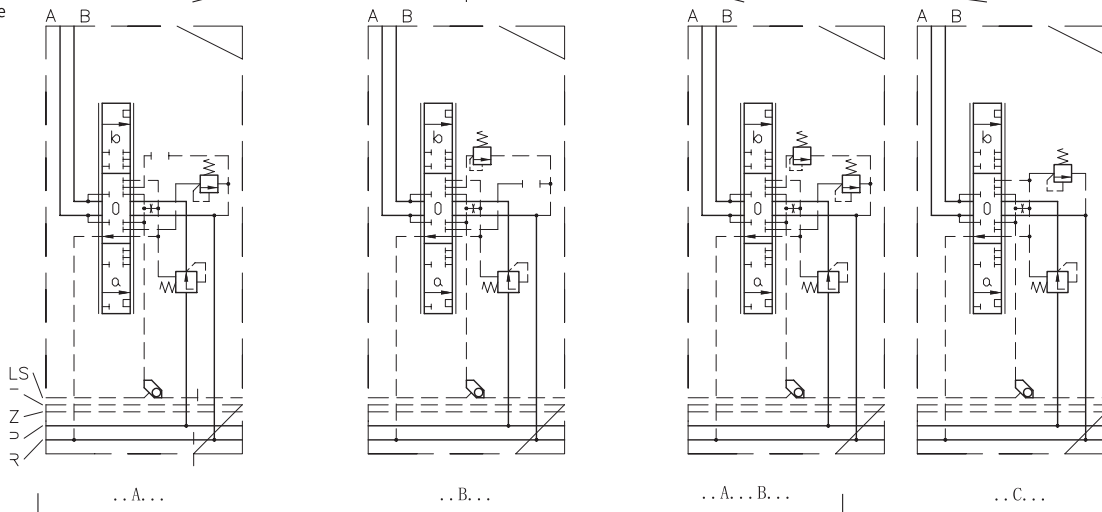

directional spool valves with open break function

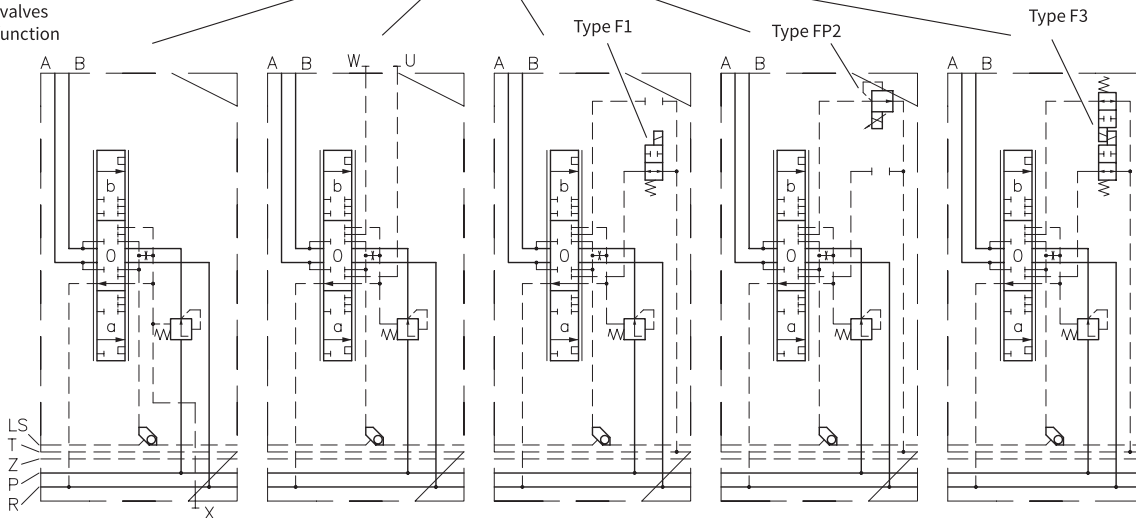

Possible combinations:

.. X	.. S (S 1)	.. F 1, FP 1, FPH 1 (X)	.. F 2, FP 2, FPH 2 (X)	.. F 3, FP 3, FPH 3 (X)
A.. X	A.. S	A.. F 1, FP 1, FPH 1 (X)	A.. F 2, FP 2, FPH 2 (X)	A.. F 3, FP 3, FPH 3 (X)
B.. X	B.. S	B.. F 1, FP 1, FPH 1 (X)	B.. F 2, FP 2, FPH 2 (X)	B.. F 3, FP 3, FPH 3 (X)
A..B.. X	A..B.. S	A..B.. F 1, FP 1, FPH 1 (X)	A..B.. F 2, FP 2, FPH 2 (X)	A..B.. F 3, FP 3, FPH 3 (X)



Unit Dimensions

Connection block type TSL 5(6) U.. (F,D)/..-5 TSL5(6) UH.. (F,D)/..-5

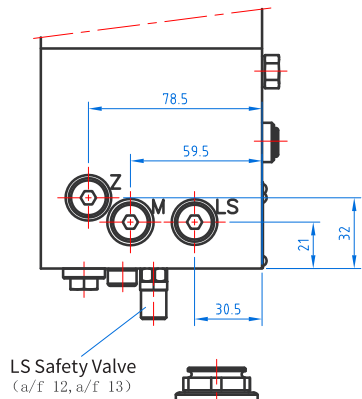

LS Safety Valve
(a/f 12, a/f 13)

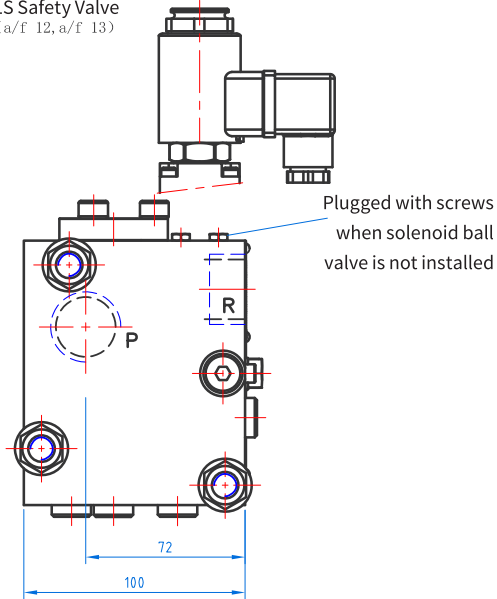

connection block type TSL 6 Y.. (F,D) /..5
TSL 6 YH.. (F,D) /..5

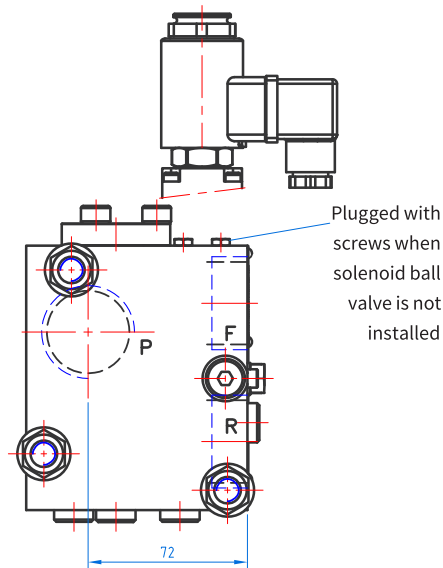

Thread standard ISO 228/1 (BSPP):

P,R =G1 1/4 (TSV 5..)

=G1 1/4 (TSV 6..)

M,LS,Z =G1 1/4

	a	b
TSL 5 U	22	75.5
TSL 6 U	26	74

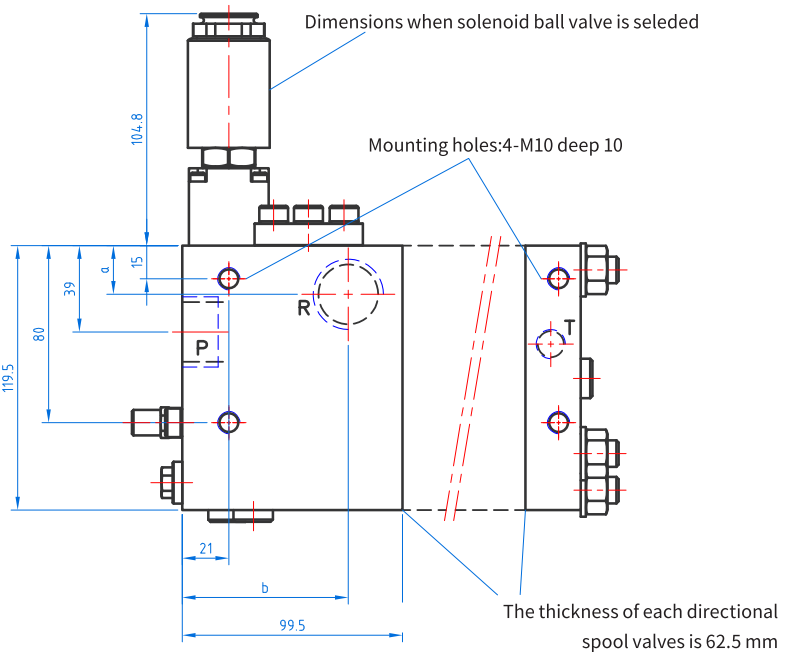

Thread ISO 228/1 (BSPP):

P,R,F =G1 (TSV 5..)

M,LS,Z =G1 1/4 (PSV6..)

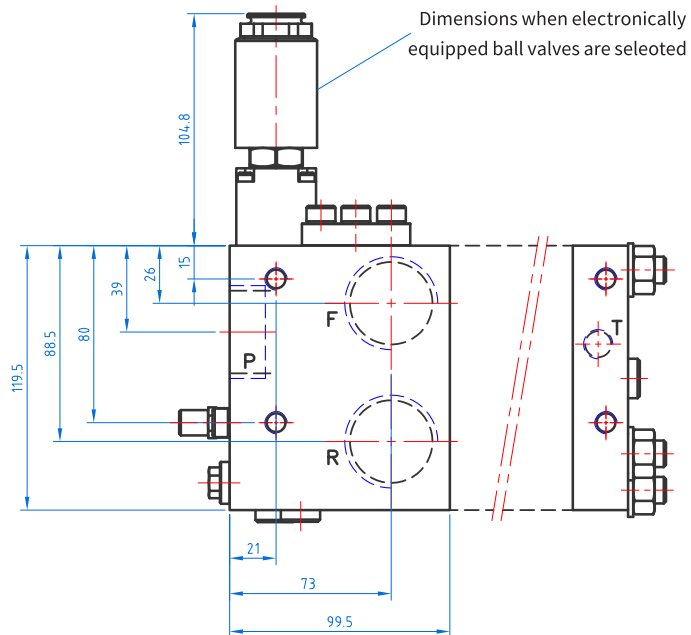



Unit Dimensions

Connection block type TSV 5(6) .../... -5 TSL 5(6). (F,D)/...-5 TSM 6. (F,D)/...-5

Thread standard ISO 228/1 (BSPP):

P,R =G1 1/4 (TSV/L 5..)

=G1 1/4 (TSV/L 6..)

=G1 1/4 (TSM 6..)

M,LS,Z =G1 1/4

DW =G1 1/4 (TSM 6..)

	a	b
TSL 5./., TSL5 ./.	22	75
TSV 6./., TSL 6./., TSM6./.	26	74

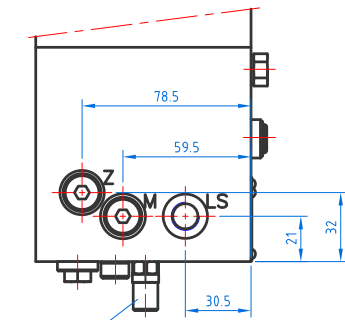

Ls safety Valve
(a/f 12, a/f 13)

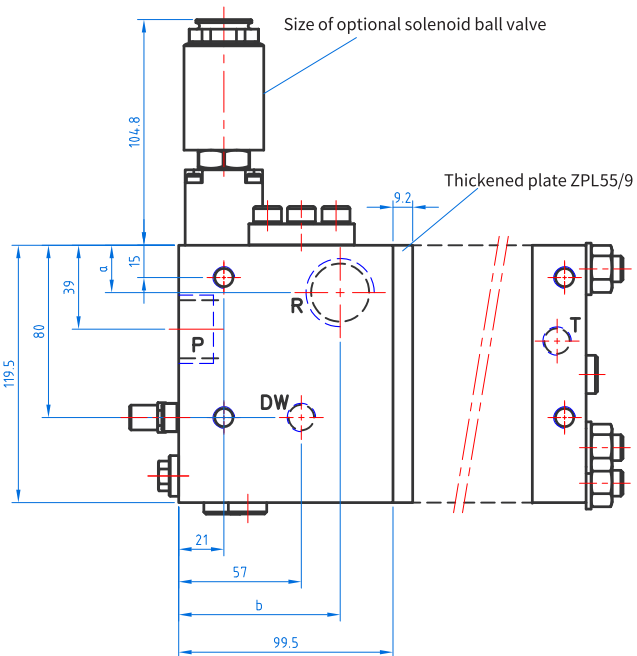
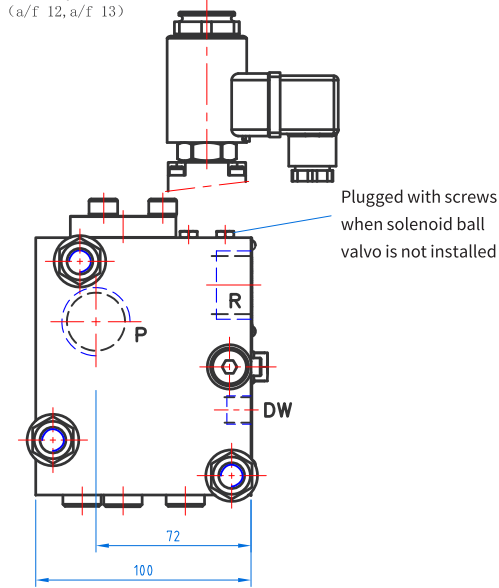

Liquid-controlled directional spool valves
type H,HA,HEA

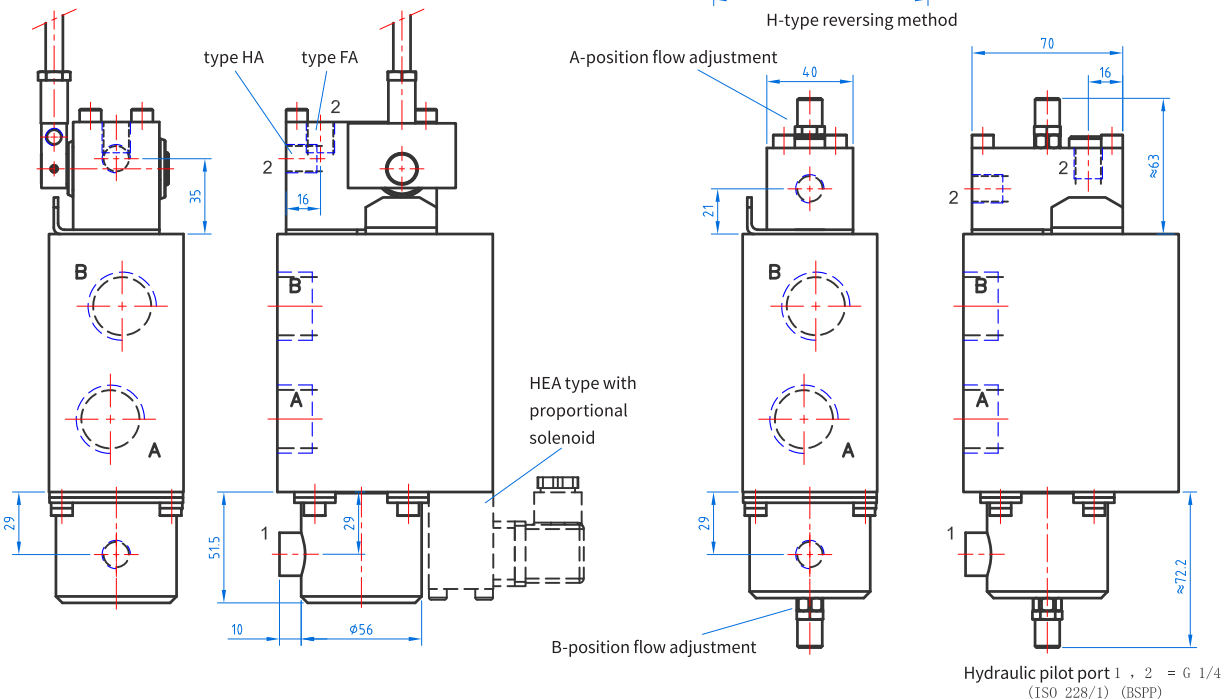

Note: Adjust the limit screw clockwise to reduce the flow, the opposite flow increases. Adjustment screw infinite position, please note that the adjustment screw all screwed out when the oil spray! Recommended Adjustment in neutral position



Unit Dimensions

A, C, D type manual reversing method directional spool valves

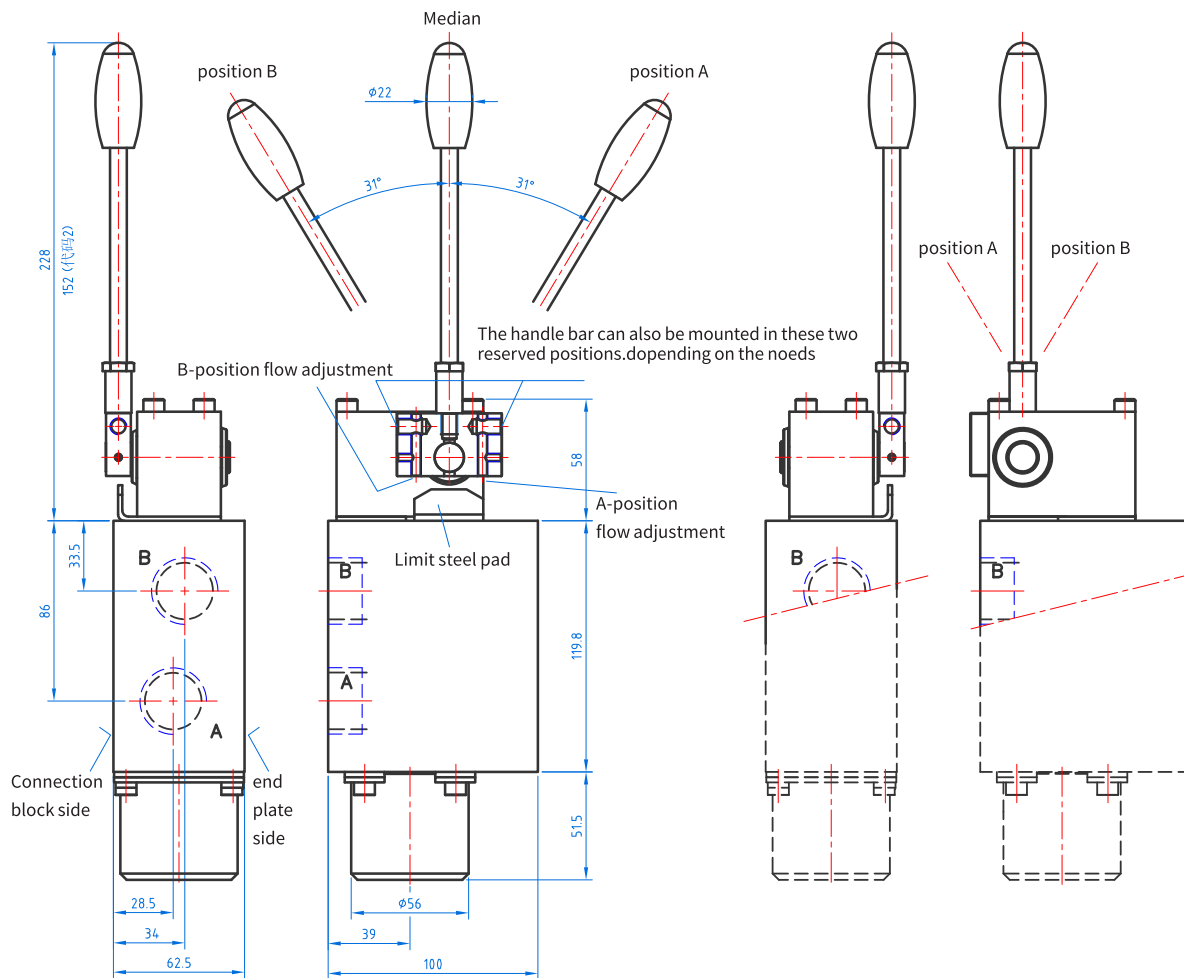

EA,EOA,E type manual operation type directional spool valves external dimensions

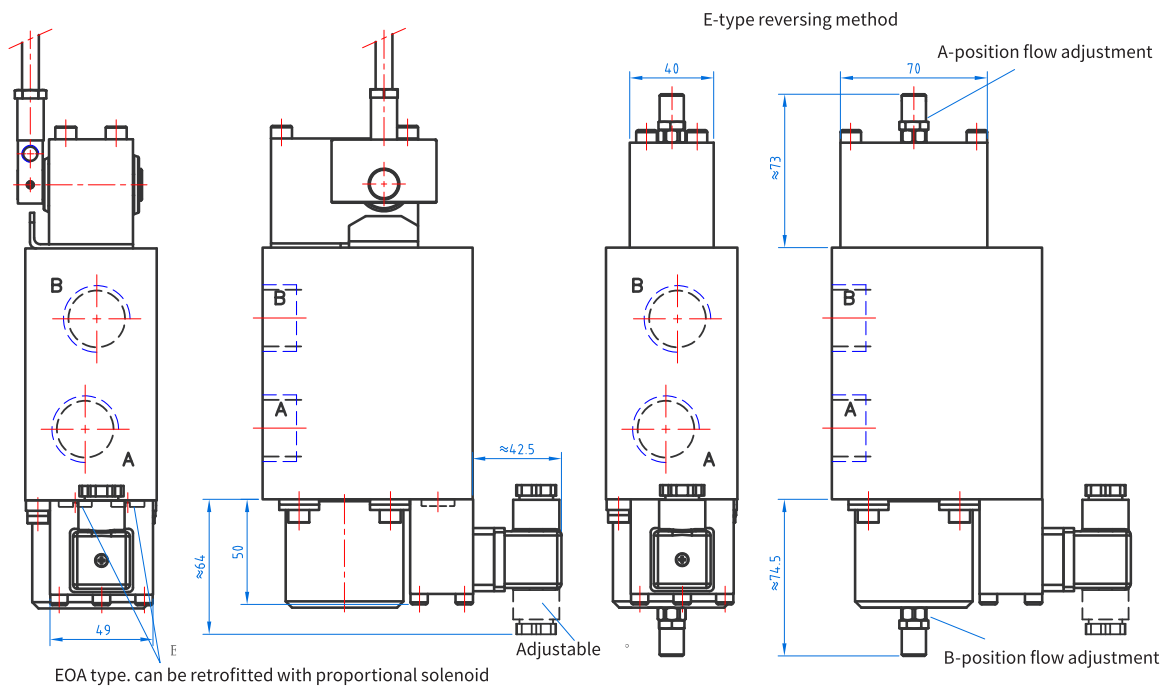



Unit Dimensions

Dimensions of directional spool valves with LS pressure limiting function

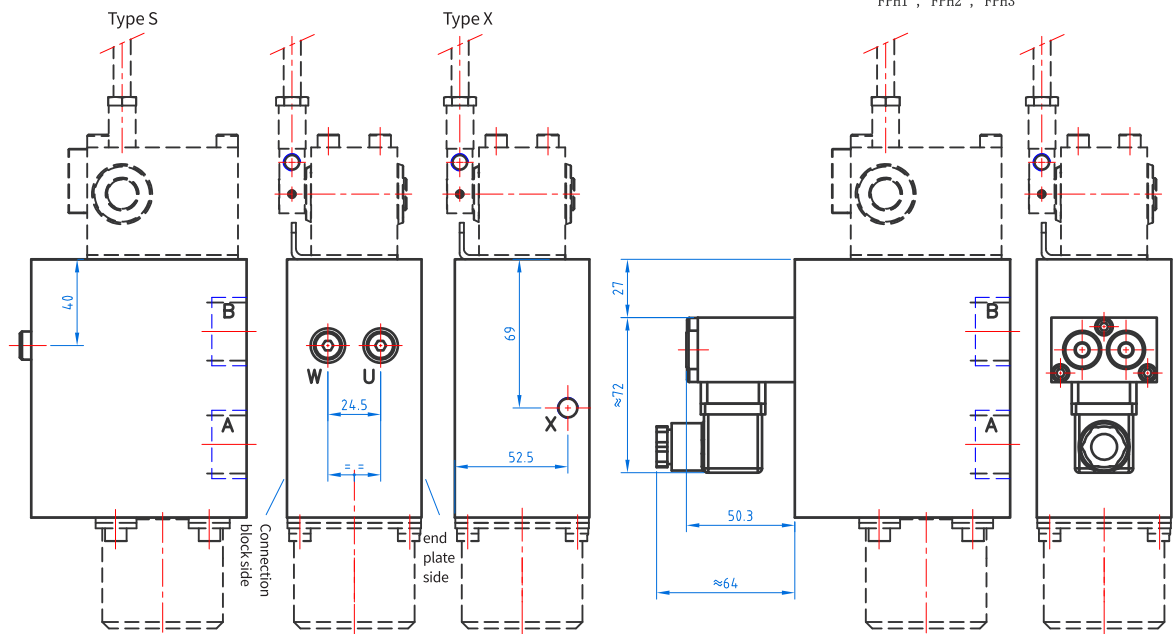
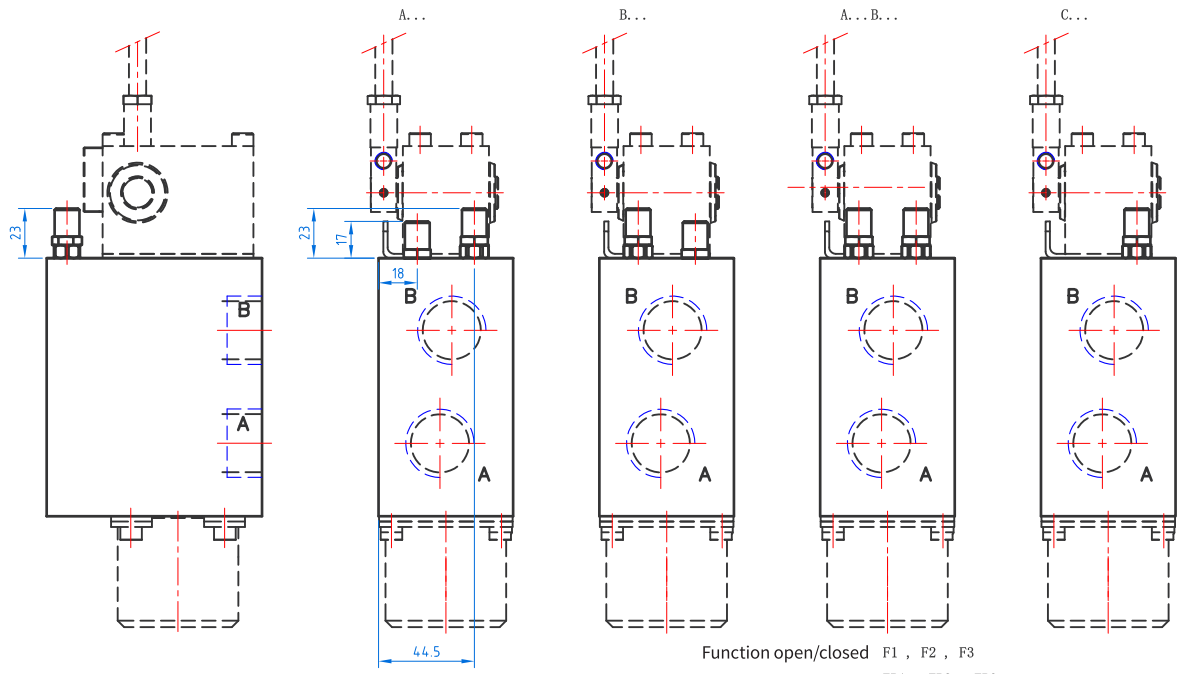

Thread Standard ISO 228/1 (BSPP):

U, W, X = G 1/8



Unit Dimensions

End plate size E1,E2,E4,E5

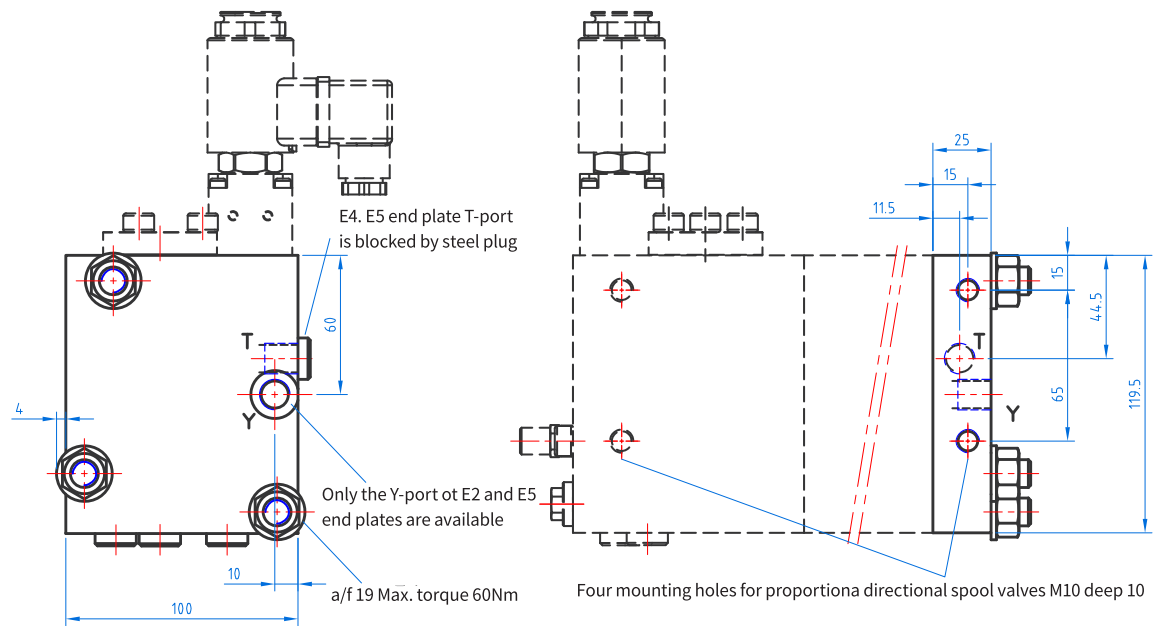

End plate E3,E6

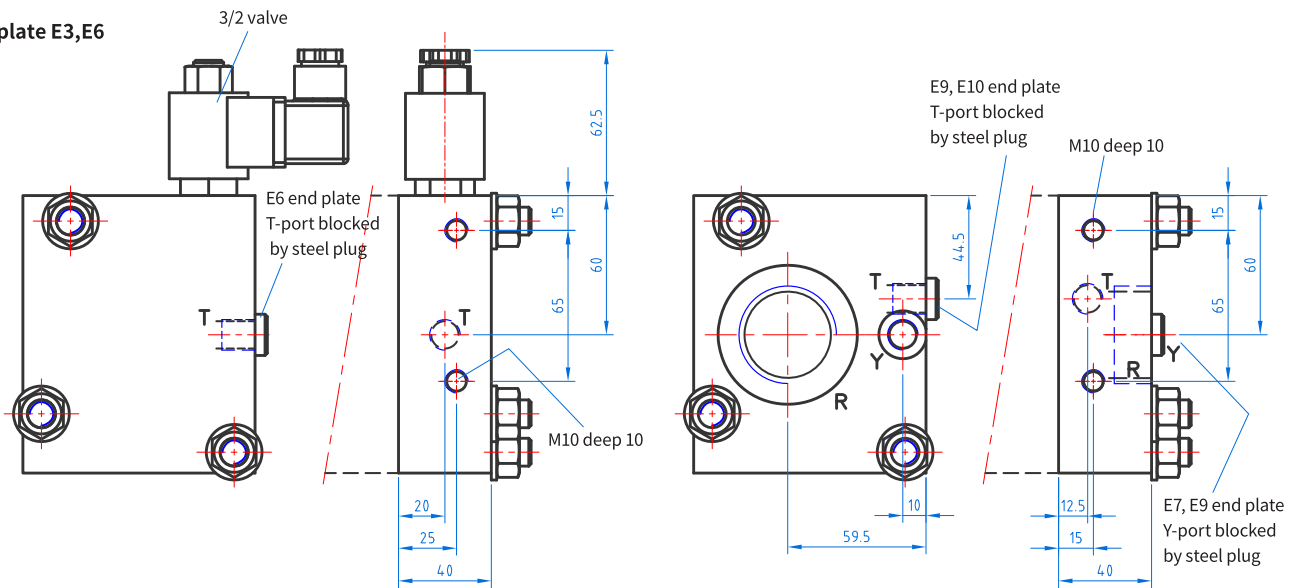

Type E 13 to E16

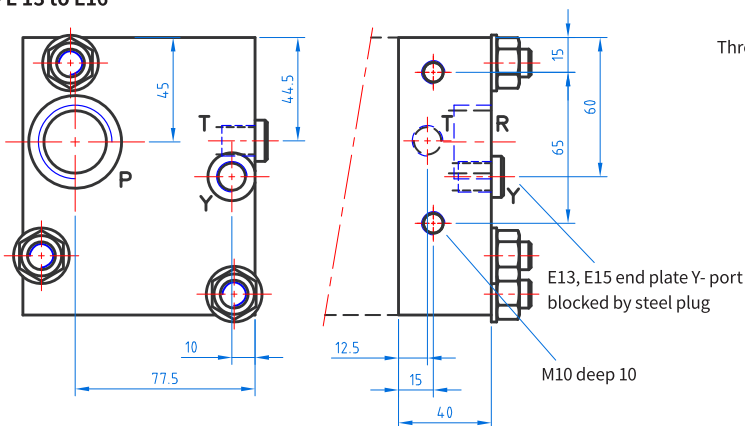

Thread standard ISO 228/1 (BSPP) :

- R = G 1 1/4 (E 7 to E 10)
- P = G 1 (E 13 to E 16)
- T = G 1/4 (E 1 to E 16)
- Y = G 1/4 (E 2 , E 4 to E 16)

TSL/V-CAN

Explosion-proof CAN bus control type & CAN bus control type proportional directional spool valves
Max Pressure 420 bar
Max Flow 240 L/min
Typical Application : Pump trucks, Cranes, Boom Lifts, etc.

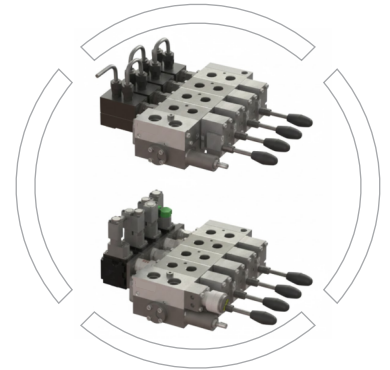

Index

Page No

• Product Overview, Technical Features	60
• Working principle and technical characteristics, Order Code Description	61
• Characteristic Curve	62
• Unit Dimension	63
• Installation, operation, usage instructions	64



Product Overview

CAN bus-control proportional directional spool valve is based on the load-sensing principle. It is a proportional directional spool valve. Each directional valve is integrated with a proportional solenoid, spool position sensor, and digital closed-loop controller, which ensures that the main spool valve moves fast with high-precision position control ability. By presetting an optimized dither signal and a high-performance control algorithm, the output flow of the proportional directional spool valves is more accurate, which helps the operator get excellent control accuracy when controlling the equipment. Therefore, this valve is the best choice for closed-loop or high-precision control applications.

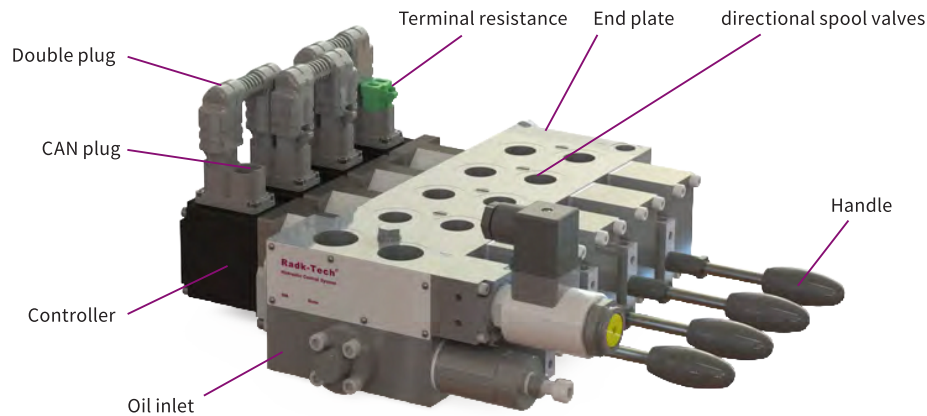

Technical features

1. small dead zone, fast response, easy to achieve closed-loop control of cylinder position
2. Closed-loop control of multi-way valve spool position, with smaller hysteresis and higher repeatability of output flow
3. Simplified wiring, only 4 wires are needed for the whole set of Proportional directional spool valves, power line", CAN-H and CAN-L bus signal lines
4. Each directional valve is equipped with a parallel double DEUTSCH connection socket, which can be connected to the host computer separately
5. Quick connection between valves via double plugs for easy maintenance and repair
6. plug terminal resistor (120 Ω) can be installed in the first or last connection of the Proportional directional spool valve as required
7. with fault diagnosis function, easy to troubleshoot

Hydraulic parameters	
Maximum pressure	420 bar
Flow Range	3 ~ 240 L/min
Displacement hysteresis loop	≤2 %
Flow Deadband	≤3 %
Oil temperature	-40°C ~ +80°C
Electrical parameters	
Supply voltage	12 ~ 30 VDC
Communication protocols	CAN open
Baud rate	50, 100, 125, 500 · 1000 kbit/s
Valve ID number	1...127
Command signal	+100 Equivalent to :100 of the signal
Connection socket	DT06-4P Mating plug typeDT06-4S
Pin Definition	1-CAN-H.2-CAN-L3-Power supply positive terminal · 4-Power negative/ground
Protection level	Ip67



Working principle and technical characteristics

CAN bus proportional directional spool valves contains connection block, directional spool valves, end plate and electronic control module (digital controller + proportional solenoid). The 4 pins of the connection plug receive 12-30VDC power supply, when the 1,2 pins receive the command signal in accordance with the CAN bus protocol format, the CAN bus interface will convert the signal into the command signal corresponding to the main spool position, the main spool of the directional spool valves is equipped with a position sensor, which can detect the spool position feedback in real time and convert it into a corresponding voltage signal to the digital signal processor, the error of the command signal and the actual position signal is delivered to the current signal amplifier after the PID algorithm, and the amplifier outputs the PWM current signal with the dither signal to the proportional solenoid, then the pilot proportional valve open, and the pilot oil pushes the main spool to move, when the position of the main spool is the same as the command signal, the spool stops moving until the command signal changes. So the Flow is proportional to the command value.

Note: Do not give the command signal to the proportional directional spool valves without oil supply, avoid electronics damage.

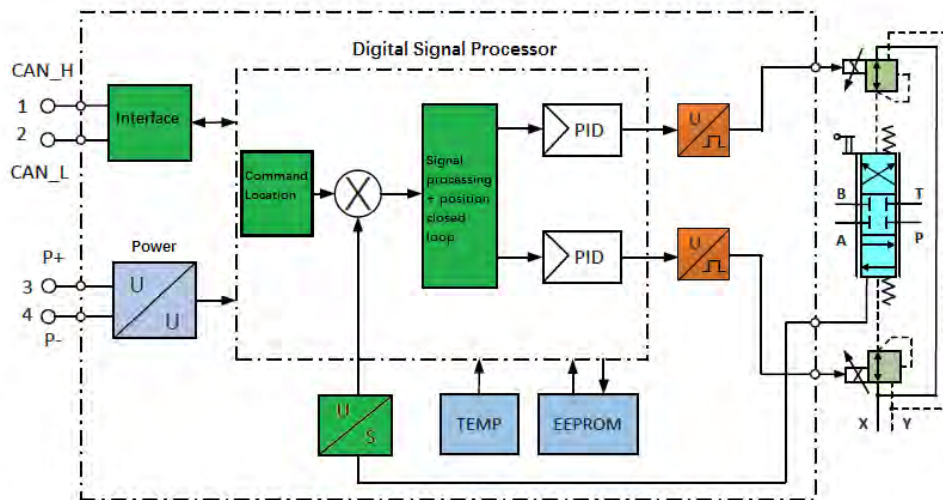

Order Code Description

TSL 4.1F/370-3

-32 H 80/63 /EA-CAN-C

-32L 63/40/EA-CAN

-32C 25/16/EA-CAN-T

-E1-DT-0-CANopen/250/G24

- C: proportional directional spool valve CAN socket on the first piece of valve
- T: with terminating resistor plug ,on the last valve piece

Supply voltage ,12-32 VDC

Baud rate selectable :50,100,125,500,1000kbits

communication protocols, CAN open

DT: connection socket, DT04-4P

MSHA-10: Coal mine safety explosion-proof type, wire lenth10m

Please refer to the TS-2,3,5 size proportional directional spool valve catalog for model number other than those in bold above.



Characteristic Curve

The following curve shows the control accuracy of a 10 L/min spool valve. When signal is 0...+1000, Port A work, and signal 0...-1000, Port B work.

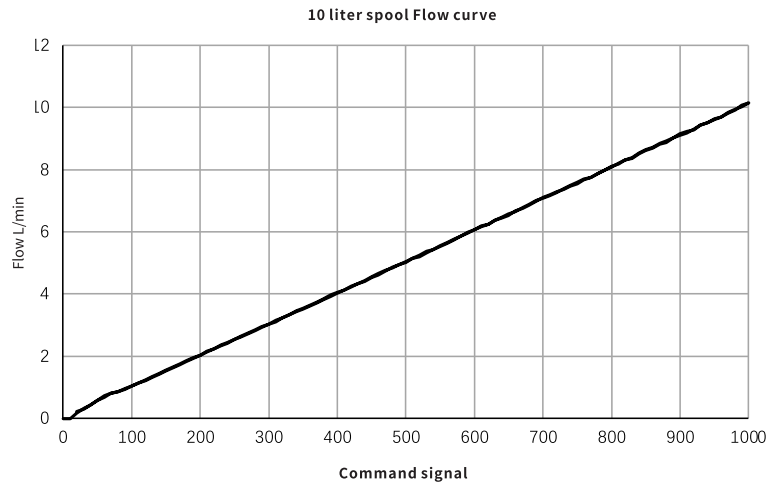

Unit Dimensions

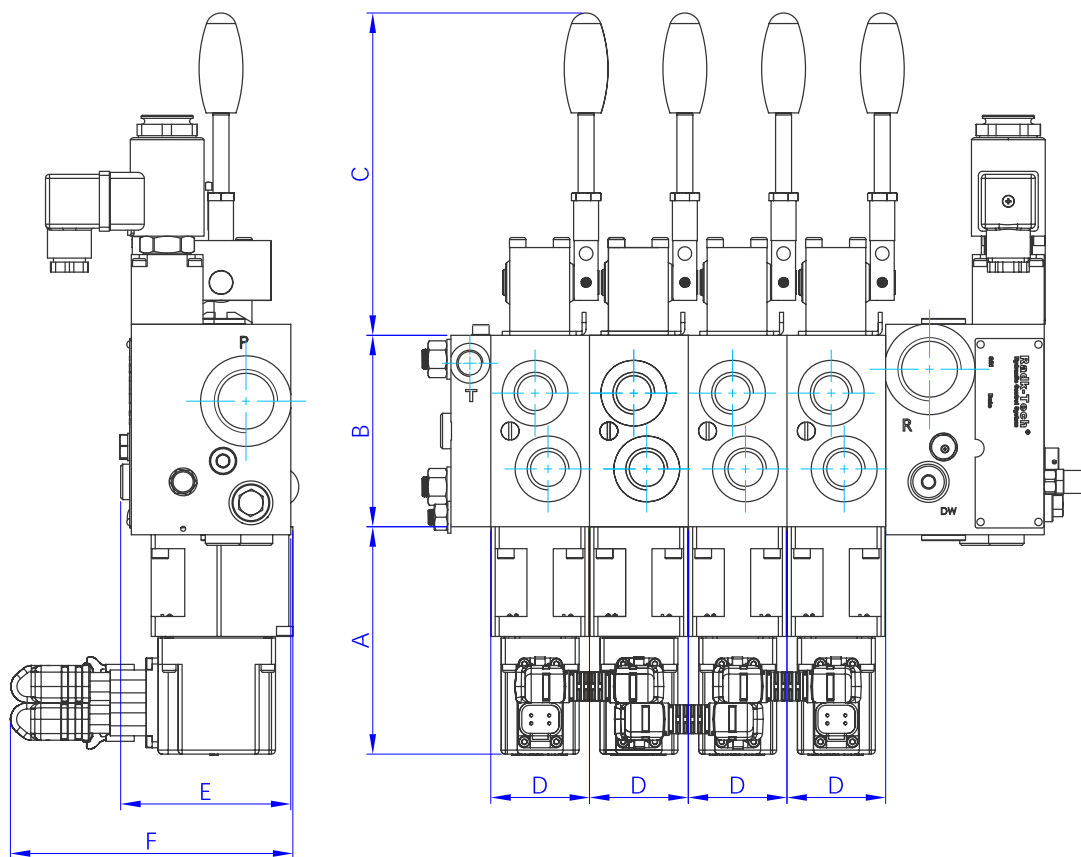

	A	B	C	D	E	F
Size 2	104	79.5	157	39.5	75	139
Size 3	114	96	148-228	49.5	86	142
Size 5	18.5	119.5	152-228	62.5	100	152

The above dimensions are the basic dimensions for reference, you can the detailed 2D and 3D drawings from the sales department.



Unit Dimensions

Explosion-proof CAN bus control proportional directional spool valves.

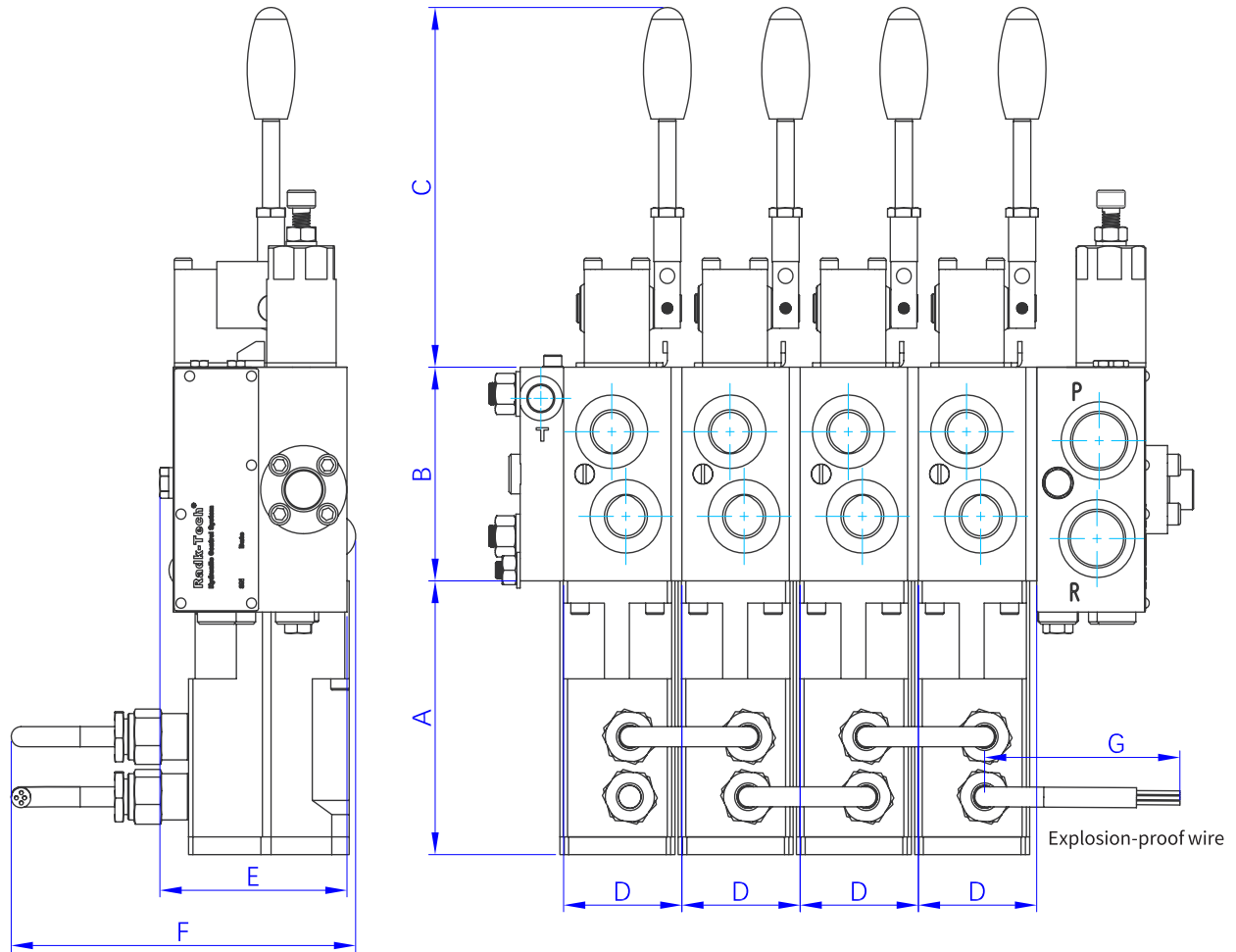

	A	B	C	D	E	F	G
Size 3	125	96	148-228	54.5	86	150	As requested by order
Size 5	135	119.5	152-228	62.5	100	160	As requested by order



Installation, operation, usage instructions

- Make sure the oil port is connected correctly, especially note that P and R cannot be reversed, and the T port is connected to the oil tank to ensure that there is no back pressure back to the oil .
- Do not pull or squeeze the connection plugs and wires on the CAN bus controller, otherwise it will lead to poor contact or damage;
- It is recommended to use three bolts to mount the valve on the equipment, and use a resilient gasket between the mounting surface of the valve and the equipment mounting plate to prevent the valve from jamming or seepage due to uneven bottom surface and excessive mounting torque that can cause microscopic deformation of the proportional directional spool valves from twisting forces;
- The electromagnetic compatibility of the equipment system is guaranteed by the system manufacturer;
- Proportional directional spool valve should be installed away from the engine or exhaust device near a large amount of heat to avoid high temperature damage;
- Maintain a distance of more than 0.5m from the magnetic field source
- The user must not disassemble the product without training or instruction, and any damage caused by this is not covered by the warranty;
- Oil temperature range -40~80°C, beyond the range will make the seal damaged by aging, resulting in oil seepage or oil leakage;
- Keep hydraulic fluid clean according to ISO 20/18/15, contamination may cause spool sticking or jamming, or even irreparable part damage
- Make sure that the valve works under the maximum safety pressure.
- The CAN bus connection cable is a twisted-pair cable with a wave impedance of 108 to 1320 in accordance with ISO11898-2
- The data transmission format is the CAN-open 2.0 A&B protocol based on 11-bit address data;
- The maximum current of each valve is about 1.5A when 12V is supplied, and about 0.8A when 24V is supplied;
- In general, the linear network topology should be implemented as far as possible to avoid short cut-off lines, if this is not possible, the maximum length of short cut-off lines is implemented in accordance with the following table;

Transmission rate	CAN line length	Maximum short cut length
100 Kbit/s	600 m	25 m
125 Kbit/s	500 m	20 m
250 Kbit/s	250 m	10 m
500 Kbit/s	100 m	5 m
1000 Kbit/s	≤20 m	1 m

TS-VB0124

Electronically controlled Proportional directional spool valves
 Maximum pressure:150bar
 Maximum flow rate:30L/min
 Typical application: Agricultural machinery

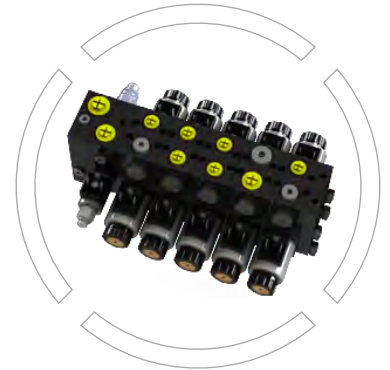

Index

Page No

- | | |
|---|----|
| • Product Overview, Working principle and technical characteristics | 65 |
| • Technical parameters, Unit Dimension | 66 |

Product Overview

Vb00124 is a five block Proportional directional spool valves. It is a unified modular design, which can provide a reliable system solution for agricultural machines. The user can combine the valve body according to the functional requirements, which is simple and reliable. This five block Proportional directional spool valves consists of an oil inlet link, five working links and a tail link. The inlet link is a solenoid relief valve, which is used for over-limit protection of the working mechanism. When the solenoid valve is in the middle position, the hydraulic lock can prevent the mechanism from sinking.

Working principle and technical characteristics

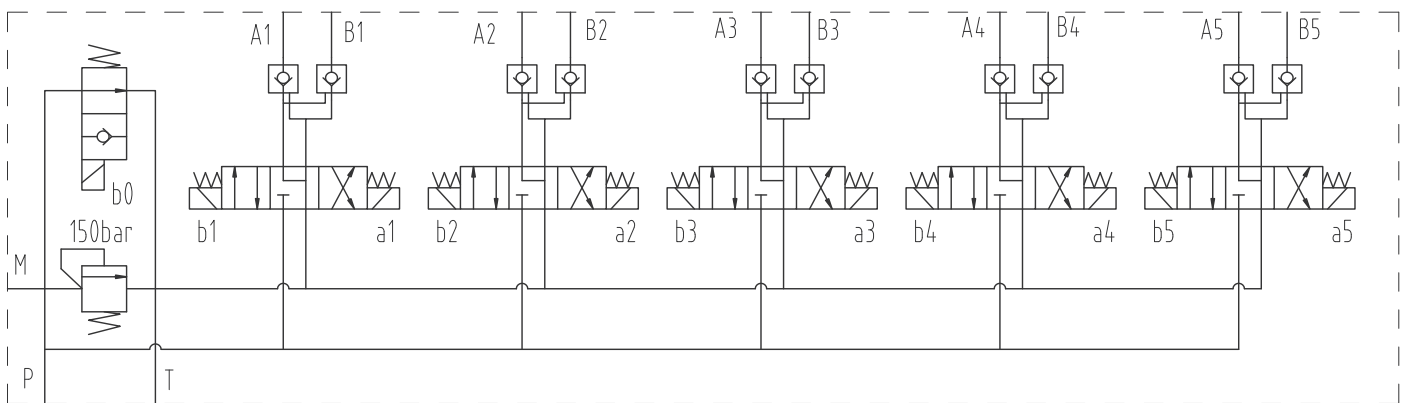



Technical parameters

Hydraulic parameters	
Working pressure	150bar
Testing pressure	210bar
Max. flow	30L/min
Operating ambient temperature	-20-50°C
Operating oil temperature	-20-90°C
Electrical parameters	
Solenoid voltage	DC24V±15%
Electromagnetic coil waterproof grade	IP 65
Solenoid power	30W

Unit Dimensions

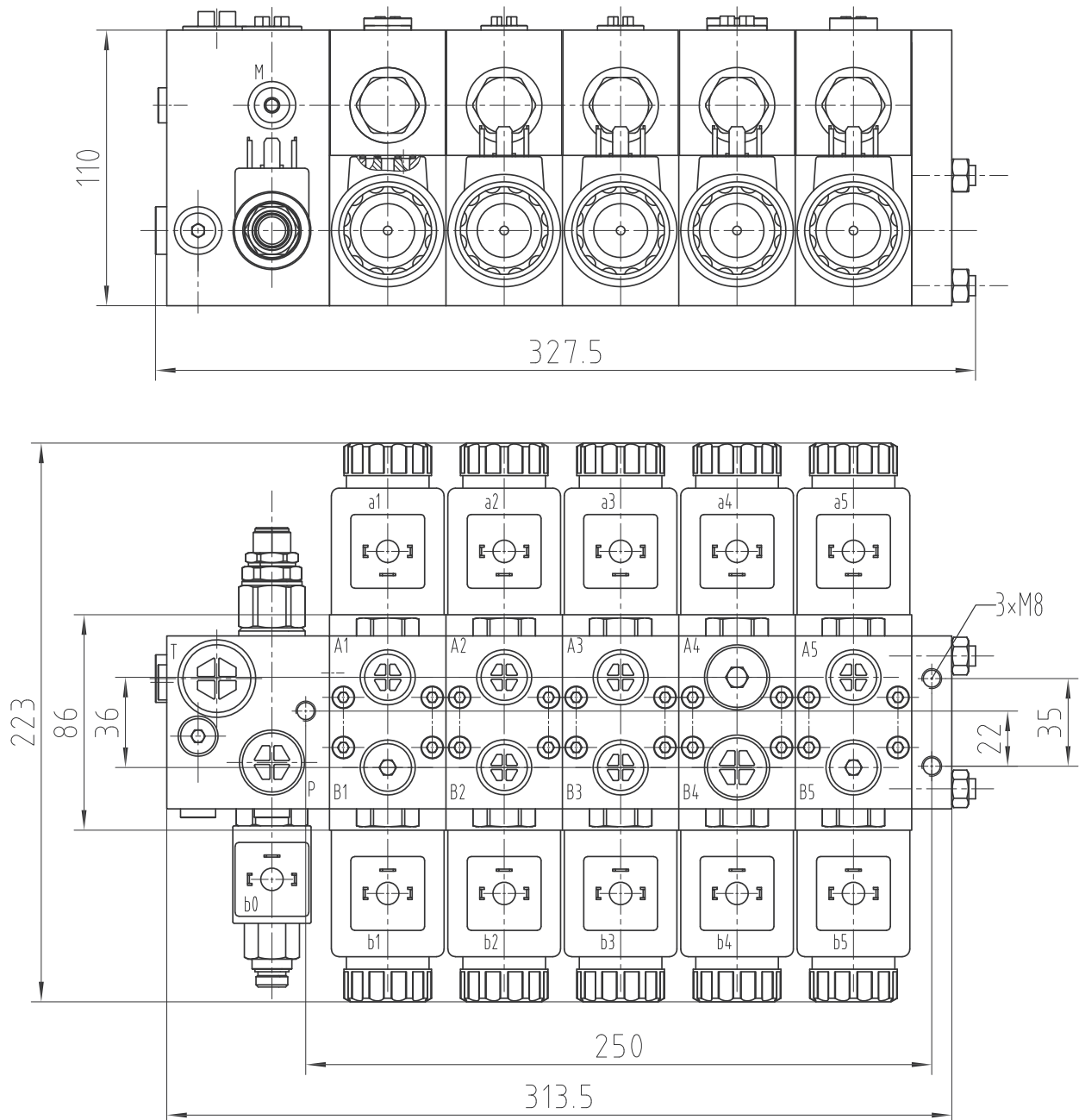

PA222

Proportional amplifier

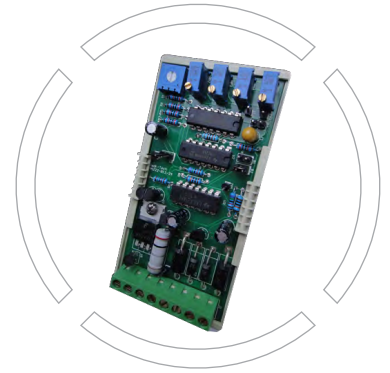

Index

Page No

• Product Overview, Electrical characteristics parameters	68
• Amplifier principle, Amplifier adjustment and wiring	69
• Amplifier External Dimensions ,Installation and commissioning	70
• Installation and commissioning	71



Product Overview

The PA222 series amplifiers are used with the TS size II, III, and V Proportional directional spool valves · proportional solenoids and other applicable proportional valves. The amplifier converts the input control signal into a corresponding current signal:

PA222-812/24 Voltage range: 12 - 24 VDC

PA222-824/48 supply voltage range: 24-48 VDC

Main components: voltage controller, linear ramp generator, chattering signal generator

Product features

1>The maximum current I max and the minimum current I min can be output by multi-turn potentiometer

2>Dither signal amplitude adjustable, dither frequency optional 60Hz or 120Hz

3>With power supply reverse polarity protection function

4>The rise and fall time of the section ramp is adjustable

5>With 8 bolt-type terminal block, easy wiring

6>Connecting wire up to 1.5 square mm

7>Clamped on 35 or 32 mm standard bracket rail via DIN EU6075

8>Using ambient temperature -20°C- +50°C

Electrical characteristics parameters

Supply voltage	PA222-812/24 (9- 32VDC) PA222-824/48 (18- 65 VDC)
Current regulation	PA222-812/24 max. output current 2.4A (min. current adjustment: 0- 1.6, max. current adjustment: min. current - 2.4A) PA222-824/48 max. output current 1.5A (min. current adjustment: 0- 1.5, max. current adjustment: min. current - 1.5A)
Output Voltage	Input voltage - 1.2 VDC pulse width modulation
Output Current	Max. 2.4 A, short-circuit protected
Chattering frequency	60Hz or 120Hz, factory default setting is 60Hz
Dither amplitude	0- 750 mA (peak to peak)
No-load current	20 mA max.
Input voltage	0-5VDC; 0-10VDC; 0-15VDC; factory preset 0-5 VDC
Base voltage	5VDC 4% carrying capacity max. 5 mA (steady state voltage, for potentiometer setpoint)
Input resistance	>200 K Ω
Set value potentiometer	2K Ω -10K Ω
Ramp time lift	0.1-10S. Adjustable rise and fall time, factory preset to a minimum value of 0.1S
Unlocked closed loop input	TTL compatible or can be turned on to disable the output
Ripple coefficient	< 10%



Amplifier principle

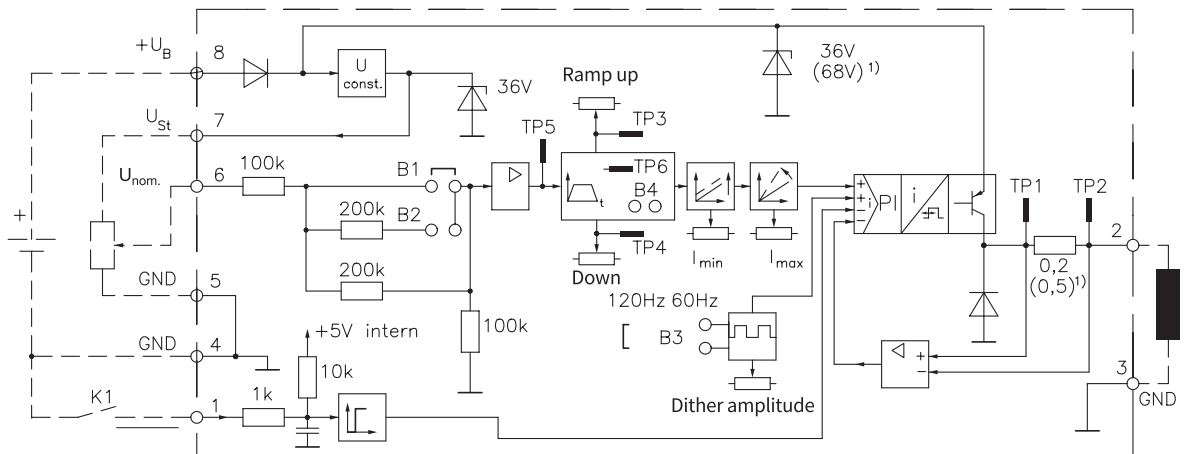

Amplifier adjustment and wiring

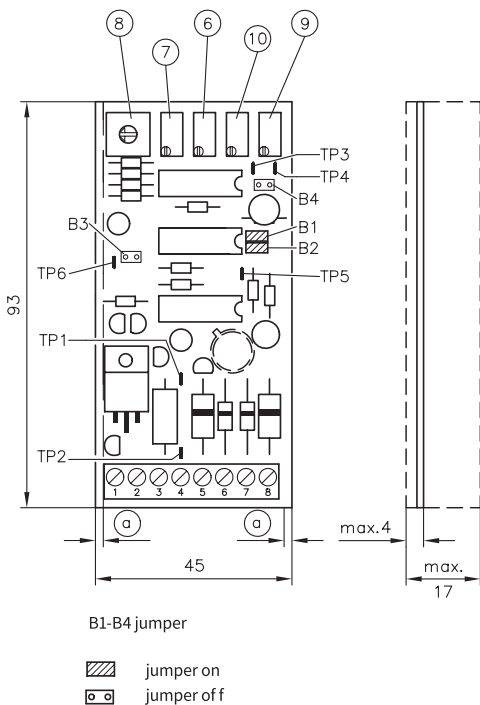

Potentiometer adjustment direction \nearrow \searrow
- +

- ⑥ Potentiometer : Ramp down time t_{down} (Adjustable 25 turns)
- ⑦ Potentiometer : Ramp up time t_{up} (Adjustable 25 turns)
- ⑧ Potentiometer : Dither amplitude (Adjustable 25 turns)
- ⑨ Potentiometer : Minimum regulation current (Adjustable 25 turns)
- ⑩ Potentiometer : Maximum regulation current (Adjustable 25 turns)

- TP1 Test point 1+ for current measurement
- TP2 Test point 2- for current measurement
- TP3 Test point 3, to adjust the ramp up
- TP4 Test point 4, adjust ramp down
- TP56 Test point for ramp time adjustment

Terminal assignment

- 1 - Enable/Disable input
- 2- + Solenoid
- 3- 0V solenoid ground
- 4- 0V output, power ground
- 5- 0V limit ground
- 6- Setpoint input
- 7- Reference voltage $U_{st} (+5VDC)$
- 8- Power supply voltage $+U_B$

Set point voltage range 0- 5 VDC when B 1, B2 are on simultaneously
 Set point voltage range 0 - 10 VDC when B1 is off and B2 is on
 B3 - for dither frequency adjustment
 Dither frequency 120 Hz when B3 is on, 60 Hz when it is off
 B4 on for ramp time adjustment only, otherwise B4 stays on



Amplifier External Dimensions

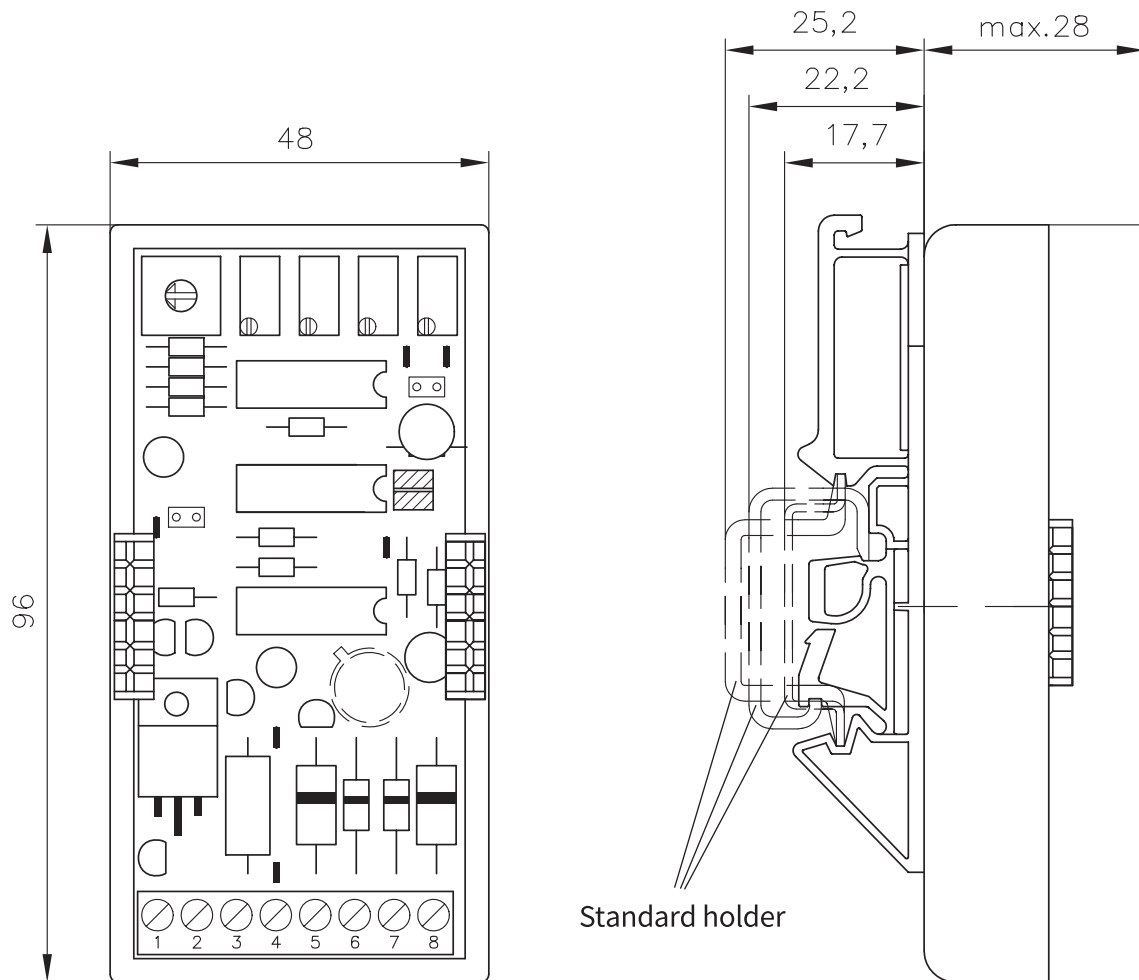

Installation and commissioning

Refer to the picture on the right

- 1>If the rated voltage range is 5V, then its internal reference voltage $U_{st}=5V$ when applied
- 2>Bridge state, factory preset B1, B2 on, other are off, user can adjust according to the use of the situation
- 3>The rated voltage of external input is not allowed to be negative, the negative voltage will cause the amplifier to malfunction and destroy the amplifier. When the maximum rated voltage exceeds 5, 10 or 15V, the minimum and maximum currents will not work, i.e. it exceeds the limit value of the adjustment.
- 4>In the wire length of more than 3m, should use a double twisted together cable, to reduce the emission of interference, improve the ability to resist interference
- 5>The maximum coil current I_{max} adjusted at the output port should not exceed the minimum current value given by the proportional solenoid for a long time, otherwise the solenoid overheats and is prone to failure.

F1 = Fuse 2.5 AmT (PA222-812/24)

=Fuse 1.6 AmT (PA222-824/48)

V1 = Voltmeter, for detecting coil current $100\text{ mV}=0.5A$ (PA222-812/24)

=Voltmeter for detecting coil current $100\text{ mV}=0.2A$ (Pa222- 824/48)

TP1 = Test point 1

TP2 = test point 2

P1 = Setpoint potentiometer 2- 10 K Ω



Installation and commissioning

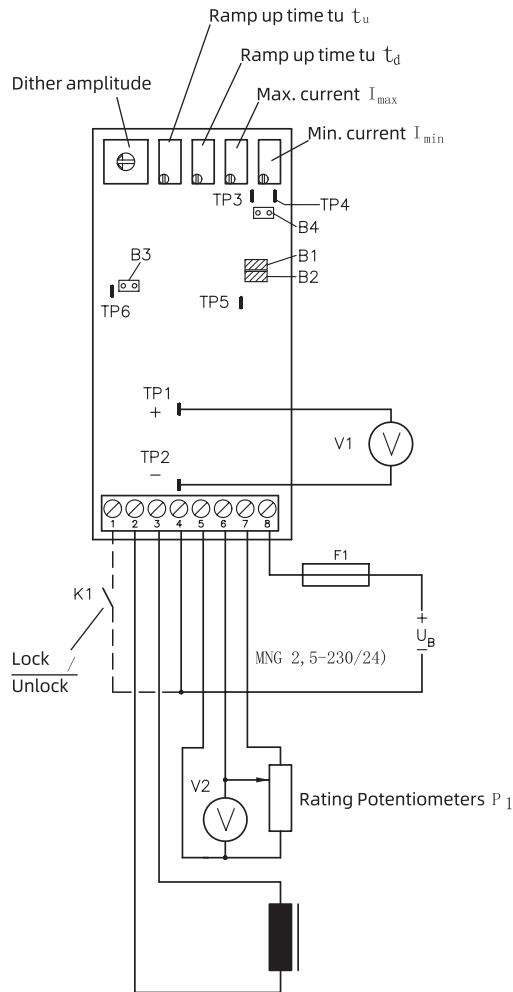

With double-action solenoid or two separate action solenoid wiring diagram

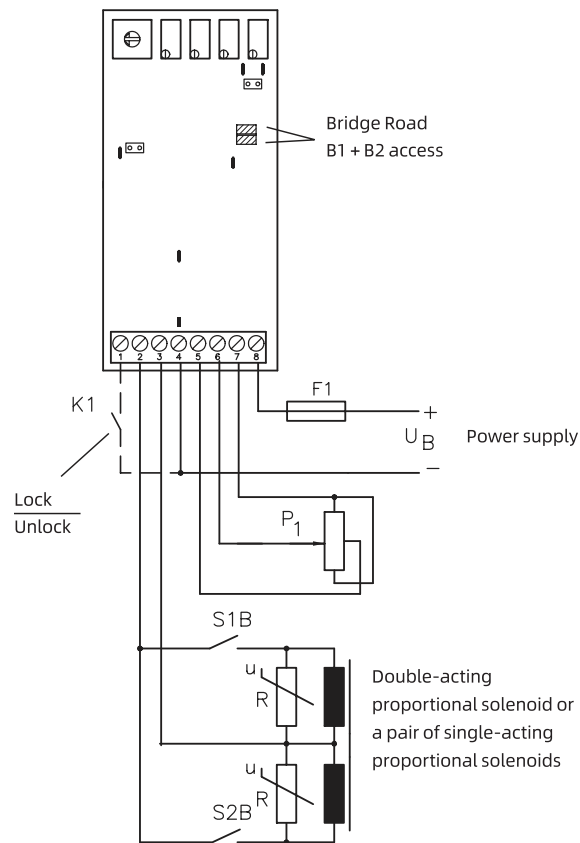

There must be a potentiometer with intermediate tap and two reversing switches SB1, SB2 for controlling two solenoid coils respectively, such as two, three, five size Proportional directional spool valves

P1: Potentiometer, 2X5 KΩ

R: 31V variable resistor

SB1, SB2: Electric control handle integrated

Ramp time quick adjustment method

Generally, the ramp time is determined by debugging, which is a simple but time consuming method. The relationship between the ramp time and the full rotation of the trimmer potentiometer (25 turns) is not current. The ramp time can be adjusted using the following curve and a digital meter with approximately 15% accuracy (input impedance of at least 100K) in the following way

- 1> Jumper B4 on, terminals 4 and 8 connected to the power
- 2> Adjust the adjustment ramp. Up time
TP5 is connected to terminal 7 (5V), connect the voltmeter between TP6 and TP3, get the voltage value from the curve according to the desired ramp time, and adjust the ramp time potentiometer according to the voltage value.
- 3> Adjust the ramp down time
TP5 terminal 5 (0V) is connected to the voltmeter between TP6 and TP4, the voltage value is obtained from the curve according to the desired ramp time, and the potentiometer of the ramp time is adjusted according to the voltage value.

4> Disconnect jumper B4

Note: The proportional amplifier cannot operate when B4 is on.

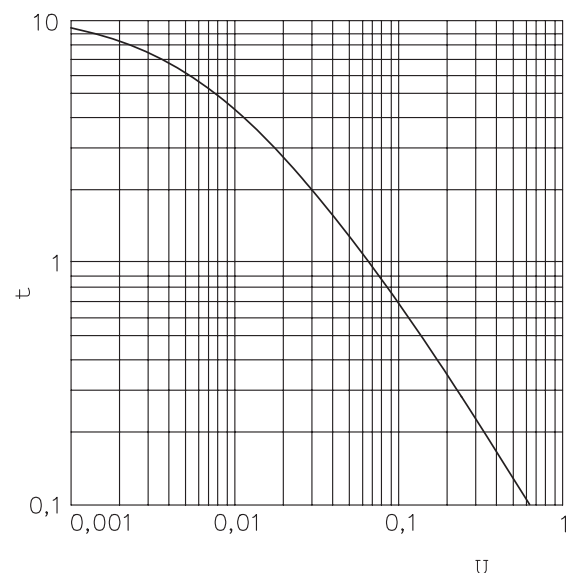



LUDHIANA HEAD OFFICE:

F-127, PHASE-VIII,
FOCAL POINT
LUDHIANA - 141010
(PUNJAB) INDIA

DELHI BRANCH OFFICE:

C-140, PHASE-II,
MAYAPURI,
NEW DELHI - 110064
INDIA

AHMEDABAD BRANCH OFFICE:

#23, RATNAM INDUSTRIAL
ESTATE, KATHWADA DASKROI,
AHMEDABAD - 382430
GUJARAT, INDIA



THM
HYDRAULICS

THM HUADE HYDRAULICS (P) LTD

PHONE: +91 88722-42200, +91 88722-41800, +91 88722-42500

E-mail: salesho@thmhuade.com, varun@thmhuade.com

Website: www.thmhuade.com